

Adjustable End Stop

ME-8971

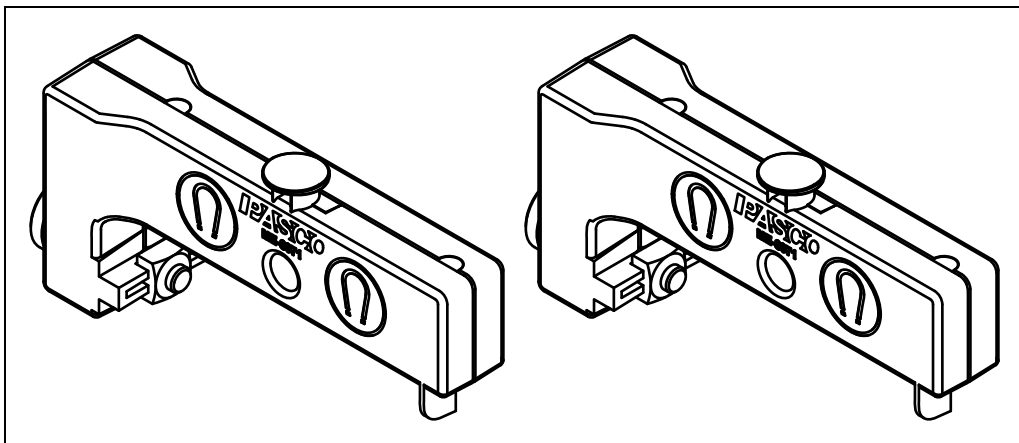

Introduction

PASCO model ME-8971 is a set of two end stops for use with PASCO tracks and carts. It is compatible with any aluminum or plastic PASCO track and with any PASCO cart such as the Plunger Cart or Smart Cart. See the PASCO catalog or the PASCO web site at

www.pasco.com

for information about other accessories such as springs, bumpers, pulleys, masses, and special attachments that are designed to be used with PASCO tracks and carts.

Installation

Attach each end stop to the T-slot on the side of the tracks as illustrated. Slide the end stop to any position along the track and secure it by tightening the thumbscrew.

One side of the end stop contains magnets to repel the magnetic bumper of a cart. The stud on top of the end stop

can be used for attaching a spring or string. The Hole is designed to be used with a Spring Cart Launcher (PASCO model ME-6843).

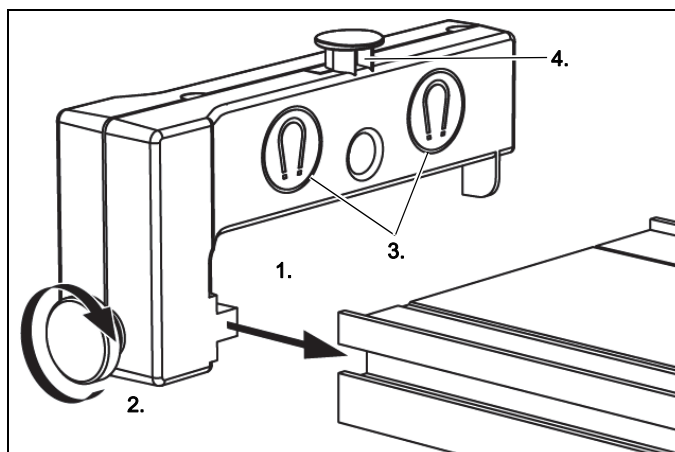

1: Slide tab into T-slot on side of track. 2: Tighten thumbscrew to secure end stop. 3: Magnets repel cart's magnetic bumper. 4: Spring attachment stud

For Use with Older Tracks

If you have an older PASCO track (see illustration), install the included washers to prevent the thumbscrews from “bottoming out.”

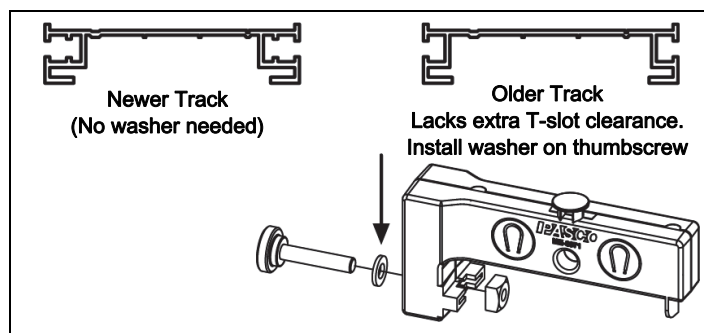

Cart and Track Dynamics Systems

Adjustable End Stops are included in bundles with tracks, carts, adjustable feet, a track pivot clamp, a friction block, and other accessories such as mass bars, springs, photogate brackets, “cart picket fences”, and a pulley with clamp.



For information about the suggested equipment and other items for use with the Adjustable End Stop, see the PASCO catalog or the PASCO web site at

www.pasco.com

Technical Support

For assistance with any PASCO product, contact PASCO at:

Address: PASCO scientific
10101 Foothills Blvd.
Roseville, CA 95747-7100

Phone: 916-462-8384 (worldwide)
800-772-8700 (U.S.)

Web: www.pasco.com

Email: support@pasco.com

More Information

For more information about the latest revision of this Instruction Manual, visit:

www.pasco.com/manuals

and enter the Product Number.

For information about any PASCO product, what software to use, and what other accessories are available, check the PASCO web site.

Warranty, Copyright, and Trademarks

Limited Warranty For a description of the product warranty, see the PASCO catalog. **Copyright** The PASCO scientific 012-09992B *Instruction Manual* is copyrighted with all rights reserved. Permission is granted to non-profit educational institutions for reproduction of any part of this manual, providing the reproductions are used only in their laboratories and classrooms, and are not sold for profit. Reproduction under any other circumstances, without the written consent of PASCO scientific, is prohibited. **Trademarks** PASCO and PASCO scientific are trademarks or registered trademarks of PASCO scientific, in the United States and/or in other countries. All other brands, products, or service names are or may be trademarks or service marks of, and are used to identify, products or services of, their respective owners. For more information visit www.pasco.com/legal.

Angle Indicator

ME-9495A

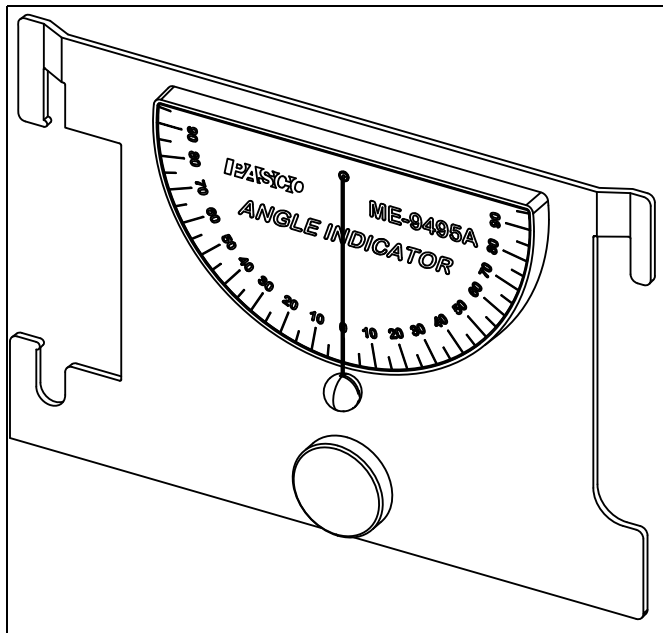

- attached to a PASCO Cart by sliding the device into the slots on the top of the cart.

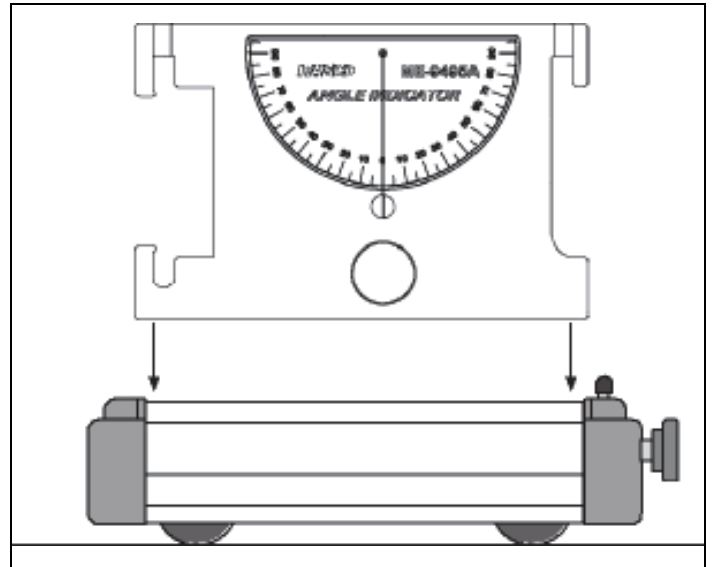

- attached to the side of a PASCO Track.

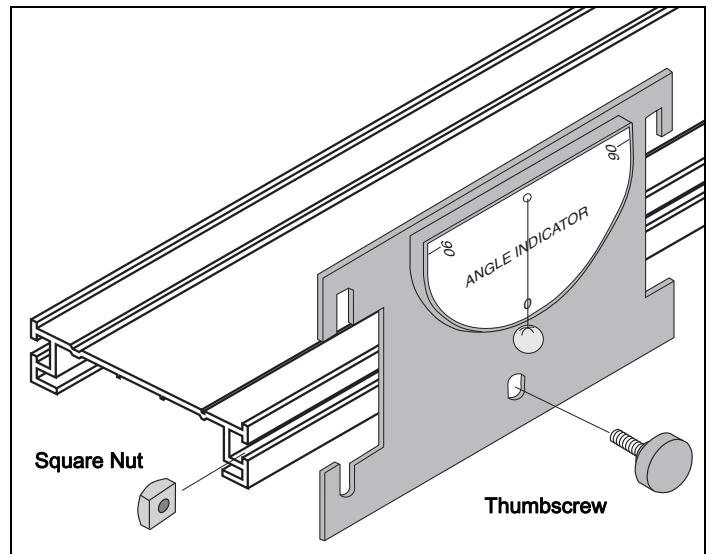

Introduction

The PASCO ME-9495A Angle Indicator is an accessory used for measuring angles from 0° to 90° in two directions. There are four different methods of using the Angle Indicator:

- hand-held, by suspending the device over a string.

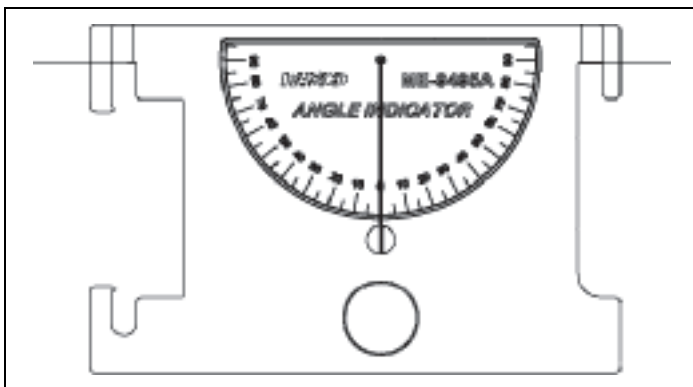

- slipped over the platform on the PASCO Rotary Motion Sensor.

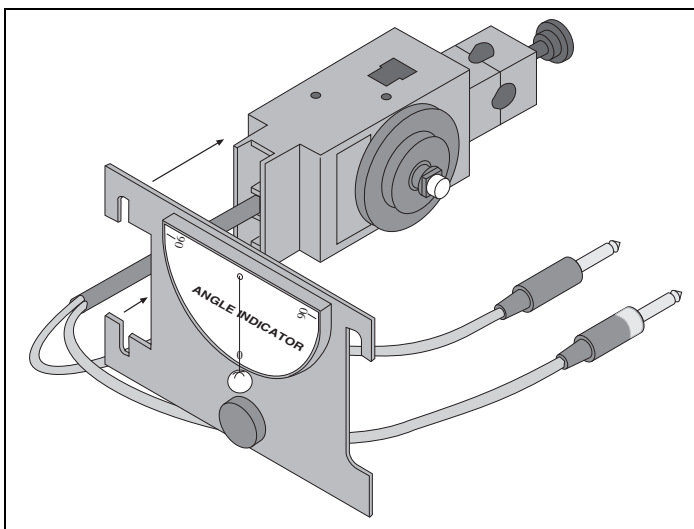

Maintenance

The thread that supports the spherical weight is attached to the back of the Angle Indicator with a hex screw.

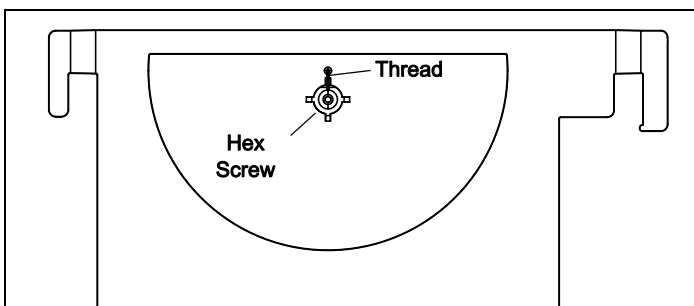

Loosen the hex screw in order to replace the thread.

Technical Support

For assistance with any PASCO product, contact PASCO at:

Address: PASCO scientific
 10101 Foothills Blvd.
 Roseville, CA 95747-7100

Phone: 916-462-8384 (worldwide)
 800-772-8700 (U.S.)

Web: www.pasco.com

Email: support@pasco.com

Replacement Parts

Check with Technical Support about possible replacement parts:

Item	
Brass weight	Hex screw
Thumbscrew	Nylon thread
Square nut	

More Information

For more information about the latest revision of this Instruction Manual, visit:

www.pasco.com/manuals

and enter the Product Number.

For information about any PASCO product, what software to use, and what other accessories are available, check the PASCO web site.

Warranty, Copyright, and Trademarks

Limited Warranty For a description of the product warranty, see the PASCO catalog. **Copyright** The PASCO scientific 012-10860C *Instruction Manual* is copyrighted with all rights reserved. Permission is granted to non-profit educational institutions for reproduction of any part of this manual, providing the reproductions are used only in their laboratories and classrooms, and are not sold for profit. Reproduction under any other circumstances, without the written consent of PASCO scientific, is prohibited. **Trademarks** PASCO and PASCO scientific are trademarks or registered trademarks of PASCO scientific, in the United States and/or in other countries. All other brands, products, or service names are or may be trademarks or service marks of, and are used to identify, products or services of, their respective owners. For more information visit www.pasco.com/legal.

Bumper Accessory Set

ME-9884

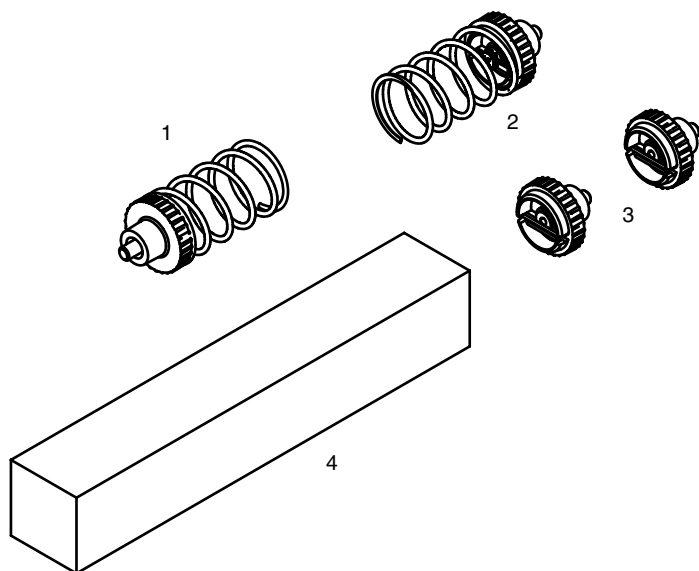

Included Equipment

1. Light Spring Bumper
2. Heavy Spring Bumper
3. Clay Holders (2 pieces)
4. Clay

Additional Equipment Recommended

	Part Number
Force Sensor	CI-6537, CI-6746, or PS-2104
Cart	ME-6950, ME-6951, ME-9430, or ME-9454

Introduction

The Bumper Accessory Set includes attachments for PASCO Force Sensors. These attachments are ideal for measuring forces during elastic and inelastic collisions between carts. Remove the hooks from the Force Sensors and replace with the included components.

Suggested Activities

Elastic Collisions

1. Remove the hooks from both Force Sensors
2. Screw the Clay Holder into one of the sensors
3. Screw either the Light Spring or Heavy Spring Bumper into the other Force Sensor
4. Connect the Force Sensors to PASCO carts.

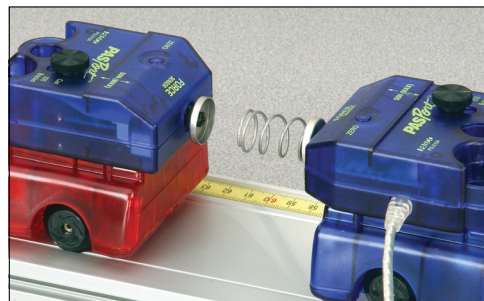

Inelastic Collisions

1. Remove the hooks from both Force Sensors
2. Screw a Clay Holder into each of the sensors
3. Form a clay cone and place it in one of the Clay Holders.
4. Connect the Force Sensors to PASCO carts.
5. Experiment with the effects of elongating the cone on the maximum force and time of collision.

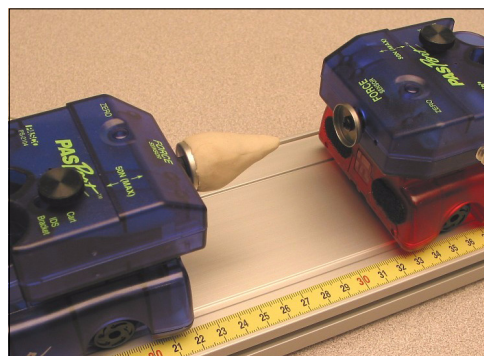

Technical Support

For assistance with any PASCO product, contact PASCO at:

Address: PASCO scientific
10101 Foothills Blvd.
Roseville, CA 95747-7100

Phone: 916-786-3800 (worldwide)
800-772-8700 (U.S.)

Fax: (916) 786-7565

Web: www.pasco.com

Email: support@pasco.com

Limited Warranty For a description of the product warranty, see the PASCO catalog.

Copyright The PASCO scientific 012-09157B *Bumper Accessory Set Instruction Sheet* is copyrighted with all rights reserved. Permission is granted to non-profit educational institutions for reproduction of any part of this manual, providing the reproductions are used only in their laboratories and classrooms, and are not sold for profit. Reproduction under any other circumstances, without the written consent of PASCO scientific, is prohibited.

Trademarks PASCO, PASCO scientific, DataStudio, ezSample, PASPORT, and Xplorer GLX are trademarks or registered trademarks of PASCO scientific, in the United States and/or in other countries. All other brands, products, or service names are or may be trademarks or service marks of, and are used to identify, products or services of, their respective owners. For more information visit www.pasco.com/legal.

Mass and Hanger Set

ME-8979

Included Parts	Quantity
100 g mass	3
50 g mass	3
20 g mass	6
10 g mass	3
5 g mass	3
2 g mass	3
1 g mass	3
0.5 g mass	3
Mass Hanger	4
Storage Box	1

Replacement Kits	Model Number
Spares Kit including: 3 × 2 g masses 3 × 1g masses 3 × 0.5 g masses 4 × mass hangers	ME-8980
5 g masses, set of 5	ME-8981
10 g masses, set of 5	ME-8982
20 g masses, set of 5	ME-8983
50 g masses, set of 5	ME-8984
100 g masses, set of 5	ME-8985

String Attachment

Pull string into notch and wrap a few times.

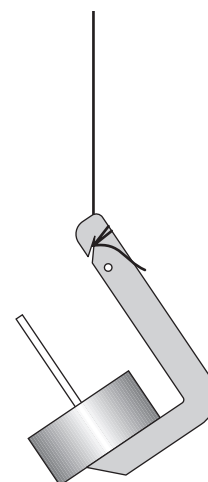

Technical Support

Address: PASCO scientific
10101 Foothills Blvd.
Roseville, CA 95747-7100

Phone: 916-786-3800 (worldwide)
800-772-8700 (U.S.)

Fax: (916) 786-7565

Web: www.pasco.com

Email: support@pasco.com

Limited Warranty For a description of the product warranty, see the PASCO catalog.

The PASCO scientific 012-10141A *Mass and Hanger Set Instruction Sheet* is copyrighted with all rights reserved. Permission is granted to non-profit educational institutions for reproduction of any part of this manual, providing the reproductions are used only in their laboratories and classrooms, and are not sold for profit. Reproduction under any other circumstances, without the written consent of PASCO scientific, is prohibited.

PASCO and PASCO scientific are trademarks or registered trademarks of PASCO scientific, in the United States and/or in other countries.

PATrack

ME-6960

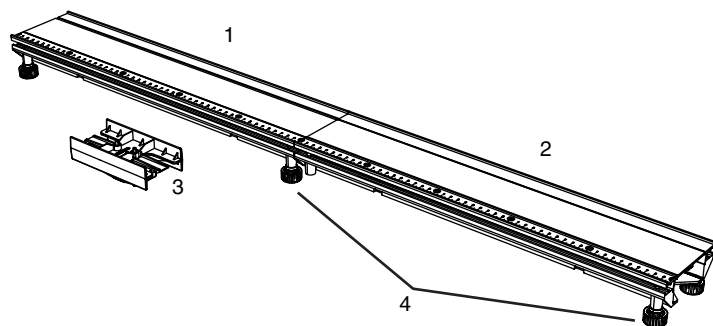

Included Equipment

1. 0 cm to 50 cm section
2. 50 cm to 100 cm section
3. Connectors (2 pieces)
4. Leveling Feet with locknuts (6 pieces)

Quick Start

1. Connect the track sections using one of the connector pieces.
2. Tighten the screws on the connector.

Introduction

The PATrack is designed for use with PASCO carts, dynamics system accessories, and optics carriages.

The model ME-6960 track consists of two sections that can be joined together with the included connector and split apart for storage. Together the two sections form a 1 m track. Each PATrack kit includes an extra connector, allowing any number of tracks to be joined together.

You can use the PATrack on a level surface or elevate one end to make an inclined plane.

Parts of the PATrack

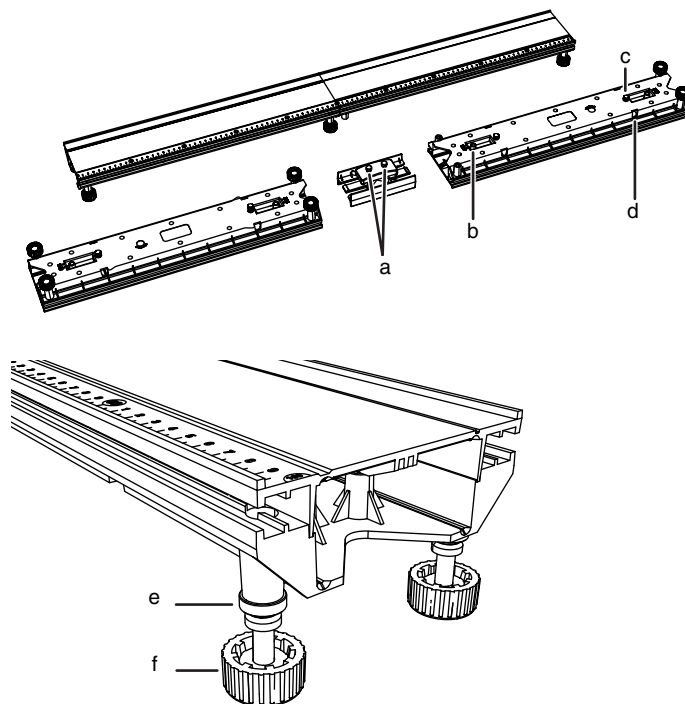

Figure 1

- a. Connector screws
- b. Release tab
- c. Rod clamp screw
- d. Rod clamp hole
- e. lock nut
- f. foot

Assembly

1. Slide a connector piece into the “50 cm” end of one track section. Push it hard until you hear it snap.

- Slide the other track section onto the connector piece. Push it until it snaps.
- Turn the track upside down and tighten the screws on the connector (part a in figure 1).

Leveling

- Set the track upright on a level surface.
- Place a cart on the track to test it for level.
- Adjust the feet to make the track straight and level.
- Tighten the locknut of each foot (part e in figure 1).

Rod Mounting

You can use a horizontal rod to elevate one end of the PAStack to incline it or two horizontal rods to raise the entire track for display. The PAStack accepts rods up to 9.5 mm in diameter (such as PASCO part SA-9242).

Insert a rod into one of the rod clamp holes (figure 2) and secure it by tightening the rod clamp screw (part c in figure 1). Clamp the horizontal rod to a vertical rod.

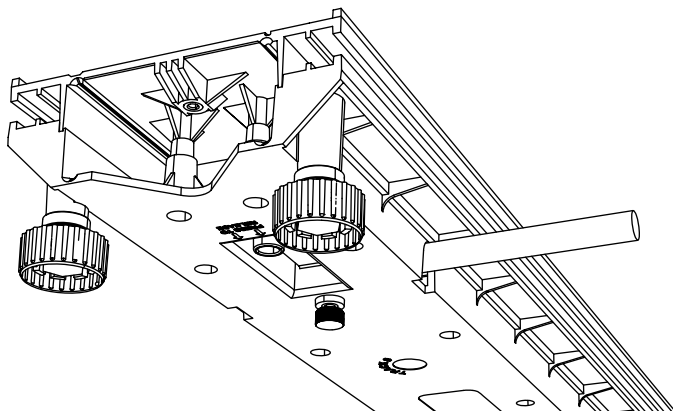

Figure 2

Disassembly

- Loosen the connector screws.
- Press and hold the release tabs on the bottom of the track (part b in figure 1).
- Pull the track sections apart.

For Best Results

- Engage and disengage each new connector several times to break it in and make subsequent assembly easier.
- If one end of the PAStack is elevated, ensure that the connector screws are tightened to prevent the track from bowing.
- If you are using multiple PAStacks joined together on a level surface, leave the connector screws loose. This will make each joint slightly flexible and allow you to use the feet to level each section separately.
- To protect your PAStack during storage, disassemble it and keep it in its original box.

Technical Support

For assistance with any PASCO product, contact PASCO at:

Address: PASCO scientific
10101 Foothills Blvd.
Roseville, CA 95747-7100

Phone: 916-786-3800 (worldwide)
800-772-8700 (U.S.)

Fax: (916) 786-7565

Web: www.pasco.com

Email: support@pasco.com

Limited Warranty For a description of the product warranty, see the PASCO catalog.

Copyright The PASCO scientific 012-10384A *PAStack Instruction Sheet* is copyrighted with all rights reserved. Permission is granted to non-profit educational institutions for reproduction of any part of this manual, providing the reproductions are used only in their laboratories and classrooms, and are not sold for profit. Reproduction under any other circumstances, without the written consent of PASCO scientific, is prohibited.

Trademarks PASCO and PASCO scientific are trademarks or registered trademarks of PASCO scientific, in the United States and/or in other countries. All other brands, products, or service names are or may be trademarks or service marks of, and are used to identify, products or services of, their respective owners. For more information visit www.pasco.com/legal.

Replacement Plumb Bobs (24)

ME-9868A

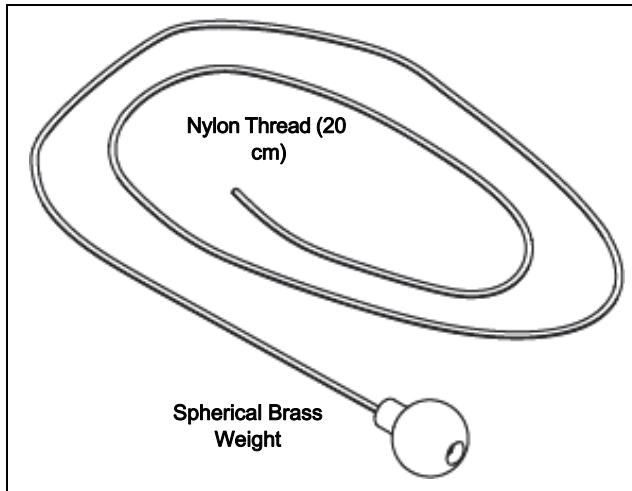

Introduction

Each Replacement Plumb Bob consists of a spherical brass weight attached to a length of nylon thread approximately 20 cm (8 in) long. Twenty-four of the plumb bobs are individually packaged in a bag. The Replacement Plumb Bob is designed to be used with the PASCO products that come with a plumb bob. These include the following:

- ME-6800 Projectile Launcher
- ME-6825B Mini Launcher
- ME-9495A Angle Indicator
- Inclined Plane Assembly (part of ME-9505 Statics Components Package)

(Check the PASCO web site at:

www.pasco.com

for future products that have a plumb bob.)

Also included with the Replacement Plumb Bobs are twenty-four small washers that let you attach the thread of the plumb bob to the ME-6800 Projectile

Launcher more easily. The other products have their own built-in, easy-to-use devices for attaching the thread.

Usage

Projectile Launcher (ME-6800)

1. Feed the thread from the front of the launcher through the hole in the label and the launcher cylinder.
2. Tie the thread loosely one time around a washer.
3. Hold the free end of the thread. Pull the washer so it is against the launcher cylinder and adjust the thread length so that the brass weight can just swing past the label corner.

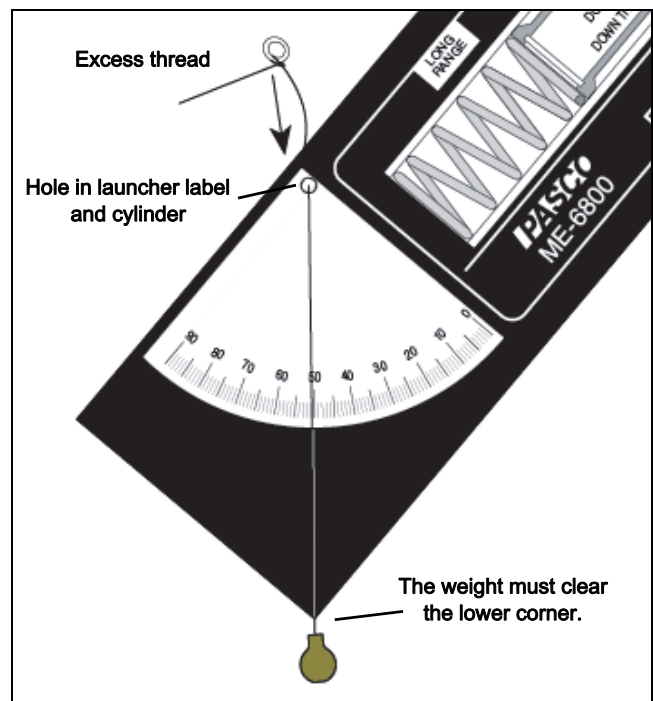

NOTE: The weight must be able to swing past the lower corner of the launcher in all orientations.

- Secure the thread with a double or triple knot to the washer. Be careful not to change the length of the thread. Trim any excess thread above the washer.

Mini Launcher (ME-6825B)

The plumb bob thread is held in place by a lever at the top of the cylinder on the Mini Launcher. The lever has a tab at one end. The outline of the lever is shown as a dashed line in the illustration.

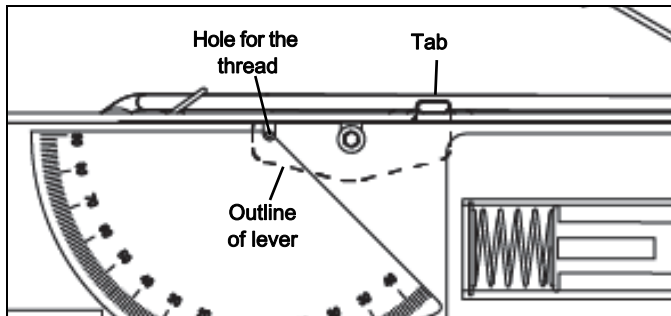

Pull the tab upward so that the lever is in the “up” position. Put the end of the plumb bob thread through the hole in the label and cylinder. **NOTE:** Arrange the thread so that the brass weight can just swing by the lower corner of the launcher in all orientations.

Push the tab down so that the lever holds the thread in place. Trim the excess thread.

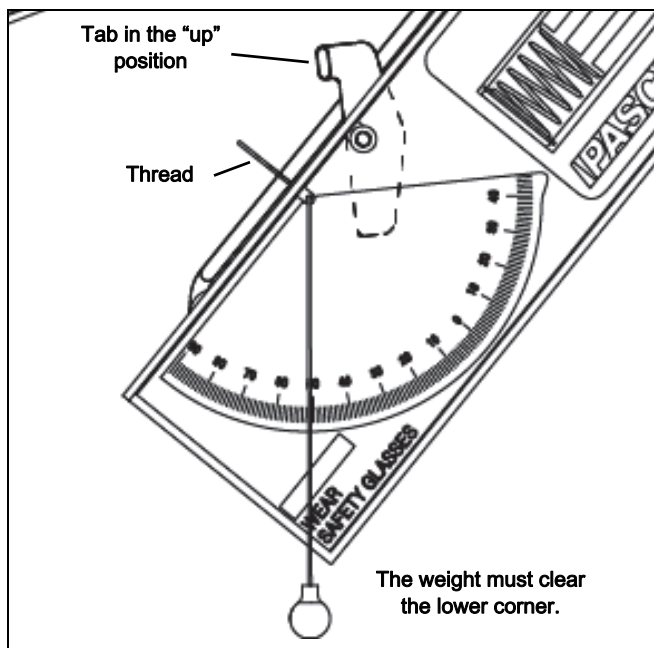

NOTE: Use the same procedure as described for the Projectile Launcher to attach a plumb bob to older model Mini Launchers that do not have the lever.

Angle Indicator (ME-9495A)

The thread that supports the spherical weight is attached to the back of the Angle Indicator with a screw.

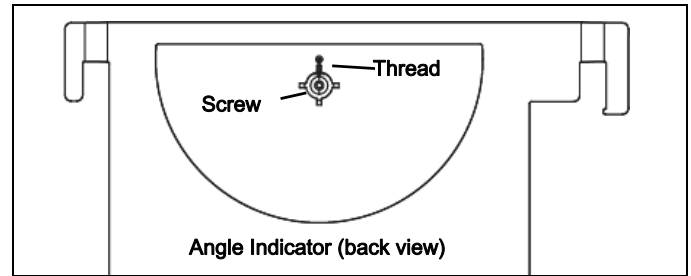

Put the thread through the hole on the front of the label. Make sure that the brass weight can swing just below the label. Loosen the screw and wrap the thread around the screw. Tighten the screw to hold the thread in place.

Inclined Plane Assembly (Part of ME-9505 Statics Components Package)

The plumb bob on the Inclined Plane Assembly can be replaced using the same procedure as for the Angle Indicator. The thread that supports the spherical weight is attached to the back of the Inclined Plane with a screw.

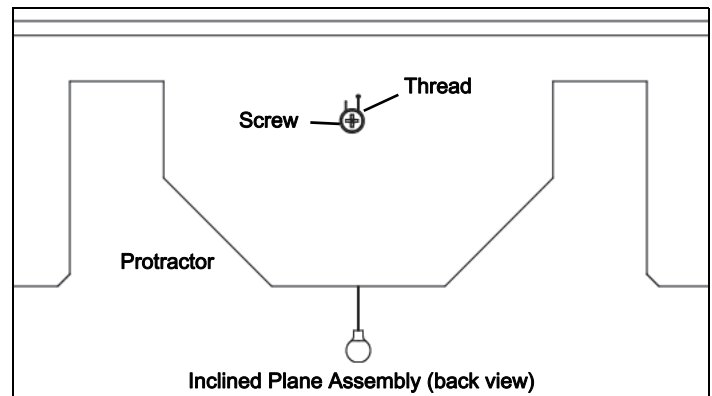

Put the thread through the hole on the front. Make sure that the brass weight can swing below each part of the protractor. Loosen the screw and wrap the thread around the screw. Tighten the screw to hold the thread in place.

Replacement Products

In addition to the ME-9868A Replacement Plumb Bobs package, there are other replacement products that include the plumb bobs (24 each).

- ME-6802 Launcher Spares Kit

- ME-6824 Mini Launcher Spares Kit

See the PASCO web site at

www.pasco.com

for the specific information about what is included in the spares kits.

Technical Support

For assistance with any PASCO product, contact PASCO at:

Address: PASCO scientific
10101 Foothills Blvd.
Roseville, CA 95747-7100

Phone: 916-462-8384 (worldwide)
800-772-8700 (U.S)

Email: techsupp@pasco.com

Web: www.pasco.com/support

Limited Warranty

For a description of the product warranty, see the PASCO web site.

Copyright

This PASCO scientific *Reference Guide* is copyrighted with all rights reserved. Permission is granted to non-profit educational institutions for reproduction of any part of this manual, providing the reproductions are used only in their laboratories and classrooms, and are not sold for profit. Reproduction under any other circumstances, without the written consent of PASCO scientific, is prohibited. Rev: 12/17

Trademarks

PASCO, PASCO scientific, PASCO Capstone, PASPORT and SPARKvue are trademarks or registered trademarks of PASCO scientific, in the United States and/or in other countries. All other brands, products, or service names are or may be trademarks or service marks of, and are used to identify, products or services of, their respective owners. For more information visit www.pasco.com/legal.

Smart Cart Rod Stand Adapter

ME-1244

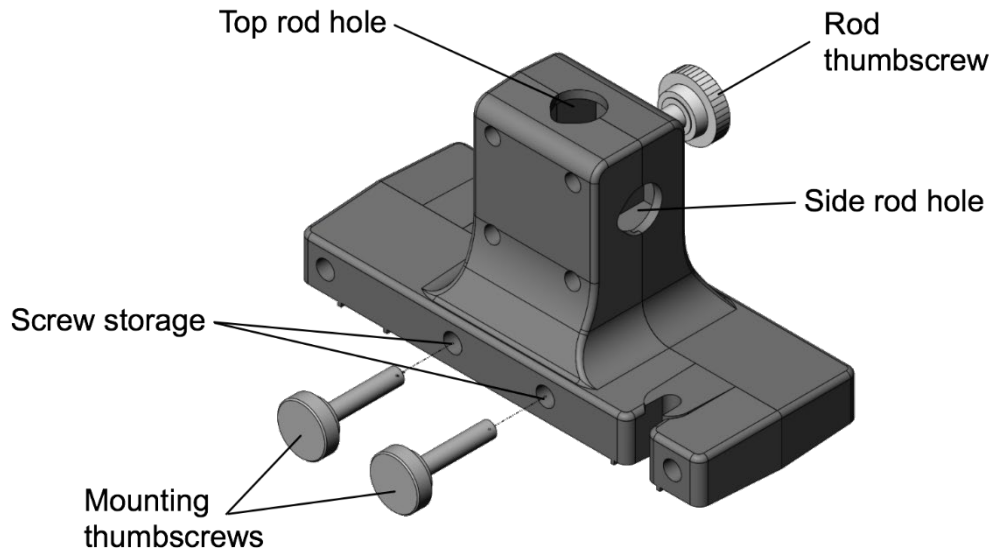

Introduction

The Smart Cart Rod Stand Adapter allows the PASCO Smart Cart to be suspended from a rod stand to measure forces with the Smart Cart force sensor. The adapter is precision made to fit securely in the accessory tray of Smart Cart models ME-1240 (red) or ME-1241 (blue). Built-in threaded screw storage holes provide a place to store the mounting thumbscrews when the adapter is not in use.

The Rod Stand Adapter accepts 3/8-inch (9.5 mm) to 1/2-inch (12.7 mm) rods. The Smart Cart can be mounted directly to a vertical rod to position the force sensor in a vertical direction. A second hole on the top of the Rod Stand Adapter allows the Smart Cart to be mounted to a horizontal cross-rod. When mounted to a horizontal rod, the force sensor can be placed further from the vertical rod and positioned at any angle.

Experiments performed with the Smart Cart Rod Stand Adapter determines how the adapter should be mounted. Mounting the Smart Cart vertically provides a stable setup for measuring the weight of a mass and the force of an oscillating mass on a spring. Mounting the Smart Cart on a horizontal rod is useful for statics experiments since forces can be measured at any angle.

Operation

To install the adapter

1. Remove the mounting thumbscrews from the screw storage holes.
2. Place the adapter in the accessory tray of the Smart Cart (Figure 1).
3. Insert in the thumbscrews into each threaded hole of the Smart Cart and turn until finger-tight.

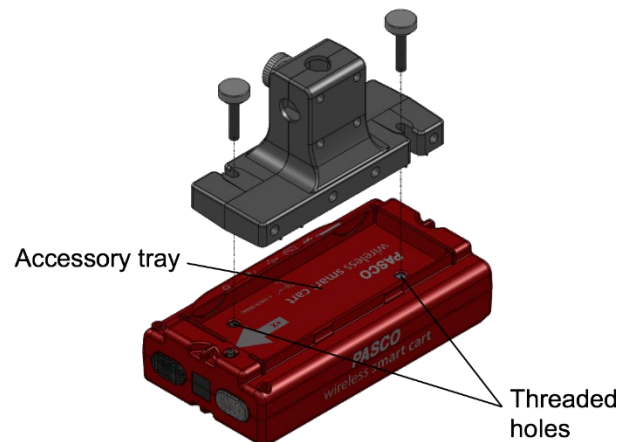

Figure 1. Place the adapter in the Smart Cart accessory tray.

To mount to a vertical rod

1. Loosen the rod screw to allow a rod to be inserted into the rod holes.
2. Insert a rod into the side rod hole (Figure 2, left).
3. Tighten the rod screw until finger-tight.

To mount to a horizontal rod

1. Set up two rods with a multi-clamp as shown in Figure 2 (right).
2. Loosen the rod screw to allow a rod to be inserted into the mounting hole.
3. Insert a rod into the top rod hole until the rod touches the bottom of the adapter.
4. Rotate the Smart Cart to the desired angle.
5. Tighten the rod screw until finger-tight.



Figure 2. The Smart Cart can be mounted directly to a vertical rod (left) or to a horizontal cross-rod (right).

Technical Support

For assistance with PASCO products, contact PASCO at:

Address: PASCO scientific
10101 Foothills Blvd.
Roseville, CA 95747-7100

Phone: 916-462-838

Web: www.pasco.com

Email: support@pasco.com

Warranty, Copyright, and Trademarks

Limited Warranty For a description of the product warranty, see the PASCO catalog.

Copyright The PASCO scientific 012-16466A Smart Cart Rod Stand Adapter Instruction Sheet is copyrighted with all rights reserved. Permission is granted to non-profit educational institutions for reproduction of any part of this manual, providing the reproductions are used only in their laboratories and classrooms, and are not sold for profit. Reproduction under any other circumstances, without the written consent of PASCO scientific, is prohibited.

Trademarks PASCO and PASCO scientific are trademarks or registered trademarks of PASCO scientific, in the United States and/or in other countries. All other brands, products, or service names are or may be trademarks or service marks of, and are used to identify, products or services of, their respective owners. For more information visit www.pasco.com/legal.



Super Pulley Kit

ME-9433

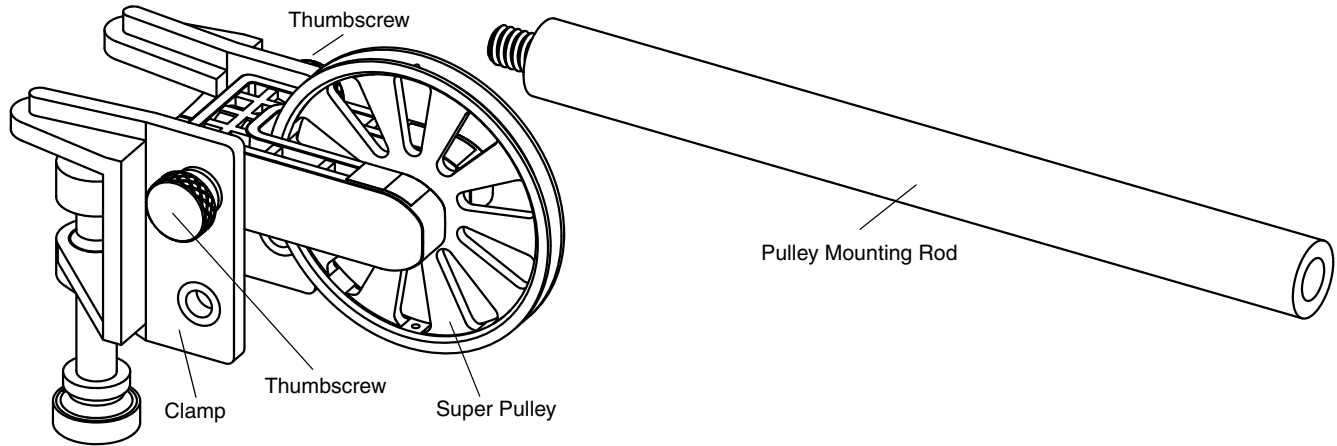

Introduction

The ME-9433 Super Pulley Kit consists of the ME-9448B Super Pulley with Clamp and a Pulley Mounting Rod.

The Super Pulley with Clamp is designed to be used whenever an integral clamp that features the low friction characteristics of the PASCO Super Pulley is needed. The clamp has two positions for attaching the Super Pulley. The pulley can be moved from one position to the other by removing two thumbscrews on either side of the clamp. Once the pulley is in the desired position, replace the thumbscrews to hold the pulley in place.

Specifications

The Super Pulley with Clamp fits tables up to 1.905 cm ($\frac{3}{4}$ ") thick.

Pulley specifications:

Diameter	5.1 cm (2 inches)
Outside circumference	16 cm (6.3 inches)
Groove circumference	15 cm (5.9 inches)
Mass	5 g (0.005 kg)
Moment of inertia (approx.)	$1.86 \times 10^{-6} \text{ kg m}^2$

Helpful Hints

When using the Super Pulley with Clamp on a force table,* keep strings as close and parallel to the surface of the table as possible. See Figure 1..

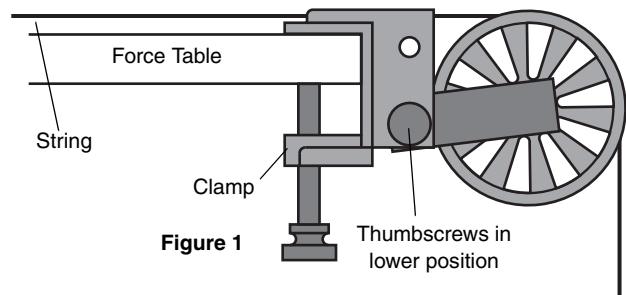

Strings should also remain parallel when using the Super Pulley with Clamp on inclined planes*, tracks*, or any table that might be used for demonstration. See Figure 2.

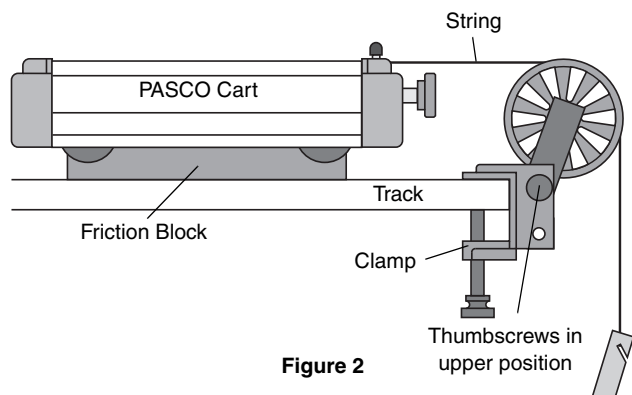

Figure 2

*See the PASCO catalog or web site at www.pasco.com for more information.

Usage

The Super Pulley with Clamp is included in several PASCO systems and is designed to work with a variety of PASCO equipment. The following is a list of some of the systems.

Systems

- Centripetal Force Accessory Kit (ME-8952)
- Mini-Rotational Accessory (CI-6691)
- PAStack Standard Dynamics System (ME-6961)
- Inclined Plane Dynamics Set (ME-6966)
- Physics Structures Set (ME-6989)
- 1.2 m and 2.2 m Classic Dynamics Systems
- 1.2 m and 2.2 m PAScar Dynamics Systems

Pulley Mounting Rod

The Super Pulley can be removed from the clamp and used with the Pulley Mounting Rod. The mounting rod fits into the threaded hole on the bottom of the pulley housing.

The Super Pulley and Pulley Mounting Rod can be used with a Photogate Head (ME-9498A) to form a "Smart Pulley".

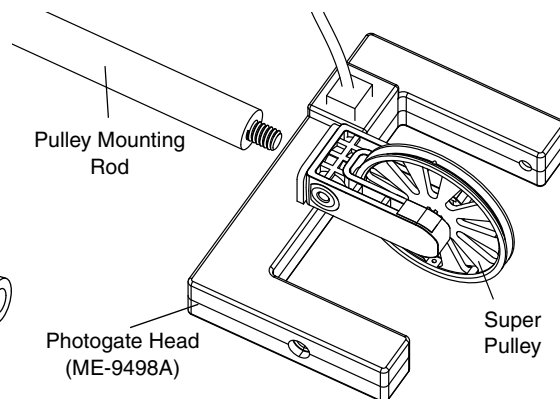
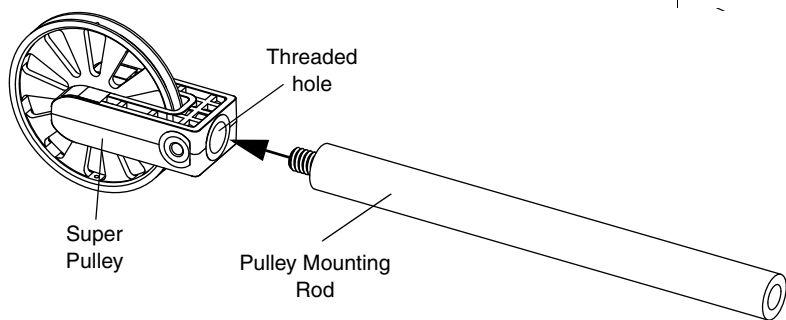

Technical Support

For assistance with any PASCO product, contact PASCO at:

Address: PASCO scientific
10101 Foothills Blvd.
Roseville, CA 95747-7100

Phone: 916-786-3800 (worldwide)
800-772-8700 (U.S.)

Fax: (916) 786-7565

Web: www.pasco.com

Email: support@pasco.com

Limited Warranty For a description of the product warranty, see the PASCO catalog. **Copyright** The PASCO scientific 012-12559A *Super Pulley Kit Instruction Sheet* reserved. Permission is granted to non-profit educational institutions for reproduction of any part of this manual, providing the reproductions are used only in their laboratories and classrooms, and are not sold for profit. Reproduction under any other circumstances, without the written consent of PASCO scientific, is prohibited. **Trademarks**

scientific, in the United States and/or in other countries. All other brands, products, or service names are or may be trademarks or service marks of, and are used to identify, products or services of, their respective owners. For more information visit www.pasco.com/legal.

For more information about the Super Pulley Kit and the latest revision of this Instruction Sheet, visit:

www.pasco.com/go?ME-9433

Wireless Smart Cart [ME-1240 (Red) / ME-1241 (Blue)]

Introduction

The Wireless Smart Cart is a combination wireless *and* USB device that connects to a computer or tablet through Bluetooth, or to a computer or USB charger through an included micro USB cable. The Smart Cart has a durable ABS body, a three-position plunger, and nearly frictionless wheels. It includes built-in sensors which measure acceleration in three dimensions, position, velocity, and force. The Smart Cart also includes a gyroscope-type sensing element which can measure rotational motion. The Smart Cart can make its measurements on or off a dynamics track and transmit them wirelessly. For easy identification, the Smart Cart is available in red or blue.

The accessory tray on the top of the Smart Cart can hold any accessory designed for a PASCO cart except the Spring Cart Launcher (ME-6843). The Smart Cart has the same dimensions as other PASCO carts and can be used with any PASCO track. The Smart Cart can be stacked with any PASCO cart and has a mass of approximately 0.250 kilograms (250 grams). It has attachment points on the top and bottom of both ends, as well as Velcro® tabs for inelastic collisions on one end. The magnetic bumper, bumper attachment, and hook attachment fit into the threaded hole in the end of the Smart Cart opposite to the tabs.

The built-in sensors measure force in the range between -100 newtons (N) and +100 N, acceleration in the range between -16 g and +16 g (where $g = \pm 9.8 \text{ m/s}^2$), and angular rotation rate up to ± 145 degrees per second (dps). The cart measures force as a push or pull along its x-axis and measures acceleration in three dimensions (x, y, and z). PASCO Capstone or SPARKvue can also show the resultant acceleration. The encoder wheels on the Smart Cart measure velocity to a maximum of 3.0 meters per second; the wheels have a position resolution of 0.2 mm. The positive direction of motion is the same as the x-axis in the printed graphic representing the acceleration sensor's position.

The Smart Cart is designed to optimize battery usage time and will turn off after about five minutes if not connected to the software. Since each Smart Cart has a unique device ID number, more than one can be connected to a computer or tablet at once.

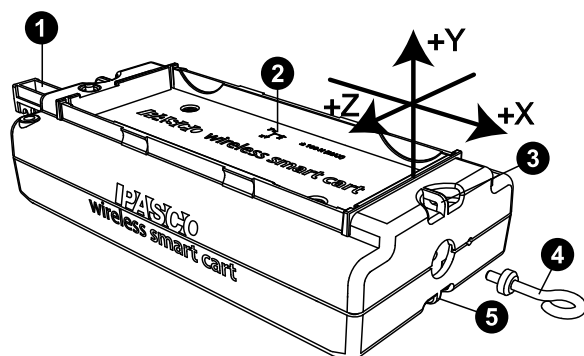

- 1 Three-position plunger
- 2 Acceleration and gyro sensor position
- 3 Attachment point
- 4 Hook attachment
- 5 Attachment point

Equipment

Included equipment:

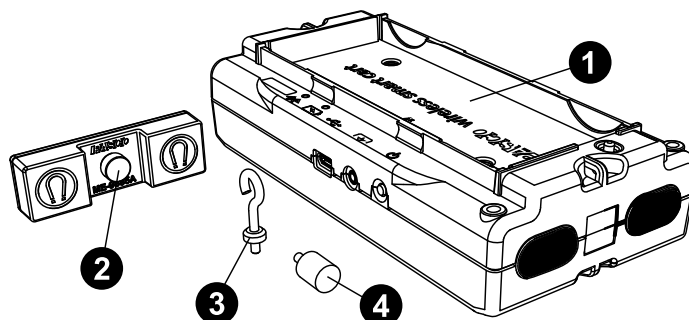

- 1 Wireless Smart Cart (ME-1240 or ME-1241)
- 2 Magnetic bumper
- 3 Bumper attachment
- 4 Hook attachment
- 5 Micro USB cable (not pictured)

Features:

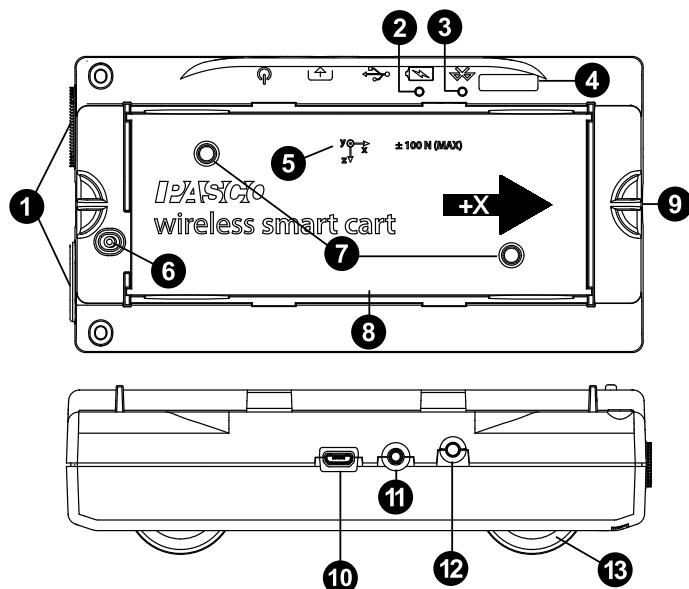

- 1 Velcro® tab
Allows two carts to attach to each other in an inelastic collision.
- 2 Battery Status LED
Indicates the charge level and status of the cart's battery.

Battery LED	Status
Red blink	Low power
Yellow ON	Charging
Green ON	Fully charged

3 Bluetooth Status LED

Indicates the status of the cart's Bluetooth connection.

Bluetooth LED	Status
Red blink	Ready to pair
Green blink	Connected



NOTE: The Bluetooth LED will not light up if the sensor is connected to the software via micro USB cable.

4 Device ID

Use this to identify the cart when connecting via Bluetooth.

5 Accelerometer position

Indicates the position of the acceleration and gyro sensor within the cart, as well as the direction of the three dimensions of acceleration (the x-axis, y-axis, and z-axis).

6 Plunger release

Press to immediately release the plunger to its maximum extension.

7 Threaded holes (M5)

Use to secure accessories in place on top of the cart.

8 Accessory tray

Use to hold accessories mounted on the cart.

9 Attachment point

Use these points to tie a string to the cart for various experiments.

10 Micro USB port

Use with the included micro USB cable to connect the cart to a USB charger. The port and cable can also be used to directly connect the cart to a computer without the use of Bluetooth. This connection method is not supported by iOS.

11 Accessory port

Use to connect various accessories to the Smart Cart, enable data collection from them, and control them.

12 ON/OFF button

Press to turn the cart on. Press and briefly hold to turn the cart off.

13 Built-in wheel encoder

Used to automatically record position, velocity, and acceleration of the wheels during data collection.

Required equipment:

- Data collection software (PASCO Capstone or SPARKvue)

Initial step: Charge the battery

Charge the battery by connecting the USB port to any standard USB charger. The Smart Cart Charging Garage (ME-1243) allows up to five Smart Carts to be charged simultaneously, while also serving as a storage option for the cart and bumpers. The battery status light is solid yellow while charging. When fully charged, the light changes to solid green.

Get the software

You can use the Smart Cart with SPARKvue or PASCO Capstone software. If you're not sure which to use, visit [pasco.com/products/guides/software-comparison](https://www.pasco.com/products/guides/software-comparison).

SPARKvue is available as a free app for Chromebook, iOS, and Android devices. We offer a free trial of SPARKvue and Capstone for Windows and Mac. To get the software, go to [pasco.com/downloads](https://www.pasco.com/downloads) or search for **SPARKvue** in your device's app store.

If you have installed the software previously, check that you have the latest update:

SPARKvue

Go to Main Menu  > **Check for Updates**

PASCO Capstone

Go to **Help** > **Check for Updates**.

The Wireless Smart Cart can also be used with the free PASCO program MatchGraph!, which can be downloaded at [pasco.com/matchgraph](https://www.pasco.com/matchgraph).

Check for a firmware update**SPARKvue**

1. Press the power button until the lights turn on.
2. Open SPARKvue.
3. Select **Sensor Data** on the Welcome Screen.



4. Select the sensor that matches your sensor's device ID. A notification appears if a firmware update is available. Click **Yes** to update the firmware.
5. Close SPARKvue.

PASCO Capstone

1. Press and hold the power button until the lights turn on.
2. Open PASCO Capstone.
3. Click **Hardware Setup**.



4. Select the sensor that matches your sensor's device ID. A notification appears if a firmware update is available. Click **Yes** to update the firmware.
5. Close Capstone.

Setting up the software

Collecting data from the Smart Cart requires PASCO Capstone, SPARKvue, or MatchGraph! software. The Smart Cart can be connected to any of these programs using either Bluetooth or a USB connection.

SPARKvue

To connect to SPARKvue using Bluetooth:

1. Turn on the Smart Cart. Check to make sure that the Bluetooth LED is blinking red.
2. Start SPARKvue, then select **Sensor Data** from the main menu.
3. From the list of available wireless devices, select the Smart Cart which matches the device ID (XXX-XXX) printed on your Smart Cart to connect to the cart.

To connect to SPARKvue using the micro USB cable:

1. Turn on the Smart Cart.
2. Start SPARKvue, then select **Sensor Data** from the main menu.
3. Connect the micro USB cable (included) from the micro USB port on the Smart Cart to a USB port on the computer, or into a powered USB hub connected to the computer. The cart will connect automatically.

Upon connecting to the Smart Cart, a list of available Smart Cart sensor measurements will automatically appear in the **Select Measurements for Templates** section.

To collect data with SPARKvue:

1. From the **Sensor Data** menu, after connecting to the Smart Cart, enable the desired measurements by clicking the checkboxes next to those measurements.
2. In the **Templates** section, select **Graph** to enter the Experiment Screen.
3. The Graph template will automatically populate the axes with the measurements you selected on the y-axis (or y-axes if you selected multiple measurements) and time on the x-axis. To change the quantity measured on an axis, click the buttons displaying the current measurement, then select the appropriate quantity from the list.
4. When you are ready, click **Start**  to begin collecting data.

PASCO Capstone

To connect to Capstone using Bluetooth:

1. Turn on the Smart Cart.
2. Start Capstone, then select **Hardware Setup**  from the **Tools** palette.
3. From the list of **Available Wireless Devices**, select the Smart Cart which matches the device ID (XXX-XXX) printed on your Smart Cart to connect to the cart.

To connect to Capstone using the micro USB cable:

1. Turn on the Smart Cart.
2. Start Capstone. If desired, select **Hardware Setup**  from the **Tools** palette to verify the connection status.
3. Connect the micro USB cable (included) from the micro USB port on the Smart Cart to a USB port on the computer, or into a powered USB hub connected to the computer. The cart will connect automatically.

When connecting the Smart Cart to Capstone, the measurement of all sensors will be enabled by default. Any undesired measurements can be disabled through the **Data Summary**  menu in the **Tools** palette.

To collect data from Capstone:

1. Double-click the **Graph** icon in the **Displays** palette to create a new Graph display.
2. On each axis, click **<Select Measurement>**, then choose the appropriate sensor measurement for your experiment from the list.
3. When you are ready, click **Record**  to begin recording data.

MatchGraph!

To connect to MatchGraph! using Bluetooth:



1. Turn on the Smart Cart. Check to make sure that the Bluetooth LED is blinking red.
2. Start MatchGraph!. The **Sensor Not Found** window will open automatically.
3. Select **Choose Wireless Interface** from the bottom right corner of the **Sensor Not Found** window.
4. From the **Select Wireless Interface** list, select the Smart Cart which matches the device ID (XXX-XXX) printed on your Smart Cart to connect to the cart.

To connect to MatchGraph! using the micro USB cable:

1. Turn on the Smart Cart.
2. Connect the micro USB cable (included) from the micro USB port on the Smart Cart to a USB port on the computer, or into a powered USB hub connected to the computer.
3. Start MatchGraph!. The cart will connect automatically.

Note that MatchGraph! is only capable of tracking position and velocity data from the Smart Cart. Data from the cart's other measurements will not be collected.

To collect data from MatchGraph!:

1. Select whether you want to track position or velocity data from the Smart Cart.
2. Choose a profile to be displayed by clicking **View All Profiles**  at the top of the screen and selecting a profile from the list.
3. When you are ready, click **Record**  to begin tracking data.

Connecting bumper and hook attachments

Screw the bumper or hook attachment into the threaded hole on the front end of the Smart Cart, as shown below.

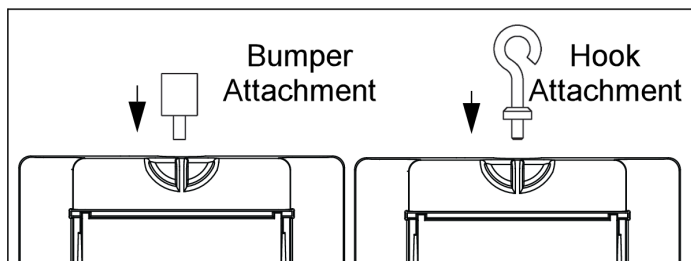

The magnetic bumper has a metal post that fits in the small hole to the side of the threaded hole on the front end of the Smart Cart, as shown below. The post ensures that the magnetic bumper is mounted in the correct orientation.

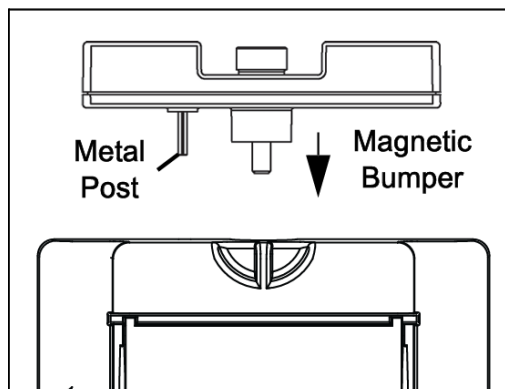

Screwing any of these attachments into the threaded hole on the front end of the Smart Cart connects them to the Smart Cart's built-in Force Sensor, allowing measurements of the force on the cart to be collected.



IMPORTANT: If using the Smart Cart for collisions, do NOT use the rubber bumper, as the force of impact on the bumper may damage the internal force sensor. Instead, any of the following components can be used as a bumper for collision experiments:

- Light Spring Bumper (ME-9275)
- Bumper Accessory Set (ME-9884)
- Magnetic Bumper Set (ME-9885A)

Direction of acceleration

The acceleration sensing unit inside the Smart Cart is oriented so that the acceleration axes are aligned with the x - y - z arrows indicating the direction of positive acceleration.

In this orientation, the x -axis direction is 'along' the long axis of the Smart Cart; the y -axis direction is 'perpendicular' relative to the top of the Smart Cart; and the z -axis direction is 'perpendicular' to the long axis of the Smart Cart and parallel relative to the top of the cart.

Zero (tare) the sensors

At the beginning of an experiment, the measurement from the built-in force and acceleration sensors may not be zero when the force or acceleration is actually zero. This is a normal behavior that is corrected when you zero (or *tare*) the sensor using PASCO Capstone or SPARKvue. For information on zeroing a sensor in these programs, see the Capstone or SPARKvue online help and search for "**Zero sensor**".

Calibration

The Smart Cart is factory calibrated, so calibration is not necessary, especially if you are measuring a change in a measurement rather than absolute values. However, it is possible to calibrate the sensors if desired. For information on calibrating a Smart Cart, see the PASCO Capstone or SPARKvue online help.



NOTE: Zeroing of the acceleration sensor should **only** be performed if you are measuring acceleration on only a single axis, as zeroing the sensor will cause the measurements of acceleration on the other two axes to no longer report accurate values.

Accessories

A number of accessories are available for the Wireless Smart Cart. Links to these products can be found on the product page. In particular, certain accessories are designed specifically to be used with the Wireless Smart Cart, including:

- Smart Fan Accessory (ME-1242)
- Smart Ballistic Cart Accessory (ME-1245)
- Smart Cart Vector Display (ME-1246)
- Smart Cart Motor (ME-1247)

For instructions on mounting these accessories to the Smart Cart, see the manual for the product in question.

Troubleshooting

- If the Wireless Smart Cart loses Bluetooth connection and will not reconnect, try cycling the ON button. Press and briefly **hold** the button until the status LEDs blink in sequence, then release the button. Start the Smart Cart in the usual way.
- If the Smart Cart stops communicating with the computer software or tablet application, try restarting the software or application. If the problem remains, press and hold the ON button for 10 seconds, then release. Start the Smart Cart in the usual way.
- If the above problems do not solve the connection issue, turn Bluetooth off and back on for your computer, then retry.

About the battery

The Smart Cart's battery is partially charged at the factory. If the battery status LED blinks red, use the micro USB cable to connect the sensor to a USB port or a USB charger.

Maximizing battery life

One of the factors that affects battery life is the storage temperature. Therefore, avoid storing the Smart Cart in very cold or very hot environments.

Battery troubleshooting

If the Smart Cart battery will not charge, it may need to be replaced. Contact Technical Support for information about battery replacement.

Software help

The SPARKvue and PASCO Capstone Help provide additional information on how to use this product with the software. You can access the help within the software or online.

SPARKvue

Software: Main Menu  > Help

Online: help.pasco.com/sparkvue

PASCO Capstone

Software: Help > PASCO Capstone Help

Online: help.pasco.com/capstone

Specifications and accessories

Visit the product page at pasco.com/product/me-1240 or pasco.com/product/me-1241 to view the specifications and explore accessories. You can also download experiment files and support documents from the product page.

Experiment files

Download one of several student-ready activities from the PASCO Experiment Library. Experiments include editable student handouts and teacher notes. Visit pasco.com/freelabs/me-1240 or pasco.com/freelabs/me-1241.

Technical support

Need more help? Our knowledgeable and friendly Technical Support staff is ready to answer your questions or walk you through any issues.

-  Chat pasco.com
-  Phone 1-800-772-8700 x1004 (USA)
+1 916 462 8384 (outside USA)
-  Email support@pasco.com

Regulatory information

Limited warranty

For a description of the product warranty, see the Warranty and Returns page at www.pasco.com/legal.

Copyright

This document is copyrighted with all rights reserved. Permission is granted to non-profit educational institutions for reproduction of any part of this manual, providing the reproductions are used only in their laboratories and classrooms, and are not sold for profit. Reproduction under any other circumstances, without the written consent of PASCO scientific, is prohibited.

Trademarks

PASCO and PASCO scientific are trademarks or registered trademarks of PASCO scientific, in the United States and in other countries. All other brands, products, or service names are or may be trademarks or service marks of, and are used to identify, products or services of, their respective owners. For more information visit www.pasco.com/legal.

Product end-of-life disposal



This electronic product is subject to disposal and recycling regulations that vary by country and region.

It is your responsibility to recycle your electronic equipment per your local environmental laws and regulations to ensure that it will be recycled in a manner that protects human health and the environment.

To find out where you can drop off your waste equipment for recycling, please contact your local waste recycle or disposal service, or the place where you purchased the product.

The European Union WEEE (Waste Electronic and Electrical Equipment) symbol on the product or its packaging indicates that this product must not be disposed of in a standard waste container.

CE statement

This device has been tested and found to comply with the essential requirements and other relevant provisions of the applicable EU Directives.

FCC statement

This device complies with part 15 of the FCC Rules.

Operation is subject to the following two conditions:

(1) This device may not cause harmful interference, and (2) this device must accept any interference received, including interference that may cause undesired operation.

Battery disposal



Batteries contain chemicals that, if released, may affect the environment and human health.

Batteries should be collected separately for recycling and recycled at a local hazardous material disposal location adhering to your country and local government regulations.

To find out where you can drop off your waste battery for recycling, please contact your local waste disposal service, or the product representative.

The battery used in this product is marked with the European Union symbol for waste batteries to indicate the need for the separate collection and recycling of batteries.

Patents

The Smart Cart (ME-1240 and ME-1241) is covered by U.S. Patent No. 10,481,173.

The Smart Fan Accessory (ME-1242) is covered by U.S. Patent No. 10,482,789.