

# Wireless Force-Acceleration Sensor

PS-3202

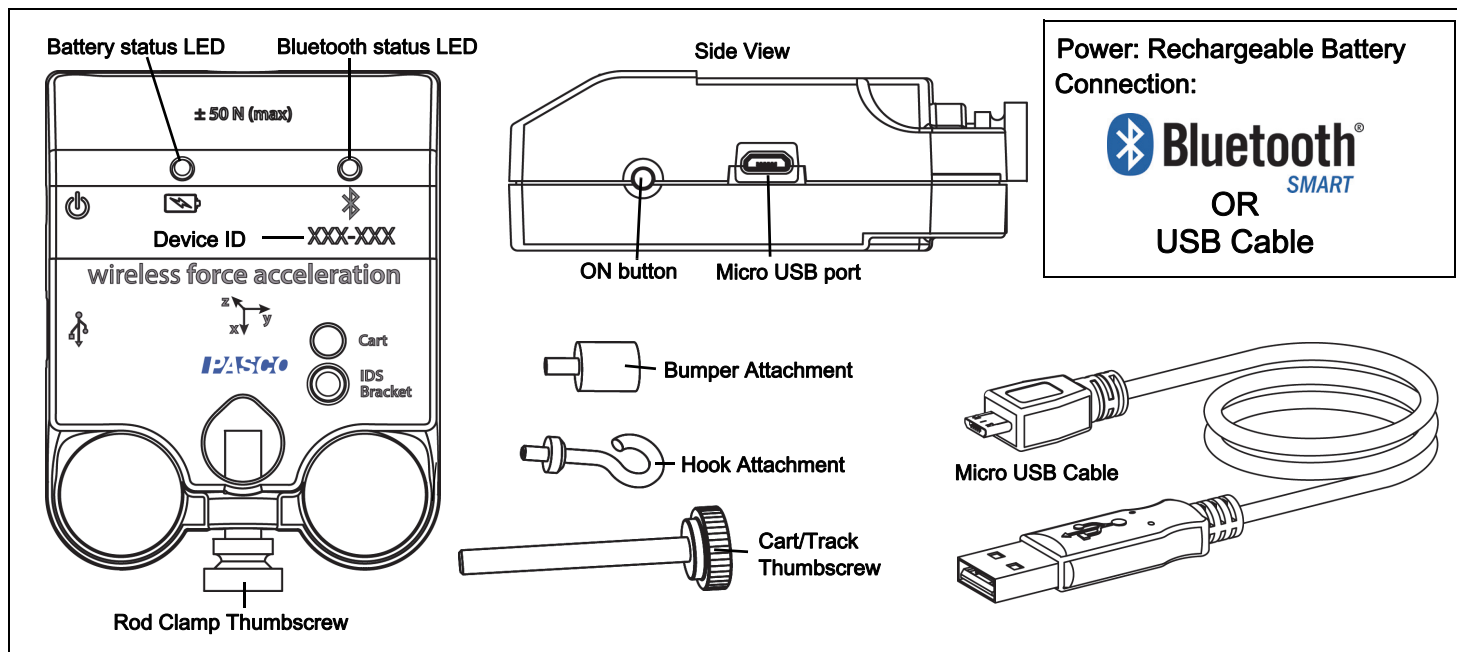

## Hardware

Included Equipment	Part Number
Wireless Force-Acceleration Sensor	PS-3202
Micro USB Cable (1 meter)	
Hook Attachment	
Cart/Track Thumbscrew	
Bumper Attachment	
Rod Clamp Thumbscrew	

## Introduction

The Wireless Force-Acceleration Sensor is a combination wireless *and* USB sensor that connects to a computer or tablet device through Bluetooth<sup>®</sup>, and can also connect to a computer with a USB cable (included). The sensor measures force up to  $\pm 50$  newtons (N), acceleration up to  $\pm 16$  g ( $1 \text{ g} = 9.8 \text{ m/s}^2$ ), and angular

rotation rate up to  $\pm 2000$  degrees per second (dps). The sensor measures force as a push or pull along its X axis and measures acceleration in three dimensions (X, Y, and Z). The PASCO Data Collection Software can show the resultant acceleration. The sensor uses a micro-electromechanical system (MEMS) device.

The sensor is designed to optimize the battery usage time. Since each sensor has a unique Device ID number, more than one can be connected to a computer or tablet at the same time.

## Data Collection Software

### PASCO Capstone



- Mac OS X
- Windows

### SPARKvue



- Mac OS X
- Windows
- iOS
- Android
- Chromebook

See the PASCO Web page at

[www.pasco.com/software](http://www.pasco.com/software)

for help in selecting the right PASCO software and to check the latest versions.

## Software Help

See the SPARKvue Help or PASCO Capstone Help for information about collecting, displaying, and analyzing data.

- In SPARKvue, select the HELP button ( ? ) in any screen including the Home Screen.
- In PASCO Capstone, select **PASCO Capstone Help** from the **Help** menu, or press **F1**.

## Bluetooth<sup>®</sup> Compatibility

Check the PASCO Web page at

[www.pasco.com/compatibility](http://www.pasco.com/compatibility)

for the latest information on Bluetooth SMART compatibility.

Platform	Bluetooth SMART Compatibility
iOS	iPad 3 and later iPhone 4S and later iPod touch 5 and later
SPARK Element	All models
Android	Android 4.3 and later
Chromebook	Chrome OS (requires PS-3500 Adapter*)
Mac OS X	Models introduced July 2011 or later*
Windows	Windows 7 and later (requires PS-3500 Adapter*)

See Appendix A for more information about the PS-3500 Adapter and Mac OS X models.

## Initial Step: Charge the Battery

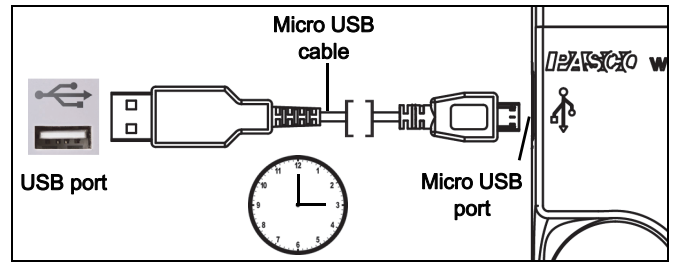

- **Connect the Cable:** Use the Micro USB Cable to connect the micro USB port on the Wireless Force-Acceleration Sensor to a USB port or USB charger such as the PASCO PS-3501 USB Charging Station. Charging begins automatically. The charger circuit inside the sensor turns itself off when the unit is fully charged. The battery status LED will shine yellow as the battery is charging, and will shine green when the battery is charged. The battery is partially charged at the factory. Initial charging time may be three hours or longer depending on the power source and the condition of the battery.

## ON/OFF Information

To turn the sensor off, press and hold the ON button for a moment until the status LEDs stop blinking. The Wireless Force-Acceleration Sensor puts itself to sleep after several minutes of inactivity if not connected and about one hour of inactivity if connected.

## LED Information

The Bluetooth and the Battery Status LEDs operate as follows depending on the type of connection:

### For a wireless Bluetooth connection:

Bluetooth LED	Status
Red blink	Ready to pair
Green blink	Connected
Yellow blink	Logging*

Battery LED	Status
Red blink	Low power

### For a micro USB cable connection to a USB port:

Bluetooth LED	Status
OFF	--

Battery LED	Status
Yellow ON	Charging

Bluetooth LED	Status
OFF	--
Yellow blink	Logging*

Battery LED	Status
Green ON	Charged

### For a micro USB cable connection to a USB *charger*

Bluetooth LED	Status
Red blink	Ready to pair
Green blink	Connected
Yellow blink	Logging*

Battery LED	Status
Yellow ON	Charging
Green ON	Charged

\***Logging:** PASCO wireless sensors can either stream live data to a compatible device or log data independently (save it to the sensor's onboard memory). The data can then be uploaded to the device for display and analysis at a later time. Logging capability supports long-term or remote data collection while not connected to a computing device.

Note: Both SPARKvue and PASCO Capstone support logging. Check the PASCO Web page at:

[www.pasco.com/software](http://www.pasco.com/software)

for the latest software version. Please check the software online help (User's Guide) for details about logging.

## Set Up the Software

### SPARKvue

#### Connecting the Wireless Sensor to a Tablet or a Computer via Bluetooth

- For SPARKvue, select the Bluetooth icon () to open the **Wireless Devices** list. In the **Wireless Devices** list, the sensors are ordered by proximity to the device. Select the correct address that matches the XXX-XXX number found on the sensor. Select **Done**. A list of measurements appears under the sensor in the **Home Screen**.

#### Connecting the Wireless Sensor to a Computer with the Micro USB Cable

- Connect the micro end of the included Micro USB Cable into the micro USB port on the end of the sensor. Connect the other end of the Micro USB Cable to a USB port on the computer, or into a powered USB hub connected to the computer.

### Zero (Tare) the Force-Acceleration Sensor

At the beginning of an experiment, the measurement from the sensor may not be zero when the force or acceleration is actually zero. This is a normal behavior that is corrected when you zero (or tare) the sensor using the PASCO Data Collection Software.

In SPARKvue, the process for setting the Wireless Force-Acceleration Sensor to zero starts in the Home Screen ()

- To zero the Wireless Force Sensor, start by selecting **Force** in the Home Screen to open a Graph display of Force versus Time.
- In the Graph display, select the **Experiment Tools** () icon to open the **Experiment Tools** window.
- In the **Experiment Tools** window, select **Configure Sensor** in the menu to open the **Sensor Configuration** window.
- In the **Sensor Configuration** window, select the **Edit Sensor Properties** button to open the **Edit Sensor Properties** menu.
- The **Edit Sensor Properties** menu shows two choices:
  - Wireless Force Sensor**
  - Wireless Acceleration Sensor**.
- Select the **Wireless Force Sensor** choice from the menu to open the **Edit Sensor Properties** window.
- The **Edit Sensor Properties** window offers two choices under **Tare Sensor**:
  - Zero Sensor Automatically On Start:**
  - Zero Sensor Now**
- In the **Edit Sensor Properties** window, select **Zero Sensor Automatically On Start** if you want the sensor to be set to zero every time that data collection begins. **Select Zero Sensor Now** to set the sensor to zero manually.
- Select **OK** at the bottom of the window to return to the Graph display.

To zero the acceleration for the Force-Acceleration Sensor, return to the **Home Screen** () (NOTE: There may be a message about saving your data.)

- To zero the **Wireless Acceleration Sensor**, start by selecting any of the choices for acceleration in the **Home Screen** to open a Graph display of Acceleration versus Time.
- In the Graph display, select the **Experiment Tools** () icon to open the **Experiment Tools** window.
- Follow the same procedure that you used for setting the force measurement of the Force-Acceleration Sensor to zero.

### Collect Data

- In the SPARKvue **Home Screen**, select a measurement from the list under the sensor's name. A graph of the measurement versus time opens.
- In SPARKvue, select the **Start** button () to begin collecting data.

## PASCO Capstone

### Connecting the Wireless Sensor to a Tablet or a Computer via Bluetooth

- For PASCO Capstone, select **Hardware Setup** in the Tools palette. The sensors in the list are ordered by proximity to the wireless device. Select the sensor with the address that matches the XXX-XXX Device ID number on the sensor.

### Connecting the Wireless Sensor to a Computer with the Micro USB Cable

- Connect the micro end of the included Micro USB Cable into the micro USB port on the end of the sensor. Connect the other end of the Micro USB Cable to a USB port on the computer, or into a powered USB hub connected to the computer.

### Zero (Tare) the Force-Acceleration Sensor

At the beginning of an experiment, the measurement from the sensor may not be zero when the force or acceleration is actually zero. This is a normal behavior that is corrected when you zero (or tare) the sensor using the PASCO Data Collection Software.

In PASCO Capstone, there are options for setting the Wireless Force-Acceleration Sensor to zero.

One option is to use the **Common Rate** button:

- Click the **Common Rate** button in the Control palette below the workbook to open the **Common Rate** menu.

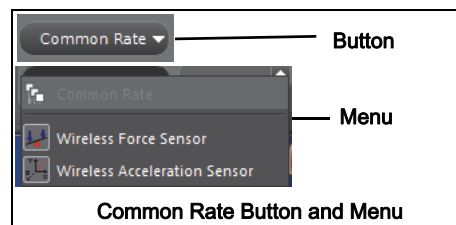

- Select **Wireless Force Sensor** from the menu and then click the zero button. This will set the sensor reading to zero.

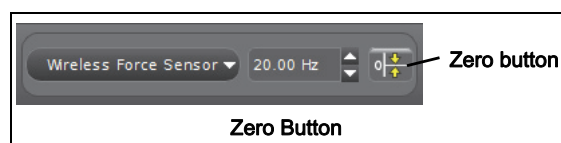

- Repeat the process to zero the "Wireless Acceleration Sensor" if needed.

Another option is to select a choice in the sensor's Properties palette:

- Click **Hardware Setup** in the Tools palette to open the **Hardware Setup** window.

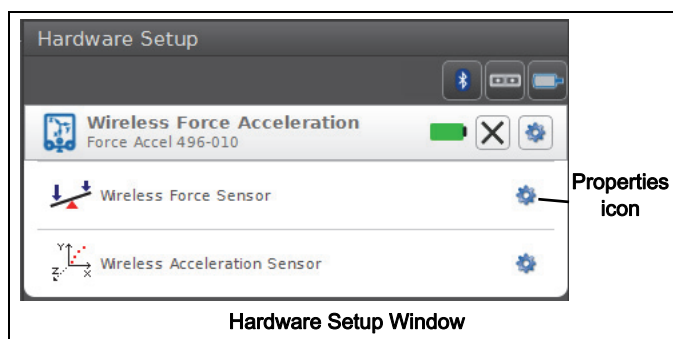

- Click the Properties icon for the **Wireless Force Sensor** in the **Hardware Setup** window to open the **Properties** window.

- In the **Properties** window, select one of the three choices and then click **OK** at the bottom to close the window.

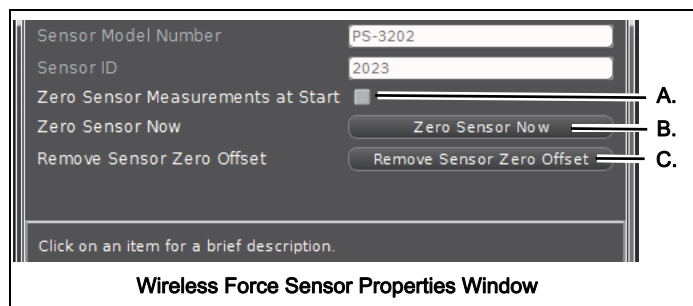

- Choice A: **Zero Sensor Measurements at Start** - Zero the Wireless Force Sensor at the start of data collection.
- Choice B: **Zero Sensor Now** - Works the same as a Zero button.
- Choice C: **Remove Sensor Zero Offset** - Undo. Return the Wireless Force Sensor to its previous state.
- Repeat the process for the Wireless Acceleration Sensor if needed.

### Collect Data

- In PASCO Capstone, select a display in the main window or from the **Display** palette. In the display, use the **<Select Measurement>** menu to pick a measurement to be shown.
- Select **Record** to begin collecting data.

### Troubleshooting the Wireless Force-Acceleration Sensor

- If the Wireless Force-Acceleration Sensor loses Bluetooth connection and will not reconnect, try cycling the ON button. Press and briefly **hold** the button until the status LEDs blink in sequence, and then release the button. Start the sensor in the usual way.
- If the sensor stops communicating with the computer software or tablet application, try restarting the software or application. If the problem remains, press and hold the ON button for 10 seconds and then release. Start the sensor in the usual way.
- Turn Bluetooth off and then turn it back on. Retry.

## Set Up the Hardware

### Connecting Bumper and Hook Attachments

Screw the bumper or hook attachment into the threaded hole on the front end of the sensor as shown.

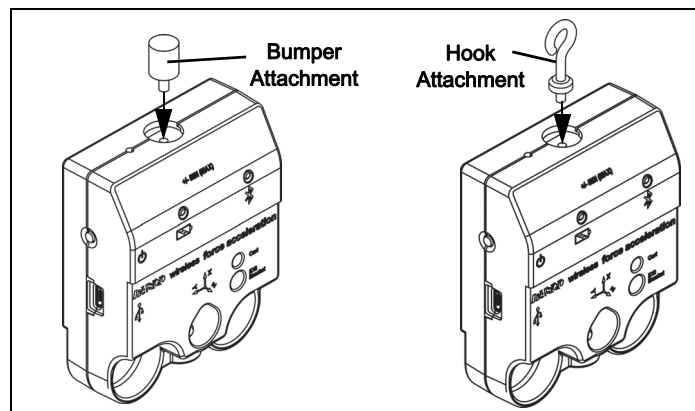

### Direction of Acceleration Sensitivity

The acceleration sensing units inside the sensor are oriented so that the lines of greatest sensitivity follow the three X-Y-Z arrows indicating the direction of acceleration.

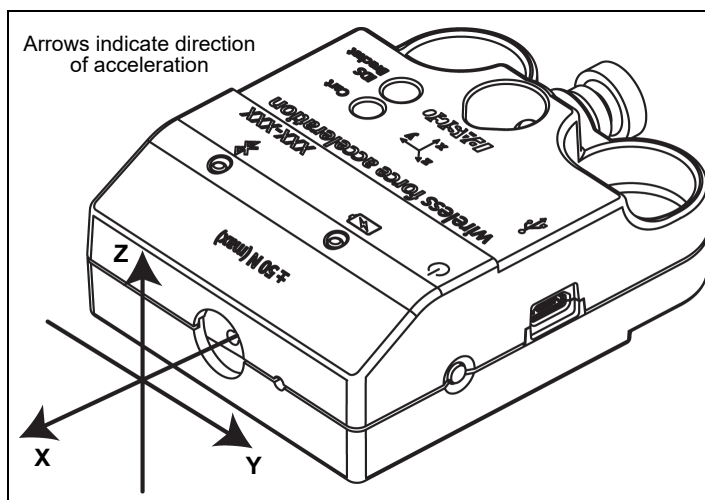

In this orientation, the X-axis direction is 'along' the axis of the sensor, the Y-axis direction is 'perpendicular' and horizontal to the axis, and the Z-axis direction is 'perpendicular' to the label on top.

### Test the Sensor's Output Using Earth's Gravity

Start the PASCO Data Collection Software. If the Force-Acceleration sensor is held so that the X-axis on the top of the sensor is vertical and pointing upward, the Acceleration X-axis reading is 1.0 g. If the sensor is



turned so the X-axis is vertical but pointing downward, the Acceleration X-axis reading is  $-1.0\text{ g}$  (where “g” represents the acceleration due to gravity).

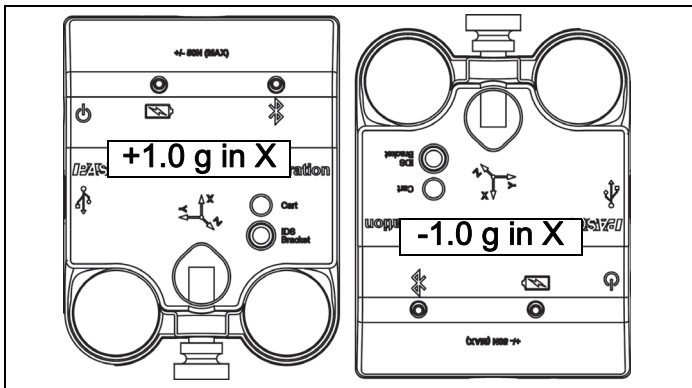

If the sensor is rotated so that the Y-axis on the top of the sensor is vertical and pointing upward, the Acceleration Y-axis reading is  $1.0\text{ g}$ . If the sensor is turned so that the Y-axis is pointing downward, the Acceleration Y-Axis reading is  $-1.0\text{ g}$ .

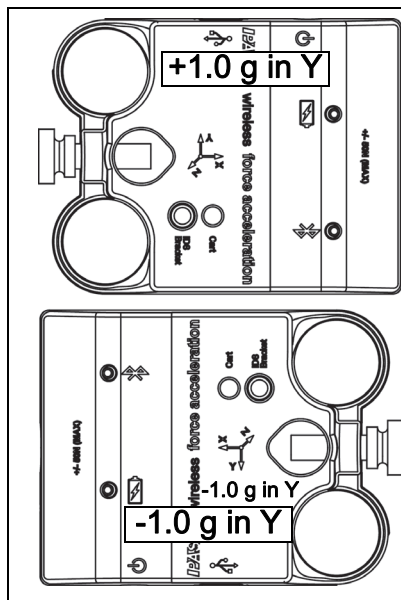

If the sensor is placed so the back is on a horizontal surface with the label facing upward, the Acceleration Z-axis reading is  $1.0\text{ g}$ . If the sensor is placed label side down so that the back is facing upward, the Acceleration Z-axis reading is  $-1.0\text{ g}$ .

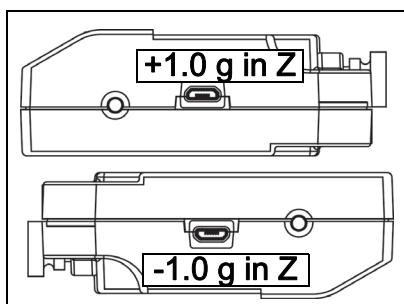

## Mounting the Sensor

### Mounting the Sensor on a Rod

Slide the sensor onto a rod and secure it with the Rod Clamp Thumbscrew as illustrated.

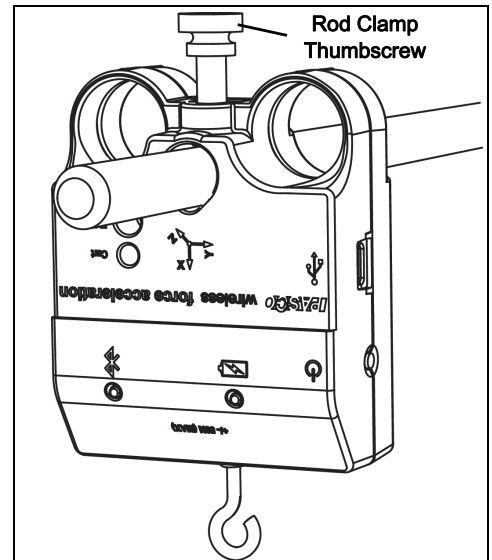

### Mounting the Sensor on a PASCO Cart

1. Insert the included Cart/Track Thumbscrew through the hole in the sensor labeled **Cart**.
2. Screw the thumbscrew into the threaded hole on the top of the PASCO cart.

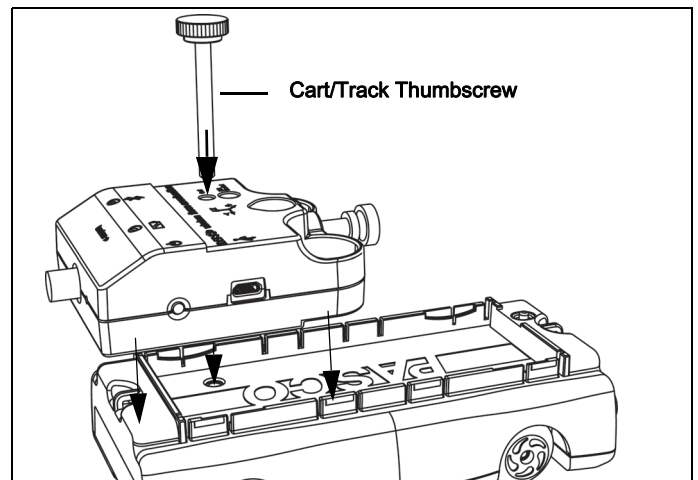

### Mounting the Sensor on an IDS Bracket

1. Insert one of the included plastic thumbscrews from the Force Accessory Bracket through the hole in the Force Accessory Bracket (PASCO part CI-6545) as shown.

2. Screw the thumbscrew into the threaded hole on the sensor labeled **IDS Bracket**

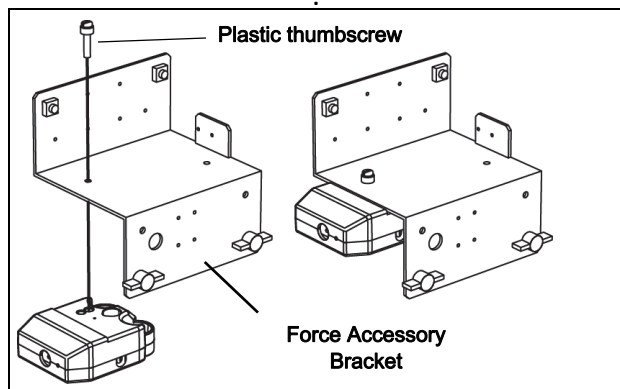

## Mounting the Sensor on a Discover Collision Bracket

1. Mount the Discover Collision Bracket (PASCO part ME-8973A) into the T-slot on a PASCO track.
2. Temporarily remove the rod clamp thumbscrew from the sensor. Use the thumbscrew on the bracket to attach the sensor to the bracket

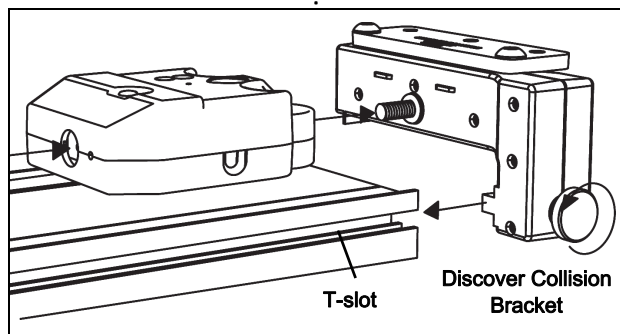

## About the Battery

The Wireless Force Acceleration Sensor's battery is partially charged at the factory. If the battery status LED blinks red, use the micro USB cable to connect the sensor to a USB port or a USB charger.

### Battery Usage

Battery life is very important to making the sensor simple and always ready to use, so all of the PASCO wireless products are designed for long battery life. For example, the sensor turns itself off after a few minutes of inactivity to conserve battery life.

The battery life between charges for the sensor varies depending on the sampling rate. The battery life ranges between eleven hours for high sample rates to more than 70 hours for low sample rates.

In typical classroom/lab use, this would translate to a battery life between charges ranging from one to four weeks or more, because full-day continuous sampling would be unusual. Even in the most extreme case with a high sample rate, the Force-Acceleration Sensor battery would support a full day of use before needing to recharge.

### Maximizing Battery Life

One of the factors that affects battery life is the storage temperature. Therefore, avoid storing the sensor in very cold or very hot environments.

## Suggested Experiments

Practically any experiment that uses a force, acceleration, or rotational motion measurement can be done with the PS-3202 Wireless Force-Acceleration Sensor. See the PASCO Web site at

[www.pasco.com/products/lab-manuals](http://www.pasco.com/products/lab-manuals)

for more information about experiments.

## Calibrating the Sensor

The sensor is factory calibrated. Further calibration is not always necessary, especially if you are measuring a change in force, acceleration, or rotational motion rather than absolute values. However, it is possible to calibrate the sensor. For detailed information, see Appendix B.

## Specifications

Item	Value
Force Range	±50 newtons (N)
Acceleration Range	up to ±16 g (1 g = 9.8 m/s <sup>2</sup> )
Angular Rotation Rate Range	up to ±2000 degrees per second
Force Resolution	0.03 N
Accuracy	0.1 N
Logging	Yes

### Accessories

- CI-6545 IDS Force Accessory Bracket
- ME-8973A Discover Collision Bracket
- ME-9884 Bumper Accessory Set
- ME-6617 Rocket Engine Test Bracket

## Technical Support

For assistance with any PASCO product, contact PASCO at:

Address: PASCO scientific  
10101 Foothills Blvd.  
Roseville, CA 95747-7100

Phone: +1 916 462 8384 (worldwide)  
8700-772-8700 (U.S.)

Web: [www.pasco.com/support](http://www.pasco.com/support)

Email: [support@pasco.com](mailto:support@pasco.com)

The Reference Guide will be updated periodically. For the latest revision of this Reference Guide, visit the PASCO Web site at

[www.pasco.com/manuals](http://www.pasco.com/manuals)

and enter the product number, PS-3202, in the text window.

## Replacement Parts

For information about possible replacement parts, contact Technical Support:

USB Cable, Micro-to-USB A  
Hook Attachment  
Bumper Attachment  
Cart/Bracket Thumbscrew

### Limited Warranty

For a description of the product warranty, see the PASCO catalog. For more information visit [www.pasco.com/legal](http://www.pasco.com/legal)

### Copyright

This PASCO scientific *Reference Guide* is copyrighted with all rights reserved. Permission is granted to non-profit educational institutions for reproduction of any part of this manual, providing the reproductions are used only in their laboratories and classrooms, and are not sold for profit. Reproduction under any other circumstances, without the written consent of PASCO scientific, is prohibited.

### Trademarks

PASCO, PASCO scientific, PASCO Capstone, PASPORT, and SPARKvue are trademarks or registered trademarks of PASCO scientific, in the United States and/or in other countries. All other brands, products, or service names are or may be trademarks or service marks of, and are used to identify, products or services of their respective owners. For more information visit [www.pasco.com/legal](http://www.pasco.com/legal).

### FCC Statement

This Class A digital device complies with part 15 of the FCC Rules. Operation is subject to the following two conditions: (1) This device may not cause harmful interference, and (2) this device must accept any interference received, including interference that may cause undesired operation.

### CE Statement

This device has been tested and found to comply with the essential requirements and other relevant provisions of the applicable EU Directives.

### Product End of Life Disposal Instructions:

This electronic product is subject to disposal and recycling regulations that vary by country and region. It is your responsibility to recycle your electronic equipment per your local environmental laws and regulations to ensure that it will be recycled in a manner that protects human health and the environment. To find out where you can drop off your waste equipment for recycling, please contact your local waste recycle/disposal service, or the place where you purchased the product.

The European Union WEEE (Waste Electronic and Electrical Equipment) symbol (to the right) and on the product or its packaging indicates that this product **must not** be disposed of in a standard waste container.



### Battery Disposal Instructions:

Batteries contain chemicals that, if released, may affect the environment and human health. Batteries should be collected separately for recycling, and recycled at a local hazardous material disposal location adhering to your country and local government regulations. To find out where you can drop off your waste battery for recycling, please contact your local waste disposal service, or the product representative.

The Lithium Polymer (Li-Poly) rechargeable battery used in this product is marked with the International symbols to indicate the need for the separate collection and recycling of batteries.



Li-Poly

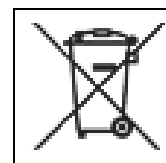



## Appendix A: Bluetooth<sup>®</sup> Compatibility SMART

Check the PASCO Web page at

[www.pasco.com/compatibility](http://www.pasco.com/compatibility)

for the latest information on Bluetooth SMART compatibility.

Platform	Bluetooth SMART Compatibility
iOS	iPad 3 and later iPhone 4S and later iPod touch 5 and later
SPARK Element	All models
Android	Android 4.3 and later
Chromebook	Chrome OS (requires PS-3500 Adapter*)
Mac OS X <sup>1</sup>	Models introduced July 2011 or later
Windows	Windows 7 and later (requires PS-3500 Adapter*)

\*The PS-3500 USB Bluetooth 4.0 Adapter, when connected to a USB port, allows up to three Bluetooth SMART devices, such as this PASCO wireless device, to connect to Windows computers, Chromebooks, and older Macintosh computers.



Note: The PS-3500 USB Bluetooth 4.0 Adapter is the only adapter we can currently recommend. Many other Bluetooth 4.0 adapters are available but this adapter has a specific design that enables in-app pairing of Bluetooth SMART sensors.

<sup>1</sup>To check the Mac computer’s Bluetooth compatibility, do the following:

- Click the  (Apple) Menu.
- Select *About This Mac*
- Click the *More Info...* button.
- Click the *System Report...* button.
- Select *Bluetooth* from the sidebar on the left, underneath *Hardware*.
- Scan down the list of information until you find “LMP Version”.
- If your Mac is equipped with Bluetooth SMART, the LMP Version will show **0x6**. (Anything lower than **0x6** means an older version of Bluetooth. Your device will need the PS-3500 USB Bluetooth 4.0 Adapter.)

<sup>1</sup>The Mac Mini and MacBook Air were updated with Bluetooth SMART support in 2011. The MacBook Pro was updated in 2012. The Mac Pro that debuted in December 2013 has Bluetooth SMART support.

**Exception:** Before you upgrade to El Capitan (Mac OS X 10.11.x), if you have a Macintosh with LMP version “0x4” that requires the PS-3500 USB Bluetooth 4.0 Adapter, please contact PASCO Technical Support for further instructions.

### What is Bluetooth SMART<sup>®</sup>?

Bluetooth SMART (also known as Bluetooth Low Energy or Version 4.0 of the Bluetooth specification) is the latest protocol of the proprietary open wireless technology standard created by telecoms vendor Ericsson in 1994. It is the power- and application-friendly version of Bluetooth that was built for the Internet of Things (IoT).

## Appendix B: Calibration

Calibration is not necessary, especially if you are measuring a change in force rather than absolute force values. However, it is possible to calibrate the sensor.

### Prepare for Calibration

Calibration will need a 1 kilogram mass, the hook attachment, and a horizontally mounted support rod to hold the sensor. The sensor will need to be “connected” with a tablet or computer, and the data collection software (for example, SPARKvue) should be running.

### Using SPARKvue Software for Calibration

See the SPARKvue Help for information about calibrating:

- In SPARKvue, select the HELP button ( ? ) in any screen, such as the Home Screen.

1. Mount the sensor on a horizontal rod. Screw the hook attachment into the sensor.

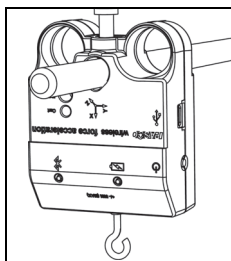

2. Click (or press) the Experiment Tools button ( ).

- The **Experiment Tools** screen opens.

3. Click **Calibrate Sensor**.

- The **Calibrate Sensor: Select Measurement** screen opens.

4. Click the **Sensor** box and click the sensor to be calibrated.

5. Click the **Calibration Type** box and click a calibration type. (For this example, click “2-point”.)

6. Click **Next**.

- The **Calibrate Sensor Enter Values** screen opens.

7. Hang the 1 kilogram mass on the hook attachment.

8. The gravitational force on the mass is pulling in the negative direction at -9.8 newtons (N). Under **Calibration Point 1**, click the **Standard Value** box and enter the known force value (that is, -9.8).

9. Under **Calibration Point 1**, click **Read From Sensor**.

- The value measured by the sensor is transferred to the **Sensor Value** box.

10. Remove the 1 kilogram mass from the hook attachment. The net force now is zero N.

11. Under **Calibration Point 2**, click the **Standard Value** box and enter the second known force value (i.e., 0).

12. Under **Calibration Point 2**, click the **Read From Sensor** box.

- The second value measured by the sensor is transferred to the **Sensor Value** box.

13. Click **OK**.

### Using PASCO Capstone for Calibration

See the PASCO Capstone Help for information about calibrating:

- In PASCO Capstone, select **PASCO Capstone Help** from the **Help** menu, or press **F1**.

1. Mount the sensor on a horizontal rod. Screw the hook attachment into the sensor.

2. Click **Calibration** ( ) in the **Tools** palette.

3. Choose the measurement you would like to calibrate now: **Force Measurement**.

4. Click **Next**.

5. Choose the type of calibration you would like to perform: **Two Standards (2 point)**.

6. Click **Next**.

7. Hang the 1 kilogram mass on the hook attachment.

8. The net force on the sensor is -9.8 N. Enter the value in the **Standard Value** text box.

9. When the **Current Value** stabilizes, click **Set Current Value to Standard Value**.

10. Click **Next**.

11. Remove the 1 kilogram mass from the hook attachment. The second force value is zero N.

12. Enter the second known force value (i.e., 0) in the **Standard Value** text box.

13. When the **Current Value** stabilizes, click **Set Current Value to Standard Value**.

14. Click **Next**.

15. Click **Finish**.

**Theory of Calibration**

One of the functions of the PASCO Data Collection Software is to take the stream of raw data from a sensor and transform it into the calibrated data that you see in the Graph, Table, and other displays. If you do not calibrate a sensor yourself, the software uses a default calibration that is loaded when the sensor is connected.

You can think of the software as taking in raw data and outputting calibrated data. When you perform a calibration, the software redefines the linear equation that transforms the raw input data into the calibrated output data. The linear function is of the form:

$$\text{Raw Input} = \text{Slope} \times \text{Calibrated Output} + \text{Offset}$$

Or:

$$\text{Calibrated Output} = (\text{Raw Input} - \text{Offset}) / \text{Slope}$$

The function can be represented graphically as a line.

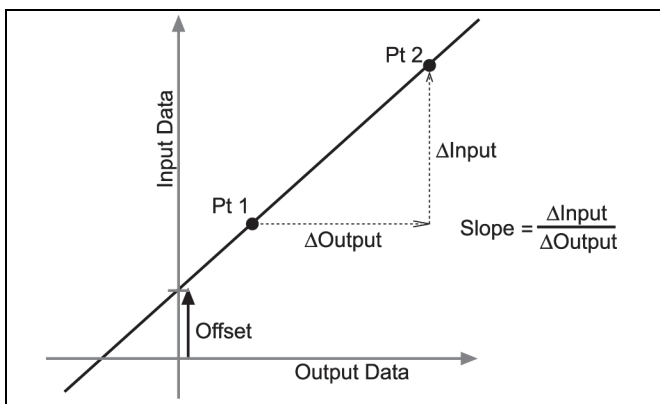

Two points, Pt 1 and Pt 2, define the line. In the two-point calibration procedure, each point is reset by associating a known standard value (for instance, the temperature of ice water) with a raw input measurement that the sensor sends out when it is in that standard. In a one-point calibration, only one of the points is reset by the user.

**Types of Calibration**

There are three types of calibration: two-point, one-point slope, and one-point offset. Any of these calibrations can be performed on a single sensor, or simultaneously on multiple similar sensors; however, for any given sensor, the software will automatically select the most typical calibration type as the default setting.

**Two-Point**

In a two-point calibration, you reset two points to define a new line. This type of calibration affects both the slope and the offset.

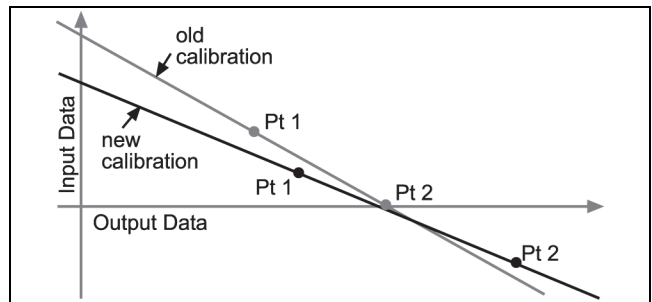

**One-Point Slope**

In a one-point slope calibration, you reset only one point. The slope of the line changes so that the line intersects the new point, while the offset (or Y-intercept) does not change.

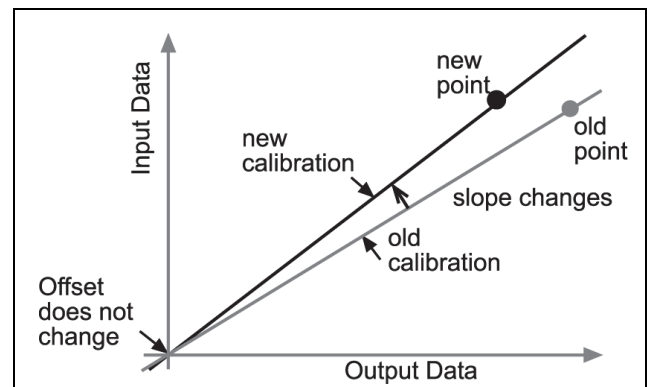

**One-Point Offset**

In a one-point offset calibration, you reset only one point. The line shifts so that it intersects the new point, but its slope does not change.

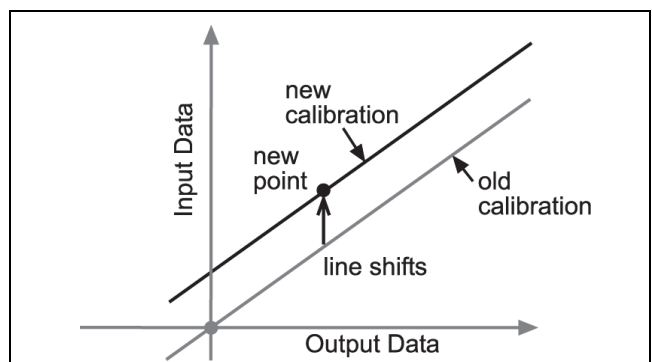

Offset calibration is usually used to make one sensor agree with another sensor. Due to normal variation among probes, a second probe might read consistently higher than the first probe. Normally this difference would be insignificant; however, an offset calibration can be used to bring the sensors into closer alignment.