

Teaching Manual

Ver. 1.0.1

Cod. 115.2025



CONATEX-DIDACTIC

Lehrmittel GmbH, Zinzingerstr. 11 - 66117 Saarbrücken

Tel. +49 6849-99296-0 Fax +49 6849 9929626

www.conatex.com



ELECTROMAGNETIC SCALE

This device is formed by a balance, that has an arm that ends with a coil *s* where direct current, with a maximum intensity equal to 10 A, can circulate.

The supply voltage must be applied to the clamps A and B. When there aren't the electromagnetic forces, the arms balancing is obtained acting on the sliding cursor C for a coarse adjustment, and on the thumbscrew G, for a fine adjustment (fig. 1).

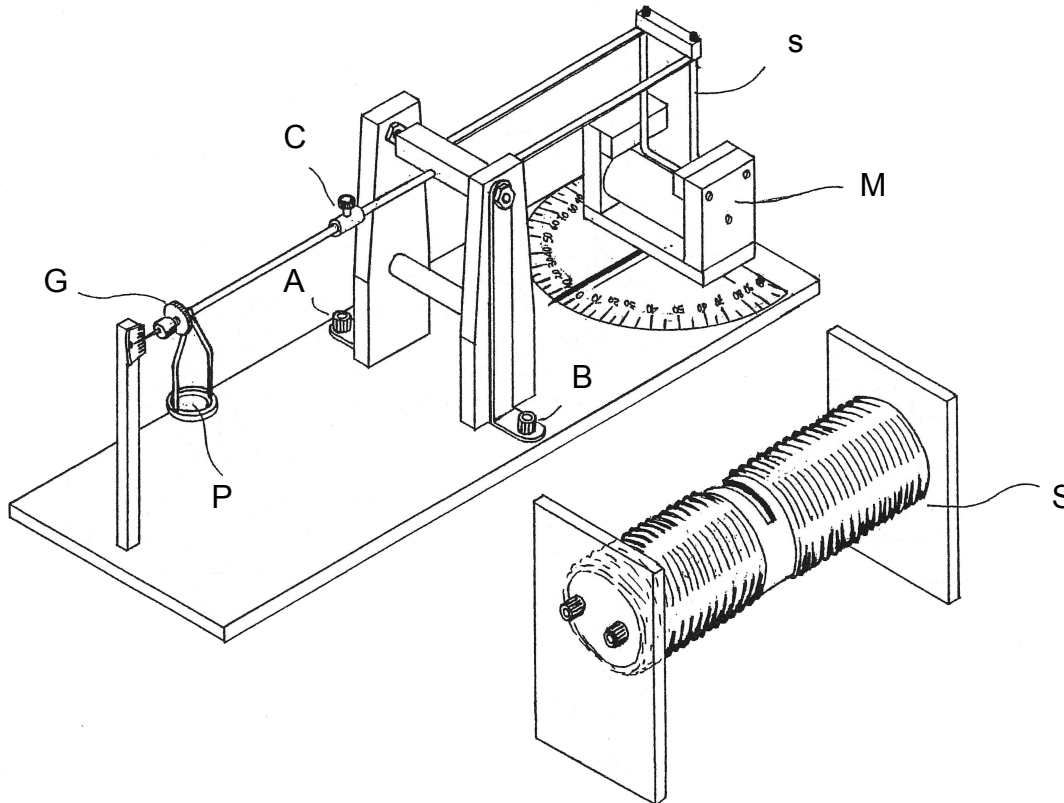

Fig. 1

The balance has a set of weights with the submultiples of the gram. We suggest to use always the proper tweezers when you put the weights on the pan P.

There are two possibilities:

- the coil *s* can be placed between the polar expansion of a permanent magnet M, where the north pole is red;
- the coil can be placed inside a great solenoid S, where the current that circulates can have a maximum intensity equal to 10 A.

Let's examine the two cases separately.

1) Coil in the permanent magnetic field

When a linear conductor with a length *l*, that is crossed by a direct current with an intensity *i*, is in a magnetic field with an induction *B*, that is perpendicular to the flow lines of the field, is subject to a force that has a value of

$$F = B \cdot i \cdot l$$

and it has a way and a direction that are assigned by the left-hand rule (fig. 2).

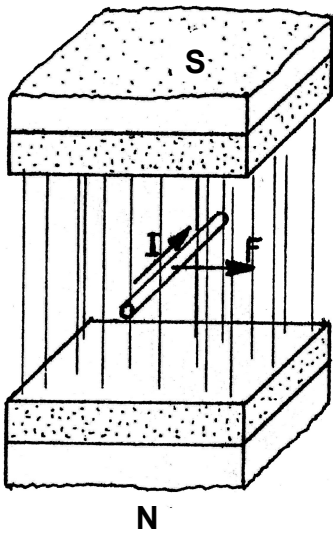

Fig. 2

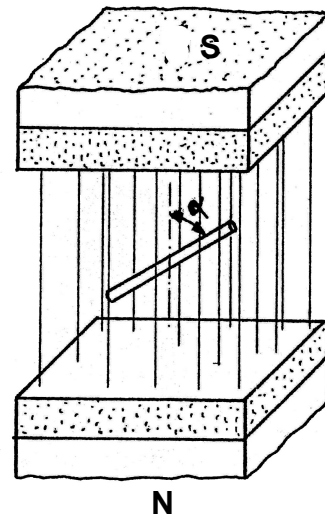
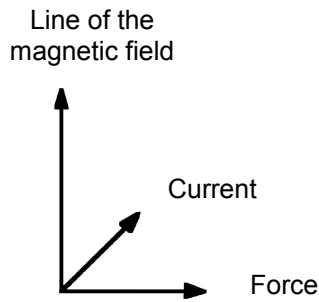

Fig. 3

If the conductor forms an angle α with the direction of the flow lines of the magnetic field, the force intensity varies with $\text{sen}\alpha$.

To be more precise (fig. 3),

$$F = B \cdot i \cdot l \cdot \text{sen } \alpha$$

With the electromagnetic balance, it is possible to verify this relation. Indeed, provided that the values of B , i and l are the same, we find that if $\alpha = 0^\circ$ $F = 0$, while if $\alpha = 90^\circ$ F is at its maximum value. So we can fill in a table and report in a diagram the values we have obtained.

In order to measure the force that acts on the horizontal part of the coil, it is necessary to arrange all the things as it is shown in picture n. 4, i.e. connecting the positive polarity of the power supply (We recommend a power supply for at least 5 A being careful not to exceed 10 A, the maximum power supply tolerated by the equipment) to the red clamp B. In this way, the electromagnetic force that acts on the coil is attractive, and it can be balanced with the weights placed on the pan.

With this experiment, it is possible to know the value of the magnetic induction B . Indeed, it is enough to measure with an ammeter the intensity i of the current and with a callipers the length l of the horizontal part of the coil s (fig. 5).

The result is

$$B = \frac{F}{i \cdot l \cdot \text{sen}\alpha}$$

where	>	F	=	Newton
	>	i	=	Ampère
	>	l	=	metre
	>	B	=	tesla

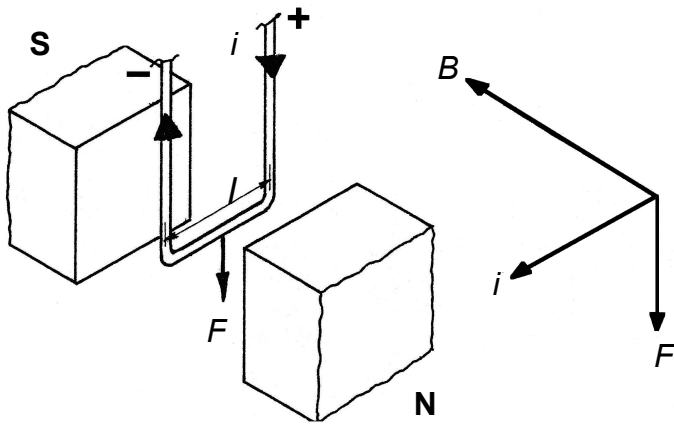

Fig. 4

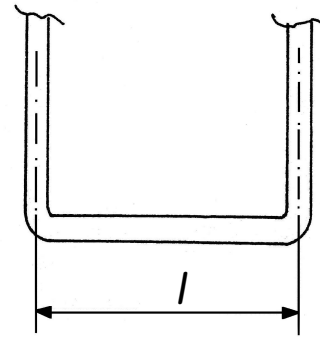

Fig. 5

2) Coil in the magnetic field of a solenoid

The magnetic field inside a solenoid formed by N coils, that is crossed by a current i' and distributed on a length l' , has an induction B with a value equal to

$$B = \mu_0 \frac{N \cdot i'}{l'}$$

where $\mu_0 = 4\pi \cdot 10^{-7}$ H/m and its flow lines, inside the solenoid, are parallel to the axis and they have the position shown in figure 6.

Remove the permanent magnet from its housing and then arrange the elements in the way shown in figure 7. After you have estimated the number of coils and their length, as in the previous case, pay attention to the fact that the electromagnetic force is attractive, so that you can measure it.

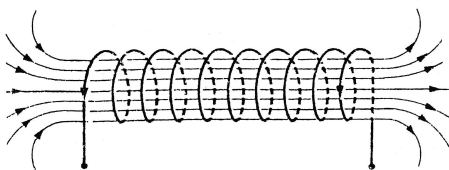

Fig. 6

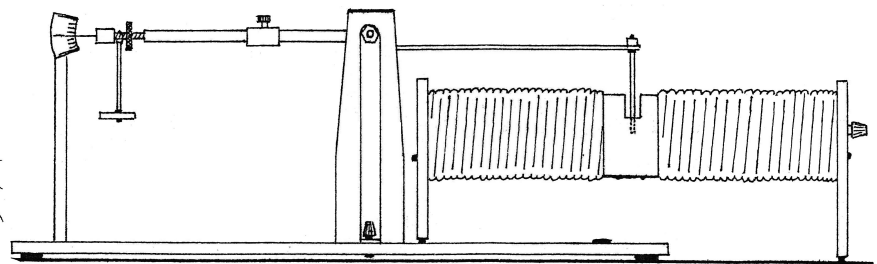

Fig. 7

NOTICE:

Any difference between the features of the parts included in the kit and those of the above pictures is due to technological updating.