

Renewable Energy Science Education Kit Assembly Guide



Battery operation instructions:

1. The removing and inserting of batteries is to be conducted by the adults only. Unscrew the screw holding the battery pack's cover in place using a screw driver. Once the screw is removed open the battery pack and take out the batteries using your fingers. Do not use a metal object. When inserting the batteries make sure that you are doing so with the correct polarity (the positive end of the battery must match up with the "+" and the negative end of the battery must match up with the "-" indicated on the battery pack), close the battery pack and secure its cover by tightening the screw with a screw driver.
2. Non-rechargeable batteries are not to be recharged.
3. Different types of batteries such as rechargeable, alkaline and standard batteries or new and used batteries are not to be mixed and should be used separately.
4. The battery pack cables are not to be inserted into an AC socket.
5. The supply terminals of the battery pack are not to be short-circuited.
6. The two spare red & black cables are not to be inserted into an AC socket.
7. Exhausted batteries are to be removed from the battery pack.

Warning

To avoid the risk of property damage, serious injury or death:

This kit should only be used by persons 14 years old and up, and only under the supervision of adults who have familiarized themselves with the safety measures described in the kit. Keep small children and animals away, as it contains small parts that could be swallowed. Read the instructions before use and have them ready for reference.

Renewable Energy Education Set

ASSEMBLY GUIDE

What you need: ● RESEK ● AA batteries=2 Units ● Water=100ml ● Scissors

IMPORTANT: Use common sense when connecting the parts described in this guide. Improper connections can cause failure and permanent damage to your equipment.

Experiment 1: Use a Solar Panel to Power the LED Module

Connect the cables to the solar cell/panel and circuit board to power LED module as shown. Make sure black and red cables are used with the red and black terminals respectively.

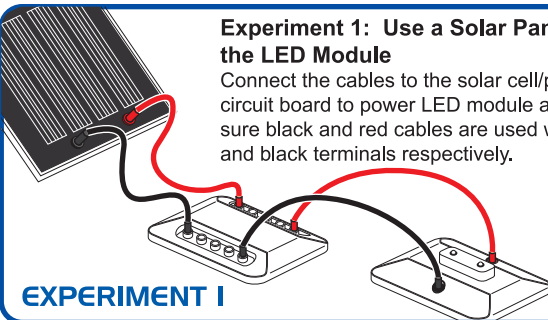

EXPERIMENT 1

Experiment 2: Use a Solar Panel to Power the Small Fan/Wheel Motor Module

1. Assembly of the small electric fan:
Connect small round white adapter to the motor axis. Connect the fan blade to the adapter.
2. Assembly of the car wheel:
Firmly connect the other (tapered) white adapter to the motor axis. Attach the small wheel to the adapter.

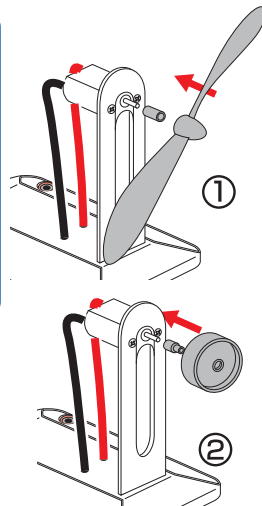

EXPERIMENT 2

3. Connect the solar panel to the circuit board then to the motor base as shown. The fan may need to be flicked with your finger to start.

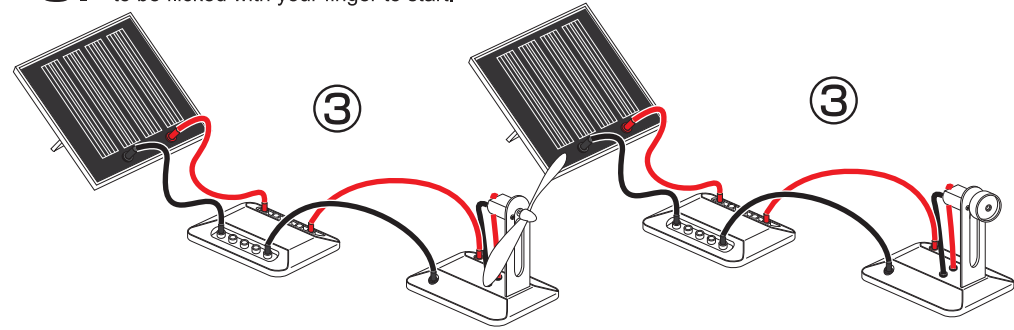

Experiment 3: Preparation of the Electrolyzer Module and Solar Powered Hydrogen Production

1. Insert the electrolyzer, terminals on top, into the slot on the base. Cut 2 x 4cm length pieces of rubber tube and insert a black pin into the end of one tube. Place the tube with the black pin into the top pin on the hydrogen side (with black terminal). Place the other tube firmly onto the top input nozzle on the oxygen side.
2. Fill the syringe with DISTILLED water. On the red oxygen side of the electrolyzer, connect the syringe to the uncapped tube. Fill the electrolyzer until water begins to flow out of the tube. Attach a red plug to the Oxygen side tube. Let settle for 3 min.
3. Attach the round cylinders to the cylinder base by pressing downward into round slots and twisting into place. Then add water up to the "0" line.
4. Cut out a 20cm length tube. Place it through the holes on the white clincher, with the clincher 4 cm from the end of the tube.
5. Place inner containers into outer cylinders minding that the gaps are not blocked by inner plastic rims. Make sure the water is still level to the "0" line. If not, remove some water with the syringe so that water level is at "0" line. Connect the tubings to the top nozzles on the inner containers. If the tubing is connected to the inner cylinders last there will be no air trapped inside the inner containers.
6. Connect the other end of the tube to the bottom end of the black hydrogen side of the electrolyzer. Connect the other end of the tube to the bottom end of the red oxygen side of the electrolyzer.
7. Connect the electrolyzer to the solar panel using the corresponding cables and expose to direct sunlight. (Important: make sure connections are correct or permanent damage can occur. Make sure the clincher is OPEN.)

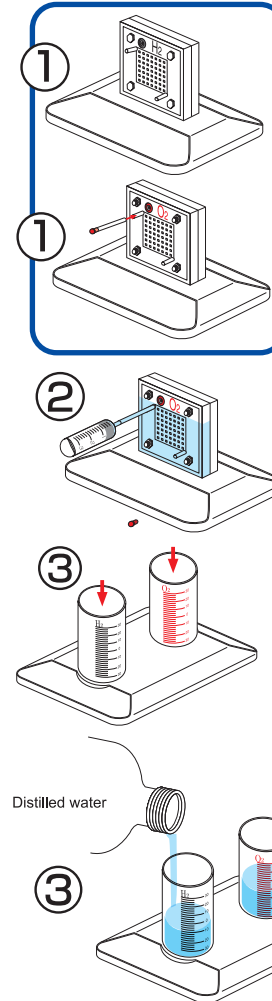

EXPERIMENT 3

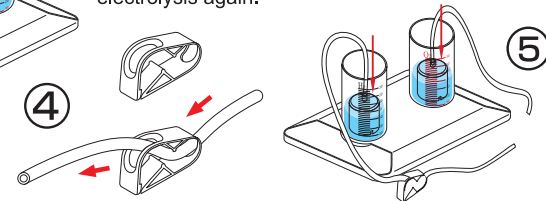

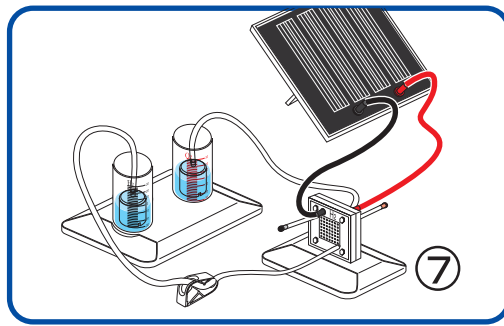
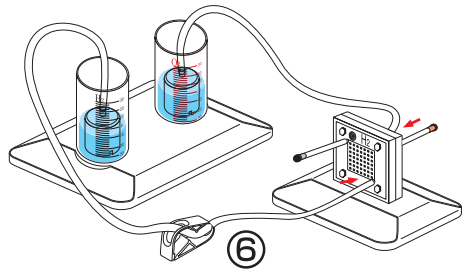

USING FUEL CELLS TO CONVERT HYDROGEN TO ELECTRICITY

Preparation of the Fuel Cell System

Insert the fuel cell into the base with the red terminal on the same side as the red terminals on the base. Connect a green purging valve to one end of a 2cm tube and the other end to the upper nozzle on the hydrogen side of the fuel cell.

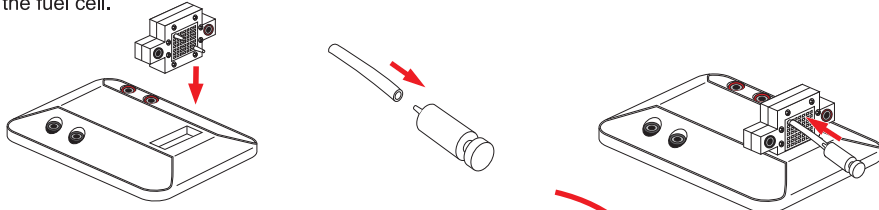

Clench the tube connected to the electrolyzer and hydrogen cylinder so that none of the hydrogen in the cylinder from the last experiment can escape. Next disconnect the tube from the electrolyzer and connect it to the lower nozzle on the fuel cell.



Experiment 4: Using a PEM Fuel Cell to Power the LED Module

Connect the fuel cell to the fuel cell base using the red and black wires. Make sure to connect the black wire with the black terminals and red with red terminals. Now connect the LED module to the base in the same manner.

You should see the LED lights begin flashing. If not, purge a very small amount out of the valve to allow some of the gas to move into the fuel cell. As the LED light consumes electricity the fuel cell will consume hydrogen from the cylinder and you will see the water level reflect the changes in amount of gases consumed.

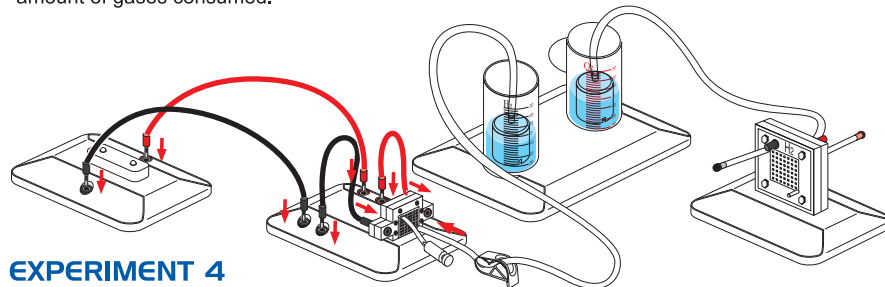

EXPERIMENT 4

Experiment 5: Using a PEM Fuel Cell to Power the Small Electric Fan Module

Repeat the hydrogen production and fuel cell preparation steps. Next, connect the small fan/wheel motor base to the fuel cell base to generate power to the motor.

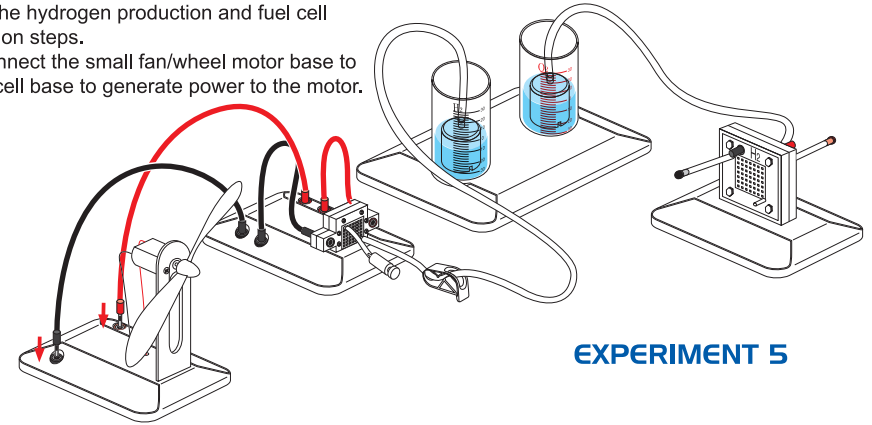

EXPERIMENT 5

Experiment 6: Using a PEM Fuel Cell to Power the Small Car Wheel Module

Repeat the hydrogen production and fuel cell preparation steps. Next, connect the small fan/wheel motor base to the fuel cell base to generate power to the motor.

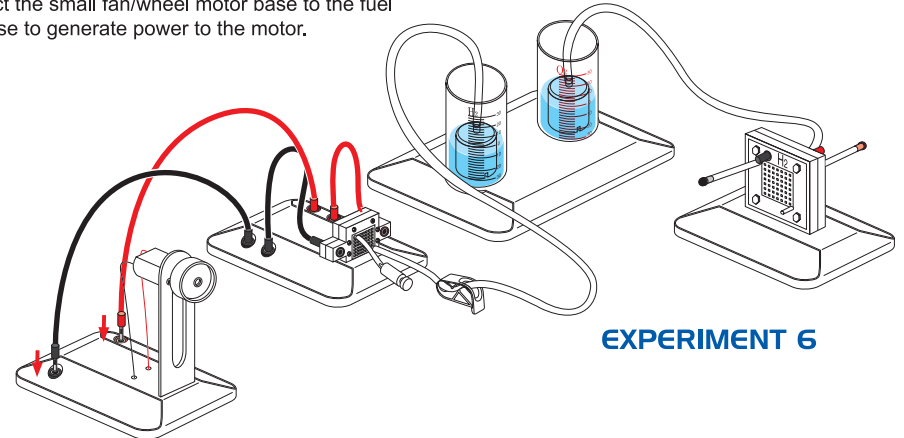

EXPERIMENT 6

Experiment 7: Using a PEM Fuel Cell to Power the Small Fan/Wheel Motor Module and the LED Module in Parallel

Repeat the hydrogen production and fuel cell preparation steps. Next, connect the small fan/wheel motor base and the LED module base to the circuit board. Then connect the circuit board to the fuel cell module base to generate power to both modules in parallel.

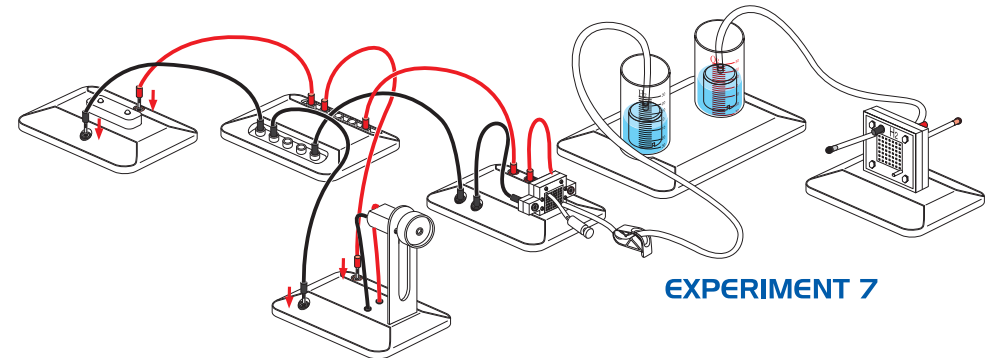

EXPERIMENT 7

DISCOVERING WIND ENERGY Assembly of the Wind Turbine

Please refer to the Wind Energy Education Kit Assembly Instructions included in your RESEK for reference in assembling the Wind Turbine.

Below table indicates expected RPM speed, current, voltage, and power when placing the WindPitch in constant windspeed of 10mph when connected to load of 50 Ohms. This level of resistance may be applied using common potentiometer (not provided) or Horizon's variable resistor module.

WindPitch Technical Specifications:

| Blade Type | No. of Blade | Wind Speed (mph) | Load (Ohm) | Output Voltage (V) | Output Current (mA) | Output Power (W) | Rotor Speed (RPM) |
|------------|--------------|------------------|------------|--------------------|---------------------|------------------|-------------------|
| Blade A | 3 | 10 | 50 | 1.15 | 28 | 0.03 | 400 |
| Blade B | 3 | 10 | 50 | 1.35 | 30 | 0.04 | 490 |
| Blade C | 3 | 10 | 50 | 2.50 | 50 | 0.125 | 705 |

Experiment 8: Using a Wind Turbine to Power the LED Module

Power the LED module by attaching the wind turbine's cables to their respective slots on the LED module base. Position turbine to directly face the direction of wind source.

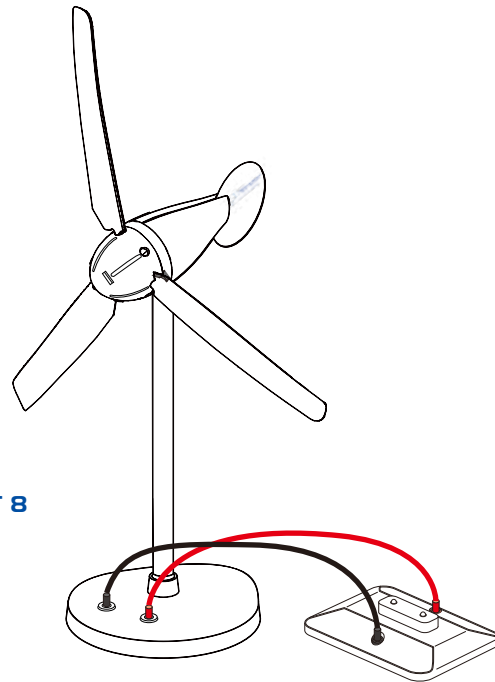

EXPERIMENT 8

Experiment 9: Preparation of the Electrolyzer Module and Wind Powered Hydrogen Production

Connect the red and black cables to the corresponding terminals located on the wind turbine and reversible fuel cell. For best results using the WindPitch to generate hydrogen using the included reversible fuel cell, setup the wind turbine hub with 3 profiled blades marked C supplied with the kit.

Set the blade pitch to 6 degrees. Make sure that the wind turbine is generating AT LEAST 2.5 volts. If not, move the wind turbine closer to the fan until it does. The wind turbine is sensitive to this setting at high wind speeds.

Allow the table fan and wind turbine to run for about 60 minutes on high wind speed setting to generate sufficient amounts of hydrogen and oxygen gases that are stored in the water/gas tanks.

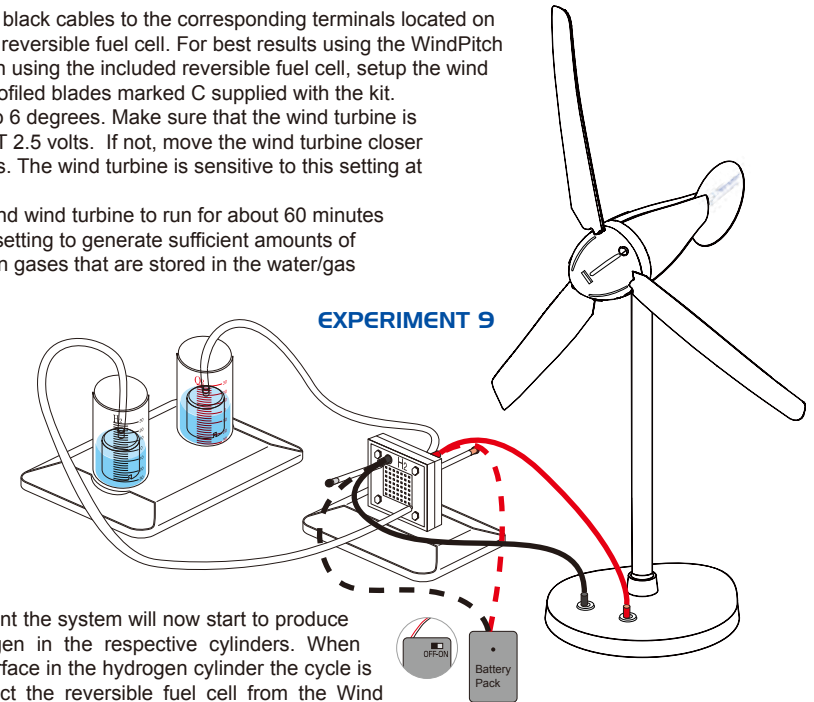

If the wind is sufficient the system will now start to produce hydrogen and oxygen in the respective cylinders. When bubbles begin to surface in the hydrogen cylinder the cycle is complete. Disconnect the reversible fuel cell from the Wind Turbine.

Procedure for repeated gas production: Disconnect the small plugs from the tubes connected to the nozzles on the reversible fuel cell. This will allow water into the inner cylinders to replace the gasses and reset water levels to "0" line. Re-insert the plugs into the tubes and repeat electrolysis again.

Note: You may also use the battery pack to perform electrolysis (In the case of no wind source)

Experiment 10 (alternative): Using the Battery Pack to Perform Electrolysis (in the case of no sun or wind)

Please remove the screw from cover of battery box using a screw driver.

Push and slide the cover and open the battery box.

Try NOT to touch the cables when you open the cover.

Place two AA batteries as indicated.

Push and slide the battery box cover to closed position and screw tightly into place using screw driver.

- ※ Make sure the switch on the battery box is in the "off" position before you place the batteries into the box.
- ※ **WARNING: If the cable is short circuited the batteries inside could become hot and potentially cause burns, melting of parts, or create risk of fire.**
- ※ *Note: Battery's energy may be consumed after 4-5 times of use.*

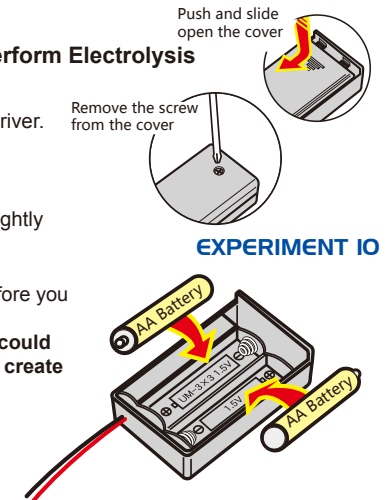

RENEWABLE ENERGY SCIENCE EDUCATION KIT

TECHNICAL SUPPORT

1. The water levels do not drop when the gas outlet tubes on both sides of the fuel cell are unplugged.

Solution:

Check whether the holes on the wall of the inner container are blocked. If so, turn the inner container until water enters the holes and fills up the inner container.

2. The electrolyzer does not produce hydrogen and/or oxygen.

Solution 1:

Check whether the wires are appropriately connected, and whether there are any loose connections. The fuel cell could be completely destroyed if the red wire of the battery pack is connected to the black jack of the fuel cell.

Solution 2:

Replace the old batteries with new one in the battery pack.

3. The load cannot work while there is hydrogen left in the inner container.

Solution:

Push the green purging valve to release tiny amount of hydrogen. You can then observe the load working well again.

4. The water electrolysis process slows down.

Solution:

Inject water to the oxygen side of the fuel cell by using the syringe and wait for about 3 minutes before using the electrolyzer again.

5. No hydrogen is produced using the windturbine outdoors.

Solution:

If the wind speed is not sufficient electricity will not be created. Use a common desk fan with faster wind speed to perform the electrolysis using the electrolyzer, or conduct the experiment under stronger wind conditions.

6. If the fuel cell and/or electrolyzer becomes flooded with water

Solution 1:

Use the syringe to clear the water out of the fuel cell.

Solution 2:

Use the hair drier to blow hot air towards the fuel cell and the nozzles on each side. Make sure you blow warm air towards the fuel cell.

7. The fuel cell can not generate electricity while there is hydrogen still left in the hydrogen container.

Solution 1:

Push the purging valve to release remaining amounts of hydrogen.

Solution 2:

Use the syringe to clear the water out of the fuel cell.

Wind Energy Education Kit Assembly Guide



Warning

To avoid the risk of property damage, serious injury or death:
This kit should only be used by persons 14 years old and up, and only under the supervision of adults who have familiarized themselves with the safety measures described in the kit. Keep small children and animals away, as it contains small parts that could be swallowed. Read the instructions before use and have them ready for reference.

Wind Energy Education Kit ASSEMBLY GUIDE

Refer to the following assembly drawing and the Part List reference numbers for assembly.

I. Main Body Assembly

Part List

1. Left Housing
2. Right Housing
3. Generator
4. Printed Circuit Board Assembly
5. Polypropylene Vane
6. Screw, M2.5 x 5 mm
7. Hex Nut, M2.5
8. Rotor Base
9. Molded Profile Blade
10. Profile Blade Holder
11. Blade Assembly Lock
12. Polypropylene Sheet Blade
13. Aluminium Post
14. Screw, M3 x 2 mm
15. Output Wire
16. Support Base Assembly
17. Output Socket
18. Post Secure Pin

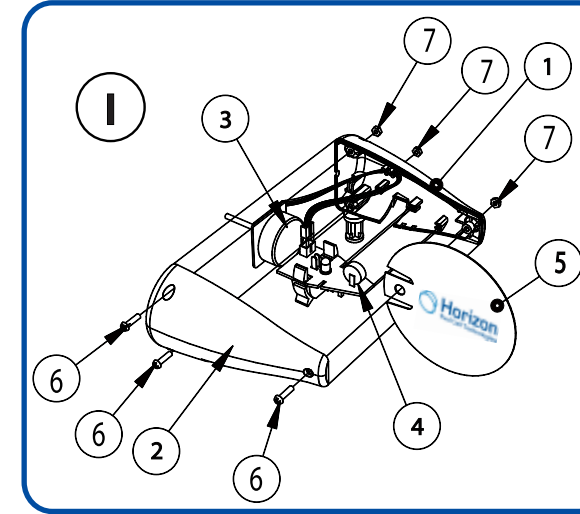

II. Blade Unit Assembly

Profiled Blade:

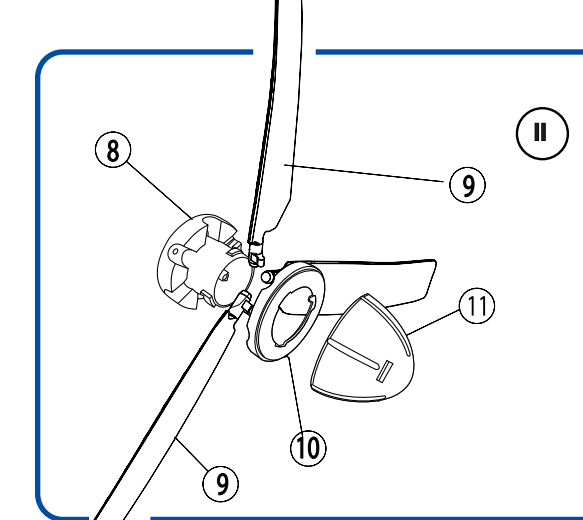

Place the Rotor Base (8) onto the flat surface of a table. Install 3 pcs of the same type of profiled blades (marked B or C) evenly on the Rotor Base. Pay attention that the snap joint must be pushed into the Rotor Base. Place the Blade Holder (10) on top of the installed blades. Pay attention to the direction of the Blade Holder. Screw the Blade Assembly Lock (11) onto the top of the Blade Assembly.

***Do not over tighten the Blade Assembly Lock otherwise you may have a difficult time in unlocking the Blade Unit Assembly.**

Sheet Blade:

Place the Rotor Base (8) onto the flat surface of a table. Install 3 pcs of the same type of Sheet blades (12) (marked A) evenly on the Rotor Base. Pay attention that the snap joint must be pushed into the Rotor Base. Place the Blade Holder (10) on top of the installed blades. Pay attention to the direction of the Blade Holder. Screw the Blade Assembly Lock (11) onto the top of the Blade Assembly.

***Do not over tighten the Blade Assembly Lock otherwise you may have a difficult time in unlocking the Blade Unit Assembly.**

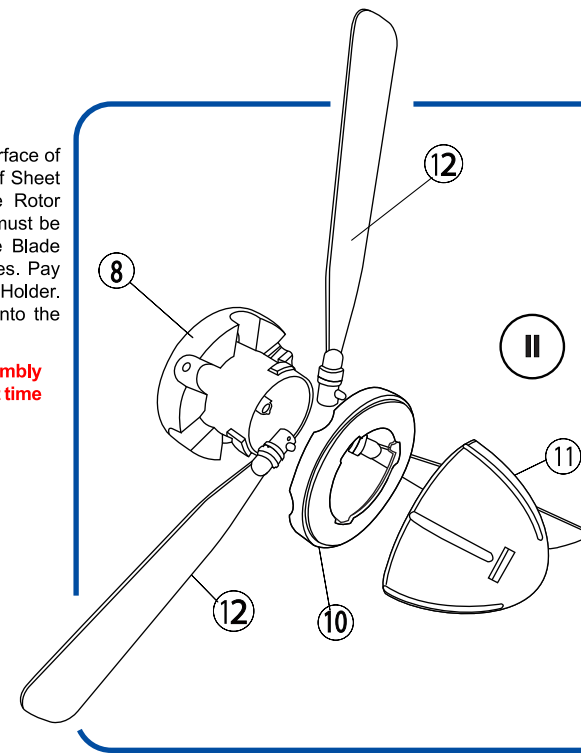

III. Blade Unit Installation

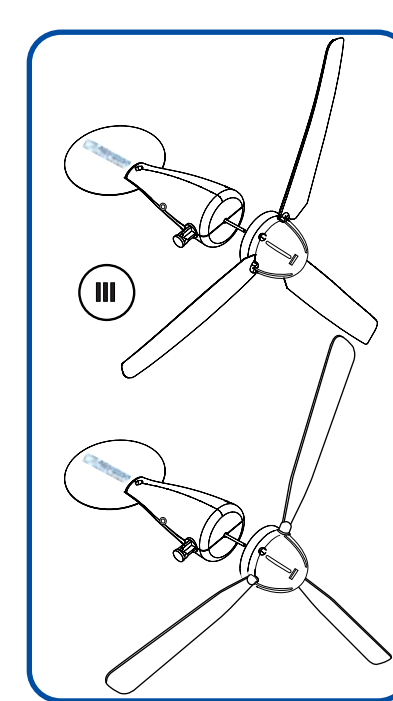

Push the rotor shaft to the rotor base to ensure the main body and rotor head are properly connected. Make sure you press the Blade Unit all the way onto the shaft. Check that the Blade Unit is securely connected onto the shaft of the turbine. If not properly installed, the rotor may not effectively turn the rotor shaft and will not generate electricity.

IV. Post and Support Base Assembly

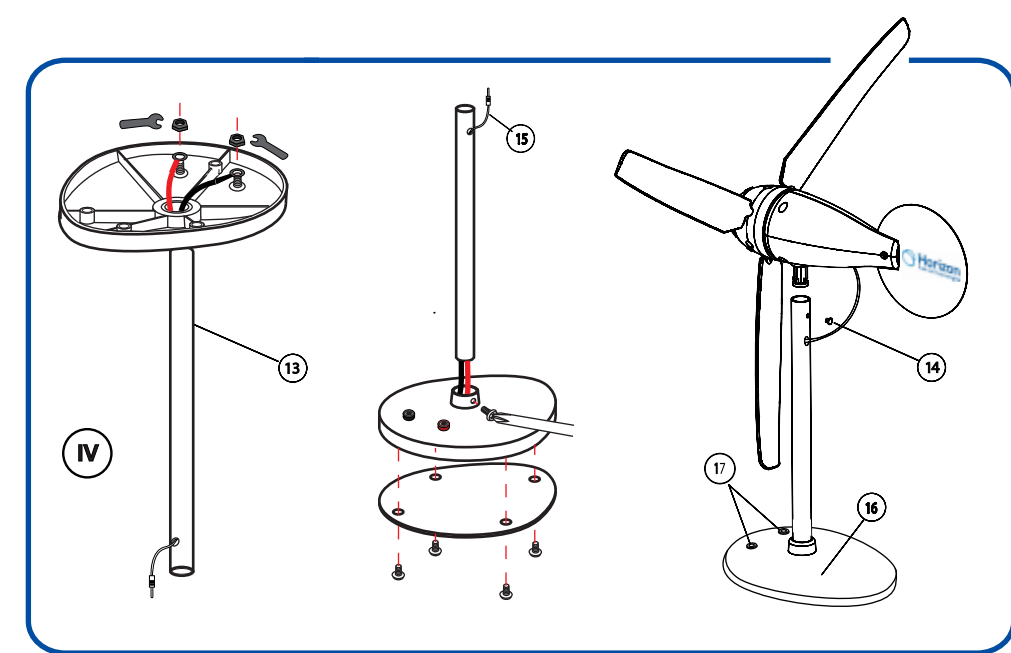

Enable Yawing:

Yaw - To turn about on vertical axis. To move unsteadily or weave.
The wire connector hole should be located on the **same** side of the tube (13) with two vertically aligned holes. Insert the Aluminium Tube into the Support Base. Install the Body Assembly onto the top of the Aluminium Tube and secure it with the screw (14). The screw should be secured from the **back** side of the wind turbine body into the groove of the plastic stud to **enable** yawing and movement of the turbine body.

Disable Yawing (Not shown in the Assembly Drawing):

The wire connector hole should be located on the **opposite** side of the tube (13) with two vertically aligned holes. Insert the Aluminium Tube into the Support Base. Install the Body Assembly onto the top of the Aluminium Tube and secure it with the screw (14). The screw should be secured from the **front** side of the wind turbine body through the hole on aluminum tube into the solid plastic stud to **disable** yawing and movement of the turbine body.

V. Blade Pitch Setting

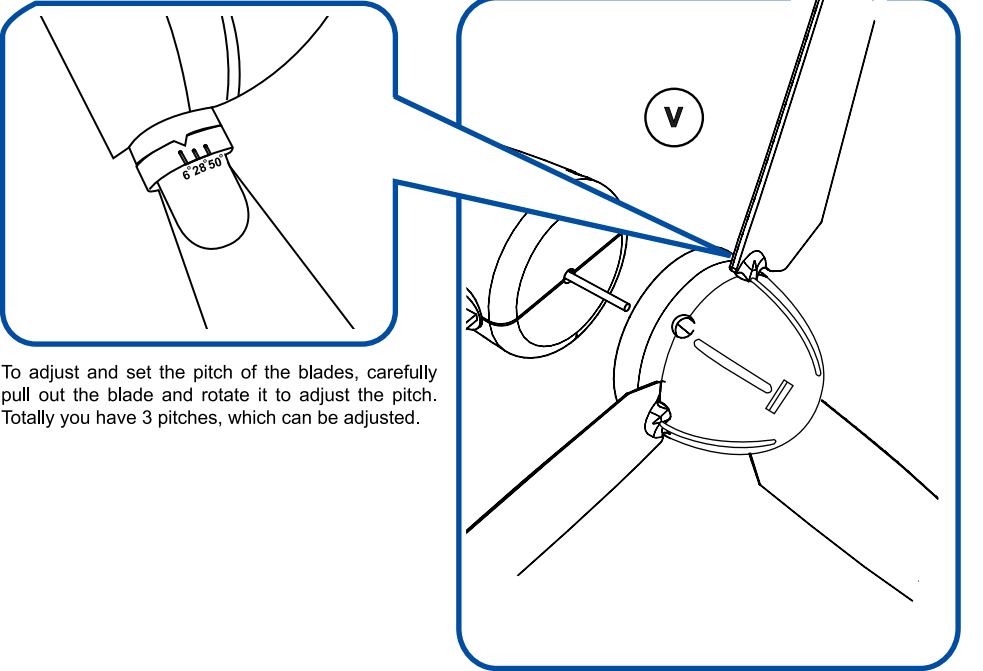

To adjust and set the pitch of the blades, carefully pull out the blade and rotate it to adjust the pitch. Totally you have 3 pitches, which can be adjusted.

The Pitch Angle

The blades themselves have different set angles at different sections to enhance the performance. This setting is to compensate the rotating speed of the blade at different radius (sections) so that the blades will not stall at a particular section. You may have to learn more about a parameter called Tip Speed Ratio to understand more thoroughly. This Ratio defines how fast the turbine is rotating under a wind speed environment. By changing the blade pitch, this ratio will be changed. Thus the output power of the turbine is changed. Each adjustment represents a change of 22 degrees. Therefore, the pitch is allowed to be adjusted from 6 to 50 degrees.

At smaller pitch value settings, the start up wind speed has to be very high. Maximum output power occurs at a pitch of around 28 degrees. The start up wind speed is higher at a lower pitch setting. If the wind speed is low you should increase the pitch so that you can achieve a higher power output.

Wind Kit Technical Specifications:

| Blade Type | No. of Blade | Wind Speed (mph) | Load (Ohm) | Output Voltage (V) | Output Current (mA) | Output Power (W) | Rotor Speed (RPM) |
|------------|--------------|------------------|------------|--------------------|---------------------|------------------|-------------------|
| Blade A | 3 | 10 | 50 | 1.15 | 28 | 0.03 | 400 |
| Blade B | 3 | 10 | 50 | 1.35 | 30 | 0.04 | 490 |
| Blade C | 3 | 10 | 50 | 2.50 | 50 | 0.125 | 705 |

Different Blade Types

There are three types of profiled blades included in the Wind Energy kit. After you obtain the maximum output power with a particular blade type, you may replace with another type of profiled blade and evaluate its performance in comparison.

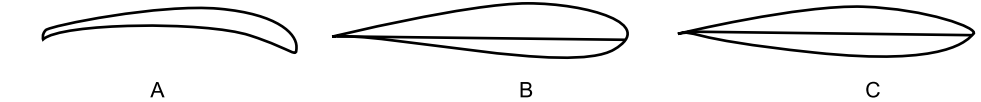

The difference between these 3 profiles is the amount of material on the side facing the wind. All of them have a much more curved profile on the Rear side (down wind side) to increase the distance for the wind to travel. The Blade Type no. is engraved on the root part of the Blade for your reference.

Changing the Number of Blades

There are 6 positions for the installation of blades and it is possible to install up to 6 blades. However, with 6 blades installed the pitch adjustment is limited. It is recommended to experiment with numbers of 2, 3, 4, and 6 blades installed under various wind speeds and blade pitch settings.

If you have enough wind try reducing to 2 blades as you may get a little more power than using 3 blades. More blades installed will allow the turbine to start rotating more quickly under low wind conditions.

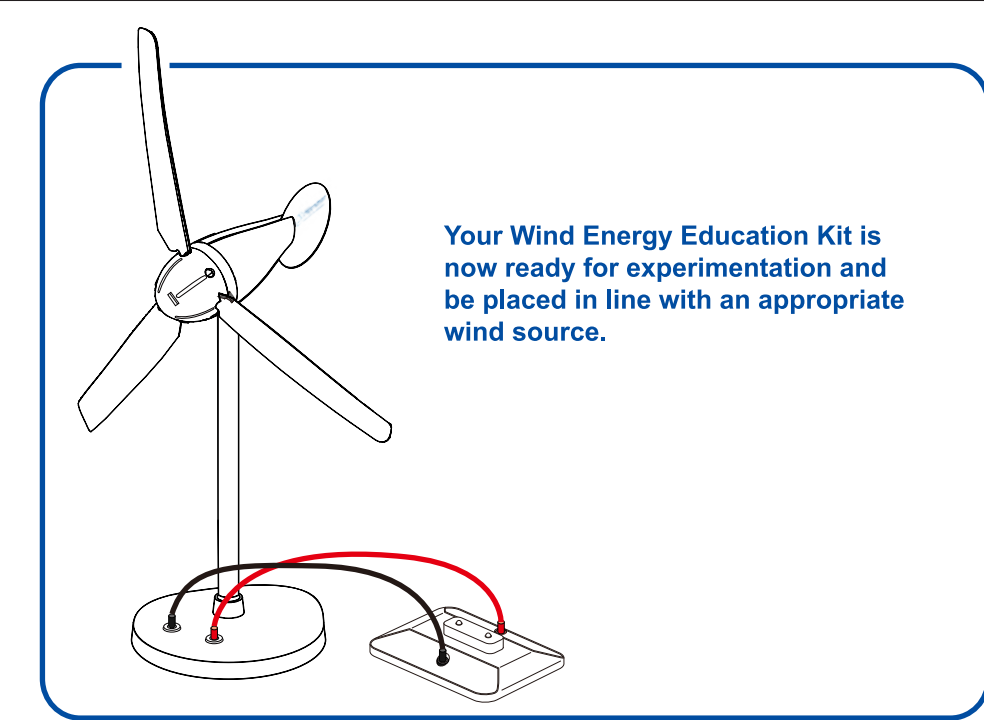
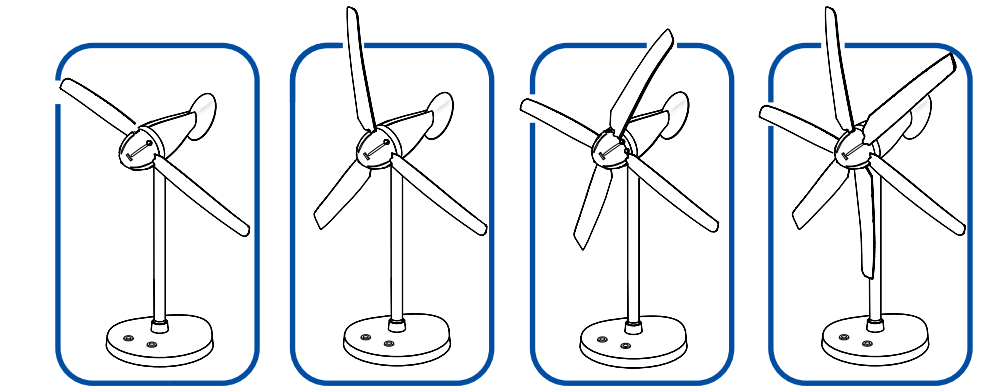

Most commonly a floor or basic desk fan is the source of wind used for experimentation with the Wind Kit. A larger fan allows you to test the performance of the turbine at higher wind speeds. You can switch the fan to a lower setting or increase the distance between the fan and the turbine to achieve low wind speeds. It is difficult to achieve high wind speeds with a small fan. A fan of 16" diameter is suitable for doing most wind power experiments. For optimum performance, align the centre of the fan with that of the nacelle of the turbine. Therefore, it will be better if the height of the fan is adjustable.

Wind from a natural source is never steady. Therefore, the output power of the turbine is always varying. This may lead to uncertainty in taking readings and measurements in the experiments. In order to reduce the variation of wind speed due to turbulence, operate the setup at the middle of a hall or use a wind tunnel. The wind speed will be more stable under these conditions.

With the included LED Module you can demonstrate the output power created by the Wind Kit and use this power to illuminate the LED Lights on the Module. You can use the Renewable Energy Monitor FCJJ-24 (not provided) to measure the LED.

To connect the LED Module simply connect the red and black cable leads from the module to the red and black input jacks on the Support Base. It is highly recommended that you connect the module while the Wind turbine is not in motion and has not been placed in source of wind. Take care to arrange the wires so that they will not be tangled by the rotating blades. Use REM to measure how much voltage is being produced under your experimental conditions.

This LED Module is intended as a basic demonstration device. To perform much more detailed experiments and explore the full educational value of your Wind Kit we recommend purchasing the Horizon Renewable Energy Monitor. With the device and in combination with Horizon's PEM electrolyzers you can perform a multitude of experiments including:

Take your Wind Kit experimentation to the next level !

Listed below are additional wind experiments that can be performed with the Wind Kit wind turbine using a multimeter or with Horizon's Renewable Energy Monitor Lab and your computer.

- **Using Different Blade Shapes Create Power**
This experiment demonstrates how blades with different curvatures produce different degrees of power output. Wind turbine blades are shaped like airplane wings, and one size does not fit all requirements. You will measure and understand how using the right blade shape can produce optimum power for different wind conditions.
- **How Many Blades Are Best? 1, 2, 3, 4...**
Using the right number of blades for a given wind condition is important in extracting the maximum electrical power from a wind turbine. You will measure and understand the choices between the numbers of blades that are necessary to produce best results.
- **Adjusting Blade Pitch for Best Performance**
Angling the blades into and away from the wind are important elements in creating maximum power – or slowing the speed of rotation. This experiment will show you the techniques for stalling and furling as well as adjusting the blade pitch to extract the maximum degree of power from the wind.
- **How Much Power Can Be Extracted from the Wind**
While power from the wind is free as long as it blows, it is still limited to certain physical laws. This experiment will show you how to measure wind speed versus extracted wind power.
- **Using Wind Power to Generate Hydrogen**
One important use of wind power is to generate hydrogen in a clean, non-polluting manner. This experiment shows you exactly how to do it.
- **Measure Wind Turbine Performance Using RPM**
Using our electronic measurement tool you can measure the voltage, current, power and RPM (revolutions per minute) rotational speed of the wind turbine and see it displayed on the measurement tool as well as your computer. Watch the RPM as it changes with wind speed and resistor loading and witness how to slow down and even stop the wind turbine spinning without even touching it – just by adding the right resistor combinations. Make measurements for wind power and turbine efficiency to really understand how this remarkable device works.
- **Build a Wind Farm**
Arrange multiple Wind Kit turbines in series and parallel configurations in order to study the voltage, current, and power generated. Design a simulation of a commercial wind farm in model scale and learn the potential of wind power as a mass energy source.

Purchase additional Wind Energy Education Kits and Circuit Board Module Base and red/black hookup leads needed to connect multiple turbines in series and parallel here- <http://www.horizonfuelcell.com/store.htm>

Safety

Before you proceed to perform experiments with the turbine, please note that the rotor can rotate at a few thousand RPM's (Rotations per Minute), especially when no load is connected. When the wind speed is high and the turbine is set to output high power, the rotating speed of the rotor can also be very fast. Bodily injury may result if struck by the rotating blades. Wearing goggles is suggested in the case that your head will be close to the rotating blades. You should also install the turbine properly so that it will not "walk" or topple over. The weight of the base has been increased from previous versions to prevent the turbine from "walking". Placing a rubber mat, polyfoam, or a thin book under the base helps stabilize the turbine if the surface of the table is too hard. In the case that the turbine topples at high rotational speed, to avoid being hurt, do not try to catch it. Arranging the wires from the turbine to run inside the aluminium tube through the opening on the post and base prevents the wires from tangling by the rotating blades. All of the above measures help to reduce accidents during operation of the turbine. However, you have to make sure that the environment is safe for doing experiments. Adult supervision is required. This wind turbine is not suitable for children under 14 years old.