

ecorun2.0 kit - Candle Stirling Engine - Construction Guide

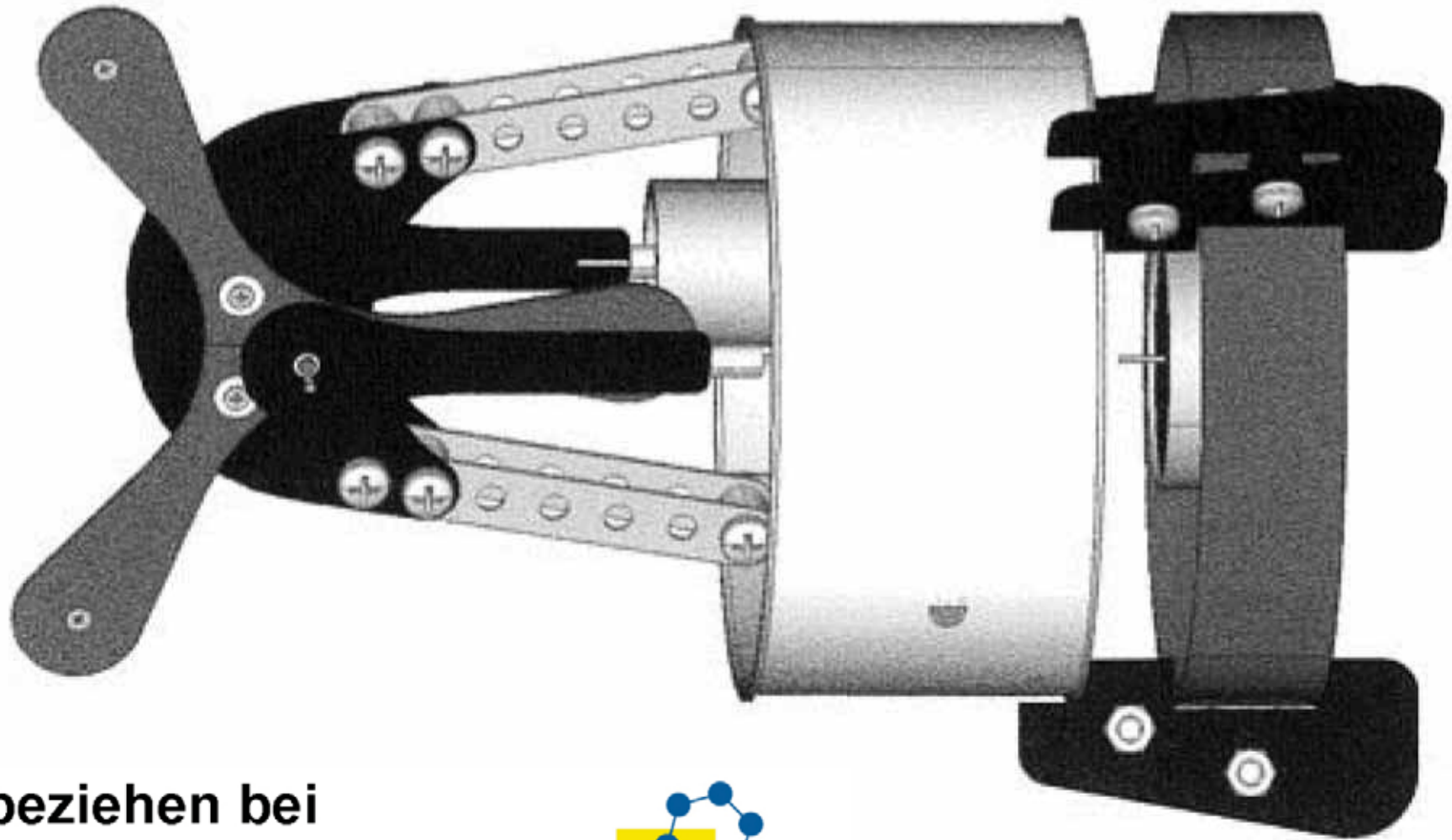

zu beziehen bei
sold by

www.conatex.com



Safety Instructions

Attention: The Stirling Engine **ecorun2.0** is not a toy and not suitable for children under the age of 12.

When running this engine use the same safety precautions as for open fire and flames. Never leave the engine running or the candle burning un-supervised. Never let a stopped engine heat for more than 3 minutes.

Don't touch the engine's bottom cover - burn injury hazard.

Exergia is not responsible for any damages or injury occurring during the operation of this engine.

(1) Introduction

In the early days of the Industrial Revolution, the Edinburgh brothers James and Robert Stirling started working in 1815 on a safer alternative to the established steam engines of the day. By using air instead of steam as the working fluid, the design avoided the then common risk of boiler explosion. The first patent in 1816.

The Stirling engine is a vastly different heat engine to the internal-combustion (diesel or petrol) engine in your car. It has the potential to use any heat source as "fuel" including waste heat and solar energy. As the limits of fossil fuel resources became obvious, scientists and engineers revisited the Stirling principle as a way to exploit alternative energy sources. During the 1980s Prof. I. Kolin (University of Zagreb) and others developed engines based on an adapted Stirling principle capable of operating with a temperature differential of less than 50 degrees Celsius, thus proving the feasibility of exploiting low temperature heat sources to power

modern Stirling engine designs.

The **ecorun2.0** Stirling engine is an an extraordinary engine that demonstrates these concepts with the conversion of medium temperature heat into mechanical work.

(2) Design

The ecorun2.0 Stirling engine consists of five main units:

- x Main working space
'Can' comprising top and bottom housing covers connected by a white cardboard ring
- x Power piston
A graphite piston running in an aluminium power cylinder directly connected to the main working space.
- x Displacer piston
A foam disc inside the main working space.
- x Crankshaft and propeller
Two rods connect the crankshaft to the displacer and power piston – the phase difference between the sinusoidal movement of the pistons is about 90 degrees.
- x Rack with candle

(3) Hints

The kit includes all parts to assemble the engine. No gluing is required. Only common hand tools are required:

- x Small screwdrivers (Phillips N° 1 and N° 2)
- x 7mm (M4 nuts) and 4mm (M2 nuts) spanners are useful but not essential

- x Small flat-nosed pliers
- x Small hammer
- x Craft knife (sharp!) for cutting and de-burring
- x Sand paper for de-burring

Additionally you should have at hand:

- x A small piece of wood, like a child's brick, to press the power cylinder by hand into its ring.
- x A few drops of thin mineral oil (Not vegetable oil!)

The parts are packed in the main working space. Before starting to assemble the engine please carefully remove the top cover (with the black foam displacer on top) and carefully identify all the parts by name and part number given in the parts list. The parts come in six groups:

- x Loose in the can - Parts (1-8)
- x One larger plastic bag - (A.1 - A.7)
- x Five small plastic bags - B.1-3, C.1-5, D1-5, E.1-9, F.1-2

The six stages for assembling the engine are in described in the paragraphs below. All steps that need extra care or additional tests of assembled units are marked with a ♥ in the text.

Please carefully read through each stage before starting work, follow the tips and take your time. Only finger-tighten fasteners to begin with, only tighten properly when the instructions say so.

For further information see: www.exergia.de/ecorun2.0

Have a lot of fun with the **ecorun2.0 kit** engine!

(4) Assembly

(4.1) The Candle Rack - see Fig.1

If necessary, push out from the back (white) any 'chads' left in the punched holes of the ring strips (5) and the disc (6).

To each of the three long M4 screws (C.5), fit two washers (D.5) and a metal angle bracket (B.3). Lay the three ring strips on top of each other so that the holes are staggered by one position to line up one clearance hole (in the middle) through all three strips. Put one of the prepared screws into this hole and fit an M4 nut (D.2) to hold the strips in place.

♥ **Now wrap the three strips into a ring. Be very careful as the cardboard strips are easily broken. You should get a multilayer ring assembly, with every strip starting with one end in the inner layer and its other (rounded) end in the outer layer.**

Fit the other two long M4 screws (C.5) with an M4 nut (D.2) each taking care to get the right orientation of the angle brackets (B.3).

Attach three other angle brackets (B.3) to the disc (6) with a short M4 screw (C.3) and nut (D.2). Now fit the angle brackets on the disc over the three ends of the long M4 screws (C.5) that already hold the ring assembly together. Use two M4 nuts (D.2) for each bracket. Make sure that the inner M4 nuts are flush with the ends of the screws to make a proper seat for the tea light candle (9).

Assemble two black supports (A.1) to each angle bracket on the ring assembly. Use two medium M4 screws (C.4), two black distance pieces (B.2), two M4 nuts (D.2) for each bracket and don't forget one M4 washer (D.5) for the upper distance piece.

♥ Now fit the candle (9) and the housing ring (3) with its bottom cover (1) into the rack, adjusting the supports and brackets so that everything fits well. Finally, tighten all screws and nuts.

(4.2) The Top Cover - see Fig.2

Remove the power piston from its cylinder. With a craft knife and/or sand paper, carefully remove any burrs from the edges of the power cylinder (E.1) and its ring (8).

♥ Very carefully clean all traces of dust from the power cylinder. Refit the piston and check that it glides smoothly inside the cylinder without noticeable friction or any sticking.

Place the ring (7) on a hard flat surface and carefully push the power cylinder into it using hand pressure. Making sure that it stays vertical to avoid the cylinder jamming. A small piece of wood on top of the cylinder may help to increase hand pressure to push it down flush.

Cut two 2mm long pieces of the medium sized flexible tube (E.7). Fix the last two angle brackets (B.3) on the top of the cover using long M2 screws (C.2), the medium sized M3 washer (D.4), the tube piece, the small M3 washer (D.3) and the M2 nut (D.1).

♥ Take care that with the correct orientation of the brackets.

Fit the power cylinder and ring to the top cover (2) using the four long M2 screws (C.2), the medium M3 washers (D.4) and the M2 nuts (D.1).

♥ As a first step, only finger-tighten the nuts. Ensure that there is no gap between the ring and the top cover before final tightening the nuts.

(4.3) Crankshaft Support Assembly - Fig.3a/b

Fit four M4 x 16 screws (C.4) into the holes in one of the crankshaft support plates (A.2) and lay it on the table with the screw heads down. Fit two of the metal strips (A.5), the white distance pieces (B.1), two more metal strips and the second support plate (A.2), fastening this stack with four M4 nuts (D.2).

♥ Attach this assembly to the metal angle brackets on the top cover with two more M4x16 screws (C.4), distance pieces (B.1) and M4 nuts (D.2) in the highest position possible - see fig.3b. Tighten the two screws firmly.

♥ Fit the main axle of the large crank disc (E.1) into the bushes. It must be horizontal, and perpendicular to each support plate (A.2). If not, adjust by slightly moving the supports relative to each other.

Now final tighten the four screws and their nuts.

♥ The complete assembled upper structure should be perpendicular to the upper cover surface. If this is not the case carefully correct this by slightly bending the metal strips.

(4.4) Propeller and Crank Disc Assembly - Fig.4

If necessary, push out from the back (white) any 'chads' left in the punched holes of the propeller blades A (A.6) and B (A.7). Fastened pairs of blades together - white sides face to face - with short M2 screws (C.1), M3 washer (D.4) and the M2 nut (D.1) to the crank disc (E.1). Then fasten together each blade pair at their outer ends with M2 screws (C.1) and nuts (D.1) - no washers.

♥ Take care that each blade's surface is perpendicular to the main axle.

(4.5) Fitting and Adjustment of Crank Discs - Fig.5

The central hole in the small crank disc (E.2) has to be enlarged using the long pin (E.5) as a tool.

♥ **With a small hammer, carefully drive the tool pin (E.5) into the central hole in the crank disc taking care that it is perpendicular to the disc.**

Using the pliers, carefully pull out the pin. Now turn the crank disc over and drive the short pin (E.3) into the outer hole.

Cut two 2mm long pieces of the thin flexible tube (E.6) and fit one each to the axle and the pin of the large crank disc (E.1). Put one of the small beads (E.9) on the axle and pass the axle through the bushes of the support assembly. Put another bead on the free end of the axle. Hold the large crank disc with one hand - grasp between the propeller blades. With your other hand, twist the small disc on to the axle. Ensure that the axle has about a half millimetre of end-play (float).

♥ **Test the free running of the propeller. After a flick with your finger, it should continue to spin for about two seconds.**

Now it's time to adjust the off-set between the two crank discs. This provides the so-called 'phase difference', the correlation between the movement of the two pistons. It should be somewhere about 90 deg. Imagine the pins in the two crank discs as the hands of a clock. Looking at the propeller from the front, turn it until its crank pin is in the 12 o'clock position. Hold the large crank disc in this position, and twist the small crank disc until its pin is at 9 o'clock as seen from the same (propeller) end. Set like this, the engine will run clockwise. If you set the small crank disc's pin to 3 o'clock, the engine will run anti-clockwise.

(4.6) The Connecting Rods - Fig.6

From the thin flexible tube (E.6), cut two 3mm lengths and two 8mm lengths. From the thick flexible tube (E.8), cut two 8mm lengths. Carefully push an 8mm lengths of (E.8) onto the narrow end of each connecting rod - the Power Piston Con Rod (A.4) the Displacer Piston Con Rod (A.3).

♥ **Be very careful as you can easily break the cardboard.**

Insert the the medium sized pin (E.4) into the gap between the tube and the connecting rod (referenced to below as con rod tube and pin). The pins must protrude 5mm below the lower end of the con rods. Push an 8mm length of the thin flexible tube (E.6) about 4mm over the bare end of each pin (E.4).

(4.6.1) Power Piston Con Rod (PPC)

Push pin of the power piston (F.2) about 3mm into the open end of the PPC tube; this should leave a gap inside the tube of about 1mm between the ends of the two pins. Insert the power piston into its cylinder. Fit a bead (E.9) onto the the pin of the small crank disc (E.2) followed by the head of the PPC and a second bead (E.2). Push a 3mm length of the thin flexible tube (E.6) onto the open end of the crank pin to stop the con rod coming off. Ensure that there is a slight gap (about half a millimetre) between the bead and the tube.

♥ **Manually spin the propeller to test the free movement of the power piston. The power piston must not touch the top cover. If necessary readjust the PPC pin.**

(4.6.2) Displacer Piston Con Rod (DPC)

Now fit the top cover over the displacer piston (4) pin so that the

piston will eventually be inside the working space (the 'can'). Push the displacer piston's pin about 3mm into the open end of the DPC's tube. Then finish assembling the DPC onto the propeller crank pin as you did with the PPC. The easiest way to fit the DCP onto the crank pin is to rotate the prop until the pin is in its uppermost position.

♥ **The assembled displacer piston should have a minimum distance from the top cover of about one millimetre in its upper position.**

♥ **Check the free running of the propeller. If necessary readjust the propeller blades.**

♥ **Take care to orientate the con rods correctly. The pins must be on the side of the con rods that faces the support plates (A.2).**

(4.7) Closing the Housing and Lubrication

Now carefully press the top cover (2) with the complete upper assembly into the housing ring.

The engine has five bearing bushes: two bushes for the main axle in the support plates, two bushes in the connecting rods and one in the top cover to guide the displacer rod. Use a thin piece of wire or the long cylindrical pin (E.5) to apply a tiny drop of machine oil to each pin or axle where it goes through the bushes. Make sure that the oil goes into the bearing.

♥ **DO NOT get any oil on the power piston or cylinder!**

Now your engine is ready for the first test run.

(5) Operating Instructions

Before starting, make sure that you're set up on a fireproof base in a dry and draft-free environment.

Put the tea light candle into the rack, light the candle and fit the engine centred on top of the rack over the burning candle. After a minute or two, flip the prop in a clockwise direction (assuming you are looking toward the prop, see paragraph 4.5). The **ecorun2.0** engine should start immediately and will run for more than three hours - the burning time of the candle.

Please note that the size of the candle flame may vary during burning resulting in the engine's speed varying anywhere between 200 and 600 rpm.

The candle flame must never touch the surface of the lower housing cover. If necessary, shorten the candle's wick with a pair of scissors.

(6) Troubleshooting

If you can't get your engine to operate properly or not run at all, go through the following check list step by step, fixing any problems identified.

(6.1) Sealing of the Working Space

The working space must be fairly air-tight. Normally all of the screwed and pressed connections should provide adequate sealing of the engine. To check there are no major leaks, remove the power piston con rod from its crank pin and see how fast the power piston sinks down the cylinder. Not much below two seconds indicates adequate sealing of the engine.

Critical points for the sealing are as follows:

- x The screws holding the metal brackets onto the top cover.
 - ▶ Tighten up the fastenings of the angle brackets. If necessary, remove the top cover.
- x There is a small gap between the power cylinder ring and the top cover. ▶ Try reassembling with the cylinder and ring rotated (90 or 180 deg) on the cover. If this does not help, fill the gap with some glue.
- x There is a leakage between the power cylinder and its ring.
 - ▶ Fill the gap with some glue
- x If the top cover has been removed from the housing ring several times, there may be a poor seal between cover and ring. ▶ Fill the gap with glue. Beware: after doing this you won't be able to remove the top cover again. If necessary you may open the housing from the bottom side.

If you have problems locating the leakage, put a drop of washing-up liquid in a little water and apply sparingly to the places above in question. Manually rotate the propeller. Little bubbles will show where air is leaking. Make sure you dry the engine properly.

(6.2) Mechanical Friction

Reread all hints in this guide that relate to free running and axial play. In particular that:

- x There is not enough axial play on the main axle. ▶ Carefully pull the small crank disc slightly (a few tenths of a millimetre) along the main axle away from the support plate.
- x The con rods do not move freely on the crank pins. ▶ Readjust the retainers (E.6).

(6.3) Free Running Pistons

Reread the related hints in the paragraph 4.6 "Connecting Rods".

- ▶ Readjust pins and flexible tubes if needed.

If any moisture has entered the engine's working space (perhaps when checking for leaks), water may have condensed in the gap between the power piston and cylinder, causing the piston to stick.

- ▶ Disassemble the power piston together with its con rod and dry it. Leave it disassembled for a while so any residual moisture may evaporate.

(6.4) Crank Phase Difference

The movement of the two pistons must be approximately 90° out of phase. Reread the paragraph 4.5 "The Connection and Adjustment of the Crank Discs". ▶ Readjust the small crank disc if needed.

(6.5) Engine Heating

To ensure sufficient heating, the candle flame needs to be at least 10 to 15 millimetres high. If necessary, replace the candle.

A draft-free environment is essential to ensure optimal heat transfer from the candle flame to the bottom housing cover.

(7) Credits

Many thanks to Guy Attfield for the help with this English version of the construction guide.

Fig.1 Assembly of the Candle Rack

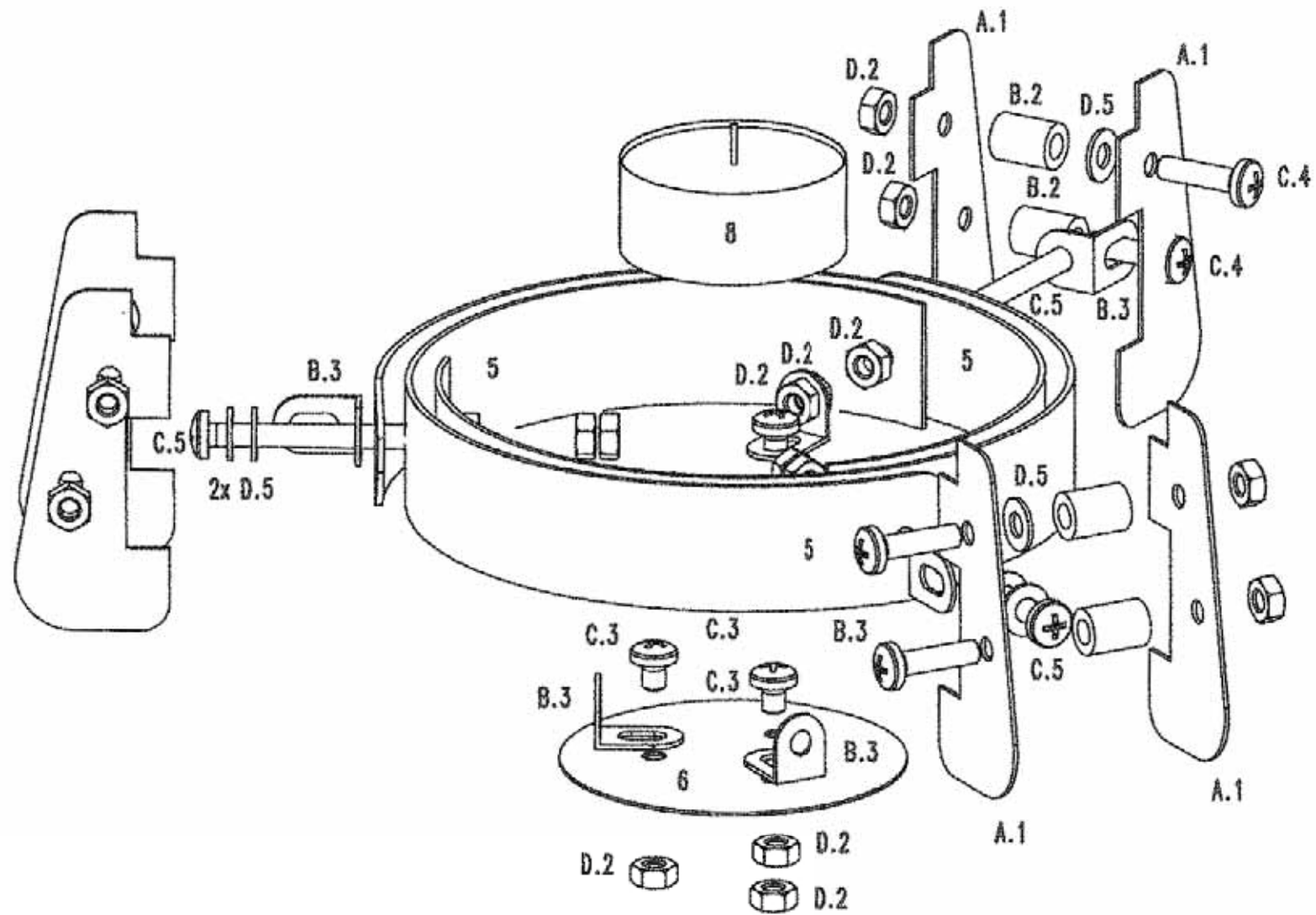

Fig.2 - Assembly of the Top Cover

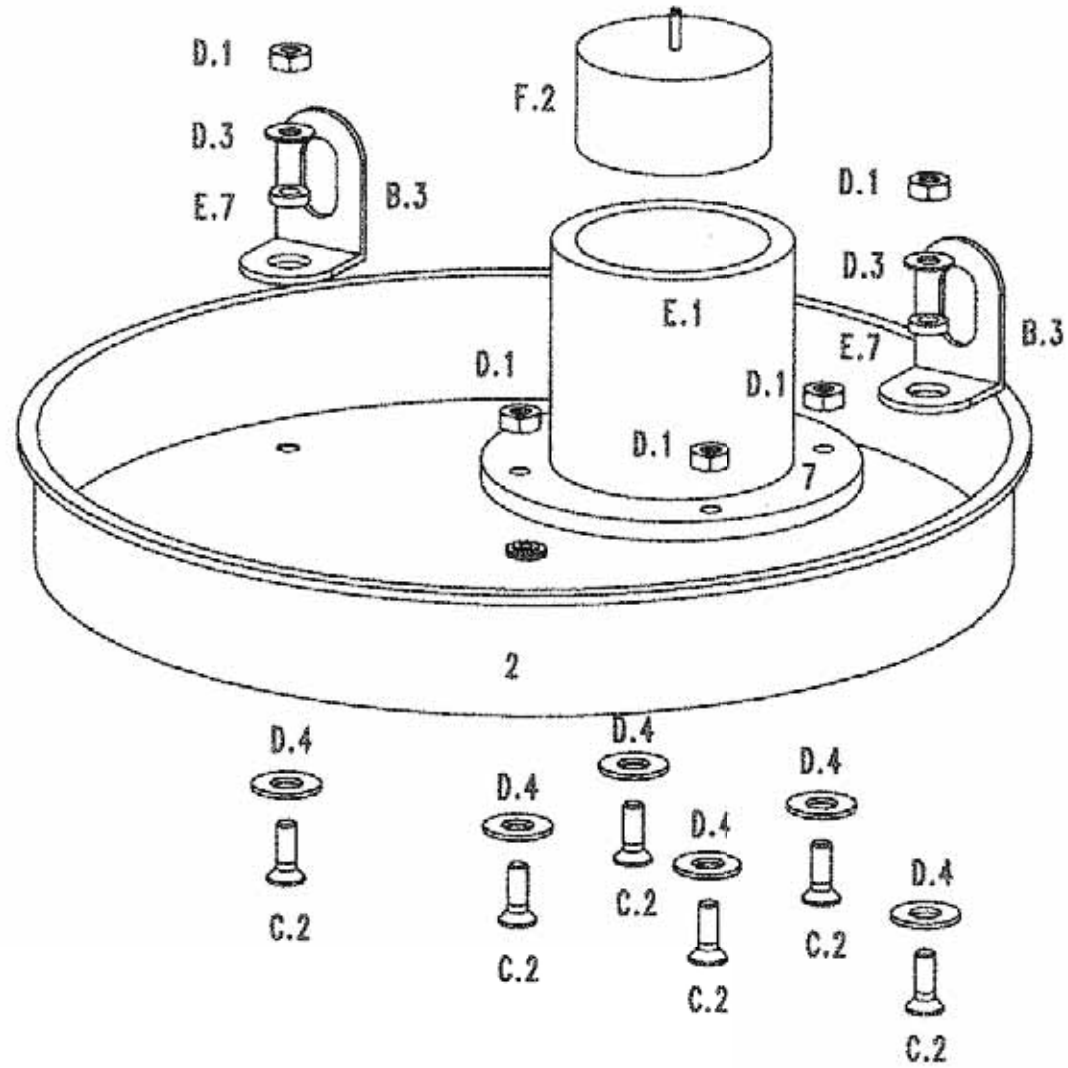

Fig.3a - Assembly of the Support Structure of the Crankshaft

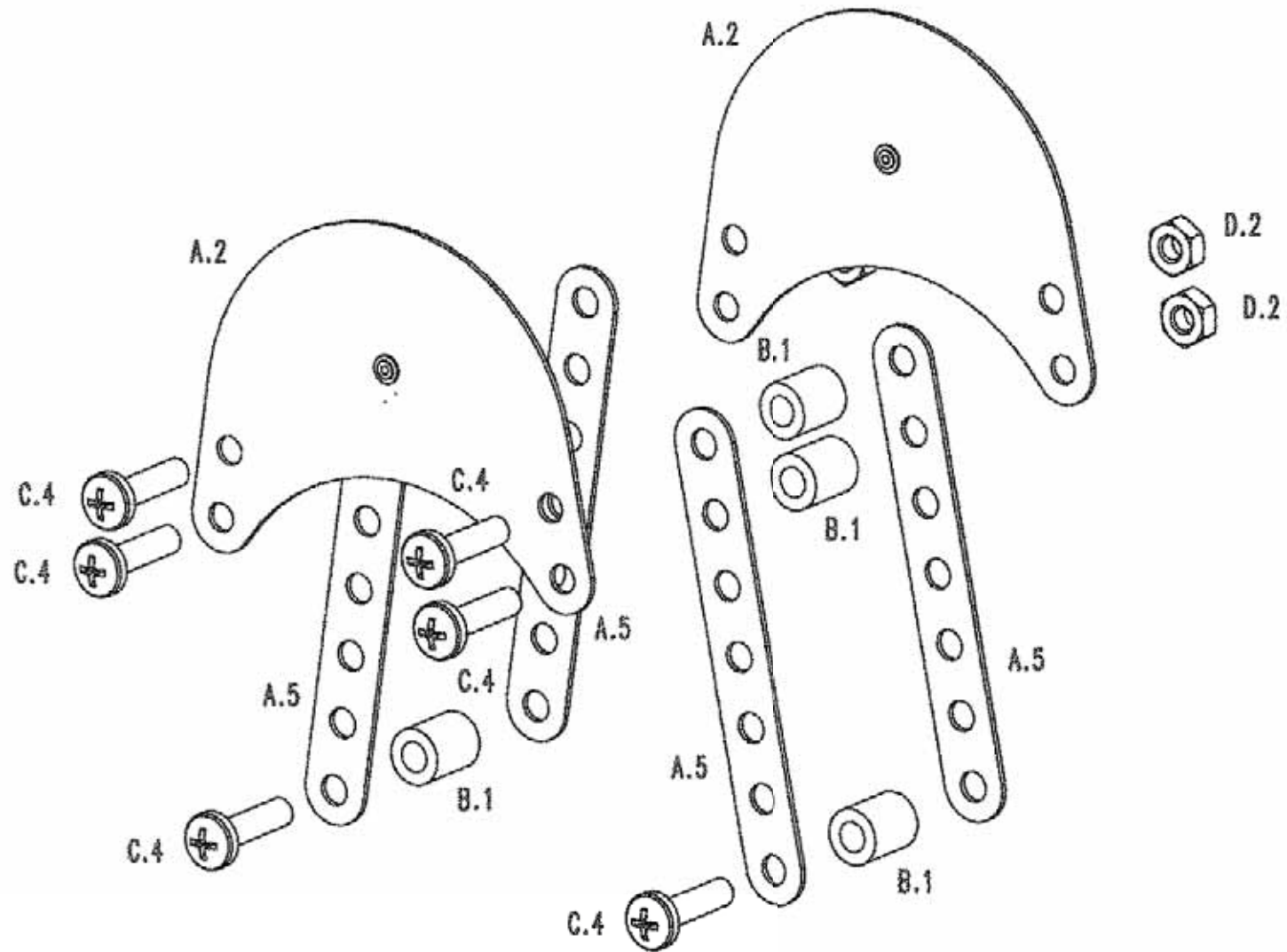

Fig.3b - Connection of Support Element to Top Cover

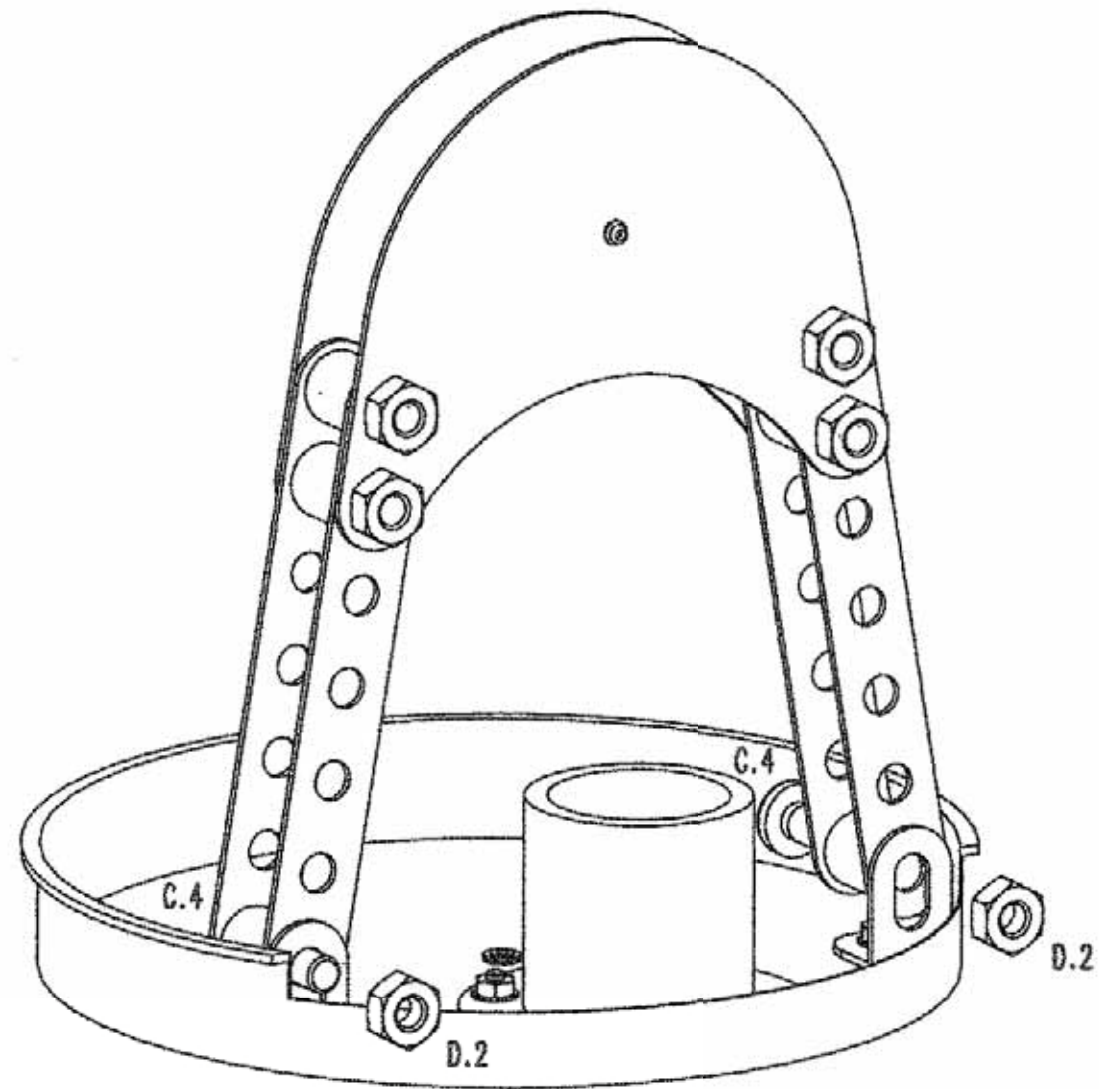

Fig.4 - Connection of the Propeller Blades to the Crank Disc

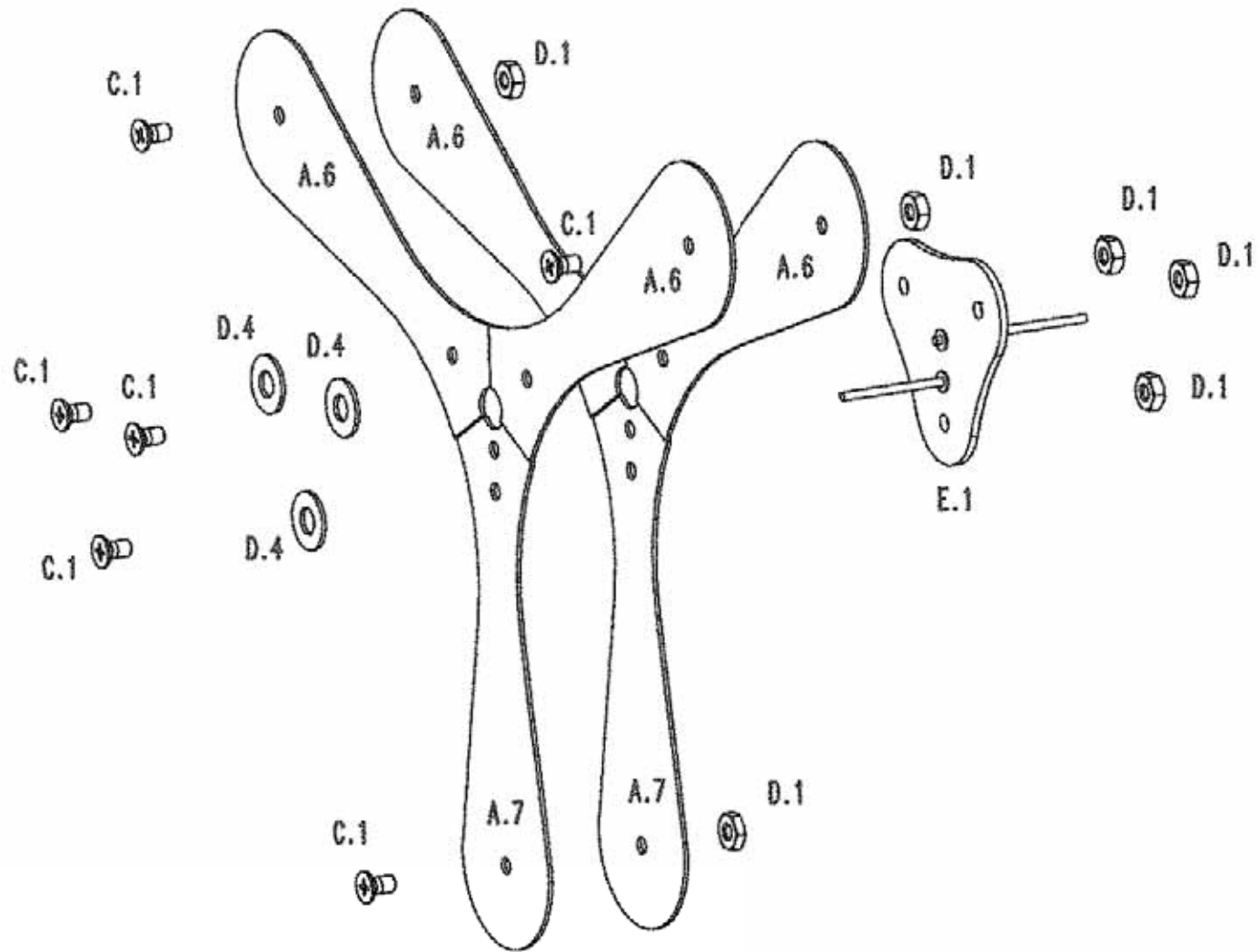

Fig.5 - Connection and Adjustment of the Crank Discs

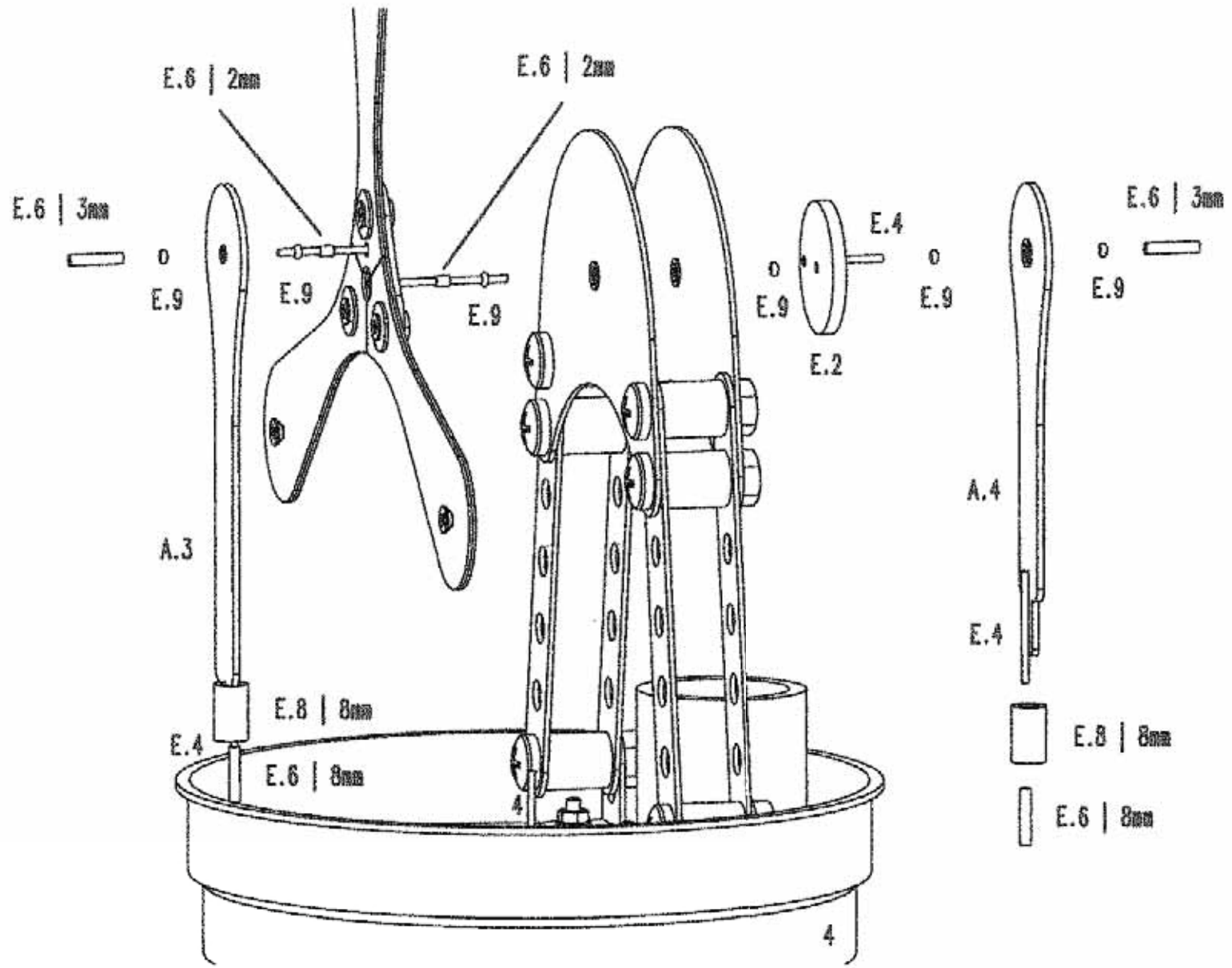
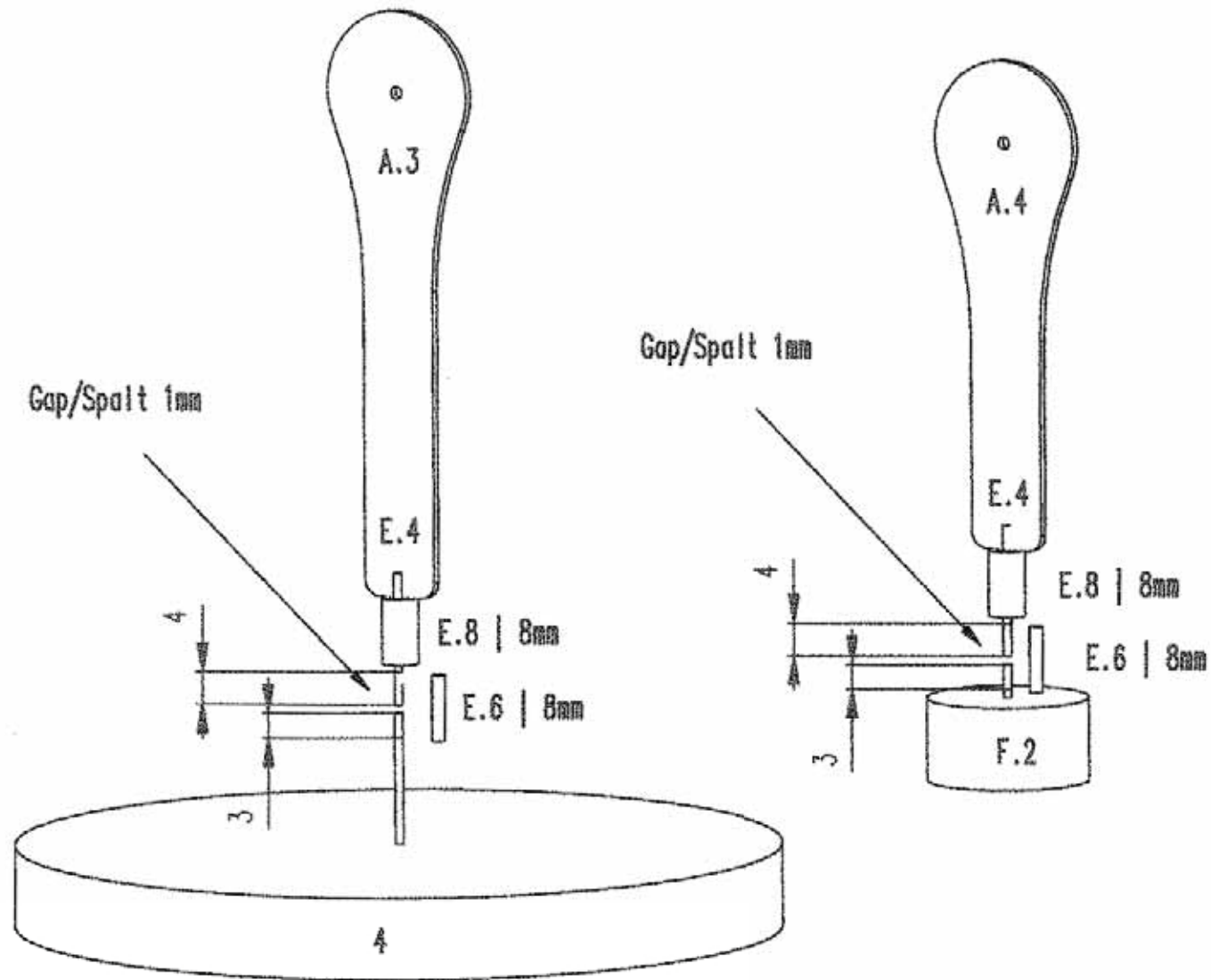

Fig.6 - Connection of the Connecting Rods to the Pistons



Parts list (Number | Part | Quantity)

1	Housing cover, bottom	1
2	Housing cover, top	1
3	Housing ring	1
4	Displacer piston with rod	1
5	Ring strips, rack	3
6	Disc, rack	1
7	Power cylinder ring	1
8	Tea light candle, Fuel	1
A.1	Support, rack	6
A.2	Support plate, crankshaft	2
A.3	Displacer Piston Con-rod (DPC), long	1
A.4	Power Piston Con-rod (PPC), short	1
A.5	Metal strip, 7 holes	4
A.6	Propeller blade A (2 holes)	4
A.7	Propeller blade B (3 holes)	2
B.1	Distance piece, white, 8mm	6
B.2	Distance piece, black, 11mm	6
B.3	Metal angle bracket	8
C.1	Flat-head Screw, M2 x 4, short	6
C.2	Flat-head Screw, M2 x 6, long	6

C.3	Cheese-head Screw, M4 x 5, short	3
C.4	Cheese-head Screw, M4 x 16, medium	12
C.5	Cheese-head Screw, M4 x 35, long	3
D.1	Nut, M2	12
D.2	Nut, M4	24
D.3	Washer M2, Ø inner=2,2mm, small	2
D.4	Washer M3, Ø inner=3,2mm, medium	9
D.5	Washer, M4, Ø inner=4,2mm, large	9
E.1	Crank disc with main axle and pin, large	1
E.2	Crank disc, small	1
E.3	Pin 1x12, short	1
E.4	Pin 1x16, medium	2
E.5	Tool , Pin 1x26, long	1
E.6	Flexible tube, outer diameter 1.6mm, Length~30mm, thin wall, to be cut: 2x 2mm, 2x 3mm, 2x 8mm	1
E.7	Flexible tube, outer diameter 4.5mm, Length~10mm, medium wall, to be cut: 2x 2mm	1
E.8	Flexible tube, outer diameter 5mm, Length~30mm, thick wall, to be cut: 2x 8mm	1
E.9	Bead, spacer	6+2
F.1	Power cylinder	1
F.2	Power piston with pin	1

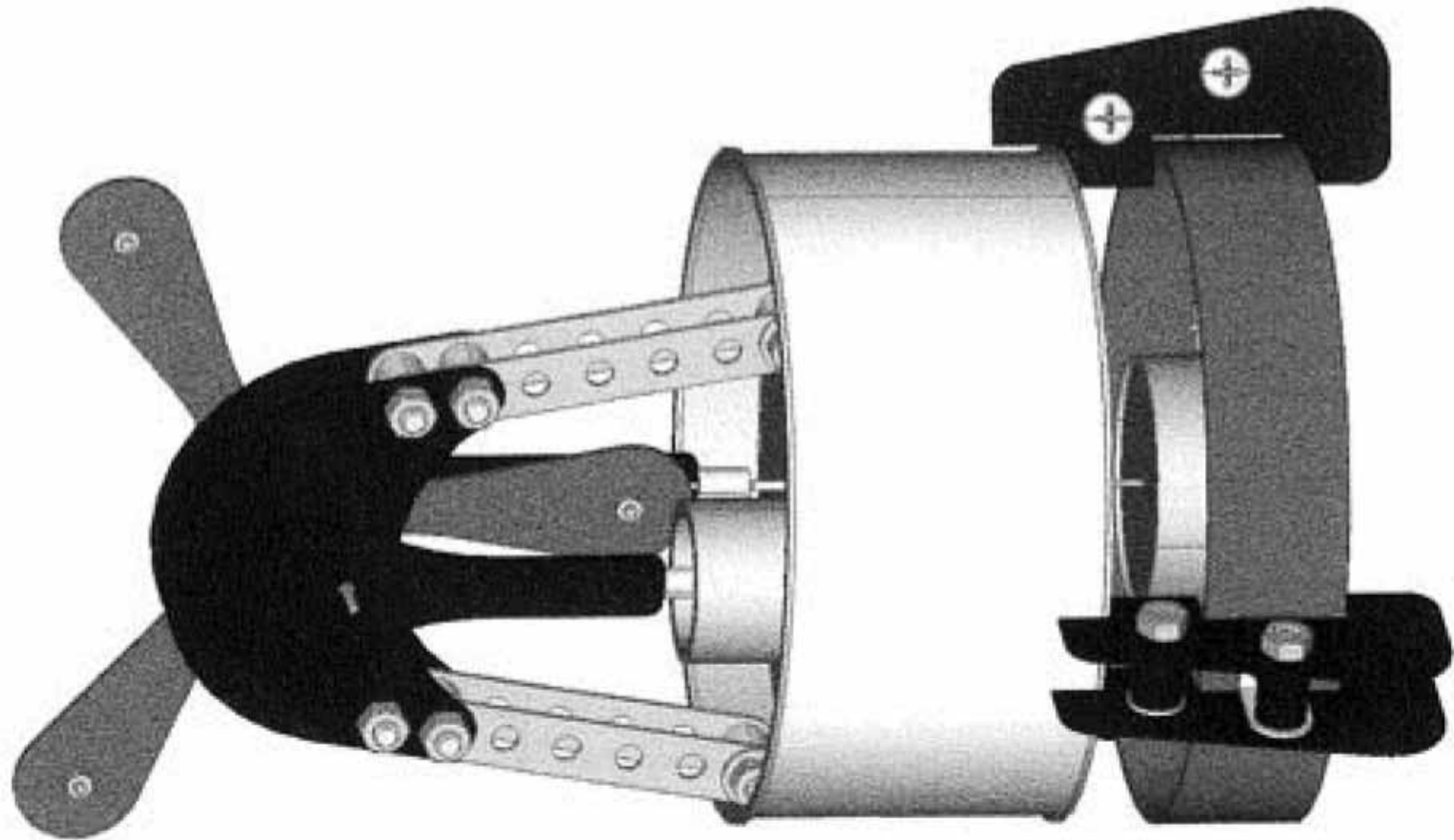

ecorun2.0 kit