

PASCO Structures System Load Cell, 100 N

PS-2200

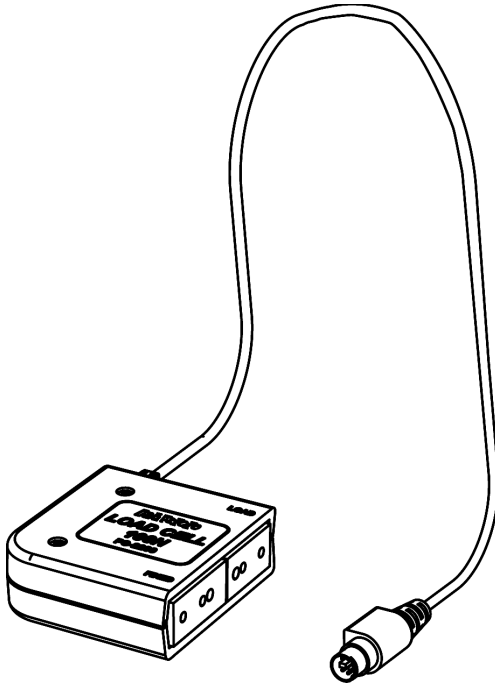

Recommended Equipment

- Load Cell Amplifier (PS-2198)
- PASPORT Interface

Related Equipment

- Complete Structures Set (ME-6989)
- Truss Set (ME-6990)
- Bridge Set (ME-6991)
- Advanced Structures Set (ME-6992)
- Load Cell & Amplifier Set (PS-2199)

See www.pasco.com for details about PASPORT Interfaces and PASCO Structures System parts and sets.

Introduction

The Load Cell, 100 N is designed to work with the PASCO Structures System. When connected to a PASCO interface through the PS-2198 Load Cell Amplifier, the Load Cell can measure compression and tension forces in any component of the PASCO Structures System.

For example, the PASCO Structures System includes the ME-6990 Truss Set, ME-6991 Bridge Set, and the ME-6992 Advanced Structures Set.

About the Load Cell

The PS-2200 Load Cell measures forces ranging from -100 N to 100 N and is wired with a male 6-pin min-DIN connector for plugging into the PS-2198 Load Cell Amplifier.



Figure 1: The Load Cell has a semi-transparent case

The PS-2198 Load Cell Amplifier supports up to six PS-2200 Load Cells. The PS-2199 Load Cell and Amplifier Set includes one Load Cell Amplifier and four Load Cells.

Adding Load Cells

To measure the compression and tension forces in individual members, add load cells (PS-2200) to any PASCO Structure. Replace a beam with two shorter beams and a load cell.

#5 beam = load cell + two #3 beams

#4 beam = load cell + two #2 beams

#3 beam = load cell + two #1 beams

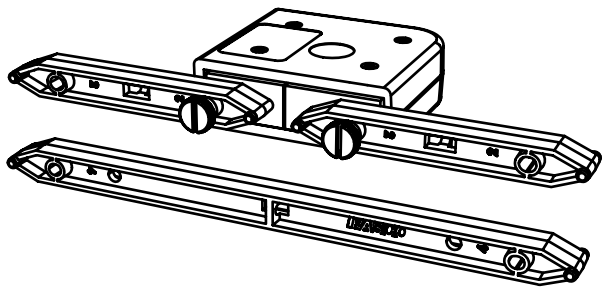

Figure 2: A load cell combined with two #2 beams is the same length as a #4 beam

Use thumbscrews to attach two beams to a load cell as shown in Figure 2.

When using load cells, assemble your structure with the screws loose. This will simplify the analysis by ensuring that the members experience only tension and compression without moments.

Plug the mini-DIN connector at the end of the load cell cable into a port on the Load Cell Amplifier (PS-2198). See the instructions that came with the load cell amplifier for details about how to connect the load cell amplifier to an interface or datalogger and collect data.

Example: Bridge with Load Cells

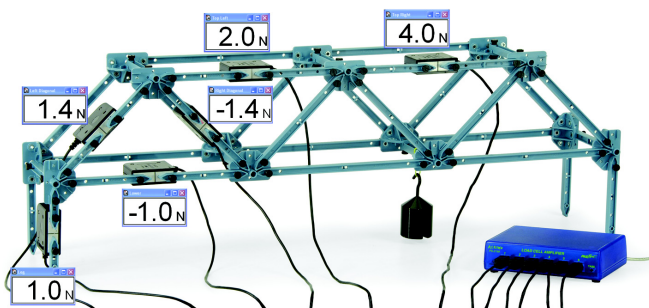

Figure 3: Bridge with load cells

The bridge shown in Figure 3 incorporates six load cells to measure the tension or compression in various members. A hanging mass is used to apply load. The mass is adjusted so that the compression in one of the legs is 1.0 N. Compression is registered as a positive value and tension as a negative value.

If the screws are loose, the theoretical analysis of the bridge can be carried out by assuming that the net force at each node is zero. Thus, the vertical component of compression in the left-most diagonal member must be 1 N (to oppose the force applied by the leg). The horizontal component must also be 1 N since the member is at a 45° angle. The predicted resultant force is:

$$\sqrt{(1.0 \text{ N})^2 + (1.0 \text{ N})^2} = 1.4 \text{ N}$$

The actual measured force confirms the theory.

Calibration of Load Cells

Load cells are factory calibrated; however, you can recalibrate them in software or on the datalogger. See the documentation for your software or datalogger for instructions.

When calibrating a load cell, it is necessary to apply a known load. Assemble the fixture shown in Figure 4 to support the load cell. Hold or clamp the fixture at the edge of a table and hang a mass from it as shown.

Note that the hanging mass applies tension to the load cell; therefore the known force that you enter into the software or datalogger should be a negative value. For example, if the mass is 1.0 kg, the applied force is -9.8 N.

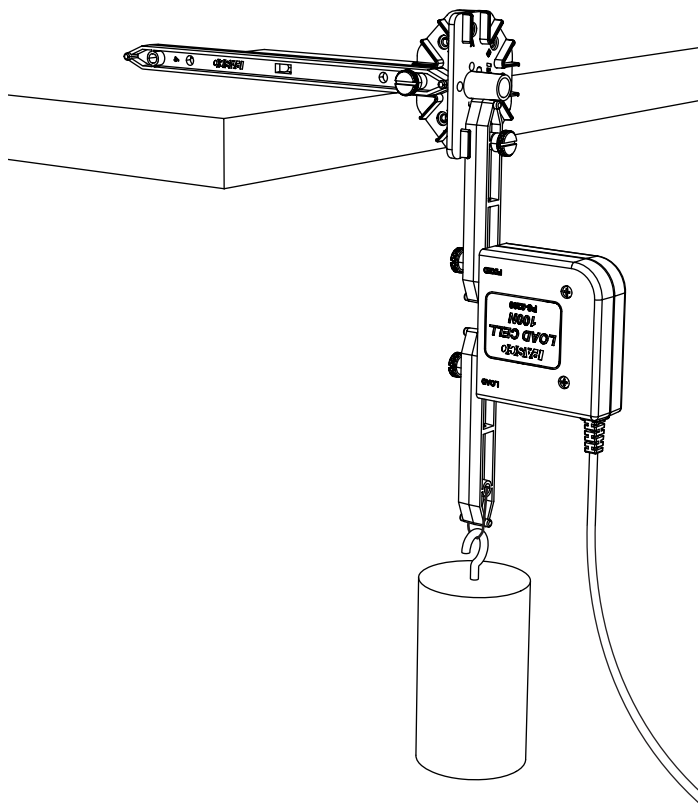
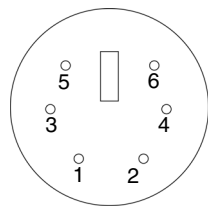

Figure 4: Calibration fixture

Specifications

Range	-100 N to +100 N
Dimensions	5.3 cm by 5.8 cm by 2.0 cm
Length of cable	120 cm
Mass	approximately 100 g

Pinouts



Pin	Signal
1	+ Strain Gauge Output
2	+ 4.2 V
3	- Strain Gauge Output
4	Ground
5	Range Select 1
6	Range Select 2

Technical Support

For assistance with any PASCO product, contact PASCO at:

Address: PASCO scientific
10101 Foothills Blvd.
Roseville, CA 95747-7100

Phone: 916-786-3800 (worldwide)
800-772-8700 (U.S.)

Fax: (916) 786-7565

Web: www.pasco.com

Email: support@pasco.com

For more information about the Load Cell, 100 N and the latest revision of this Instruction Sheet, visit:

www.pasco.com/go?PS-2200

Limited Warranty For a description of the product warranty, see the PASCO catalog. **Copyright** The PASCO scientific 012-10638A *Load Cell, 100 N Instruction Sheet* is copyrighted with all rights reserved. Permission is granted to non-profit educational institutions for reproduction of any part of this manual, providing the reproductions are used only in their laboratories and classrooms, and are not sold for profit. Reproduction under any other circumstances, without the written consent of PASCO scientific, is prohibited. **Trademarks** PASCO and PASCO scientific are trademarks or registered trademarks of PASCO scientific, in the United States and/or in other countries. All other brands, products, or service names are or may be trademarks or service marks of, and are used to identify, products or services of, their respective owners. For more information visit www.pasco.com/legal.