

Wind Velocity Accessory

ME-6812

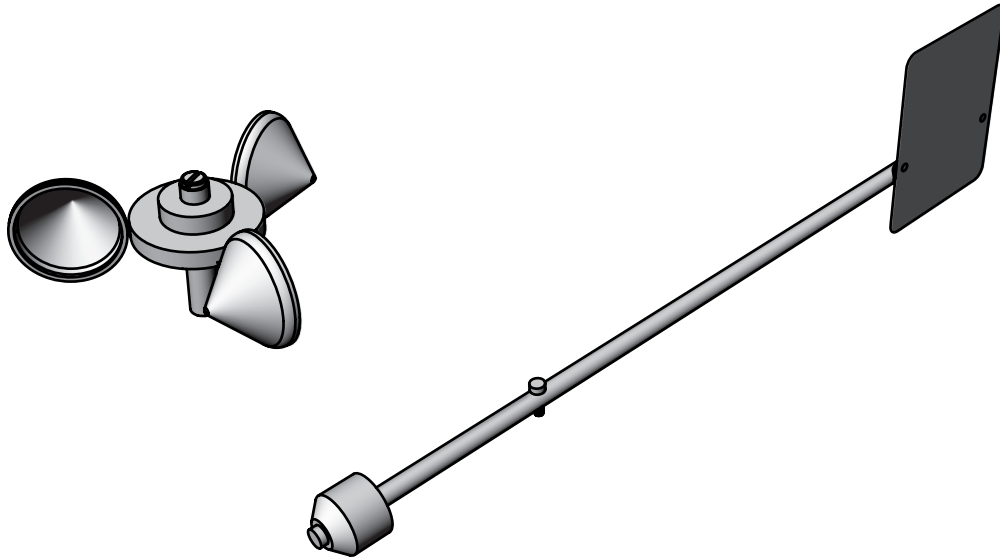

Included Equipment	Part Number
Anemometer	003-09877
Wind Vane	003-09878
Thumbscrew	613-076
Additional Equipment Needed ¹	
PASPORT Rotary Motion Sensor ²	PS-2120
Xplorer GLX	PS-2002
Mounting stands rods and clamps	See PASCO catalog

¹The Wind Velocity Accessory is compatible with any PASCO rotary motion sensor and interface; however, PASPORT sensors and Xplorer GLX interface are recommended for mobile data collection and display.

²Two (2) rotary motion sensors are needed for simultaneous measurement of speed and direction.

Introduction

The ME-6812 Wind Velocity Accessory includes two attachments that can be used with a rotary motion sensor (RMS). The anemometer attachment allows the RMS to measure wind speed; the wind vane allows it to measure wind direction. The attachments can be used one-at-a-time with a single RMS, or simultaneously with two RMSs.

The Wind Velocity Accessory is designed for use in dry weather. See page 3 for suggested activities.

RMS Set-up

1. Mount the RMS near the top of a vertical support rod as illustrated (right) or on a horizontal rod (next page).
2. Connect the RMS to your interface.

Repeat the above steps if you plan to use two RMSs.

Note: Position the RMS with the PASCO logo to top as illustrated; otherwise wind speed will be recorded as negative, and direction will be "backwards."

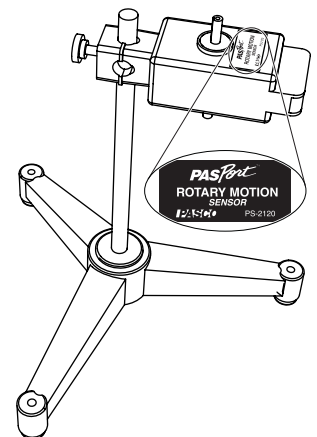

Anemometer Set-up

Slide the anemometer onto the RMS shaft as illustrated.

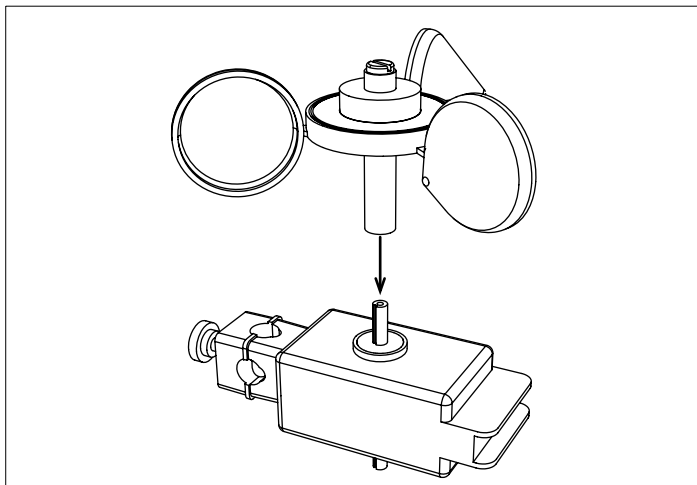

Wind Vane Set-up

1. Slide the three-step pulley (included with the RMS) onto the RMS shaft as illustrated.

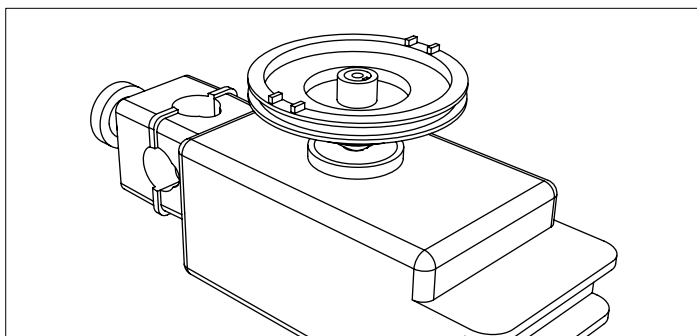

2. Align the shaft of the wind vane with the tabs on the pulley and secure it with the thumbscrew.

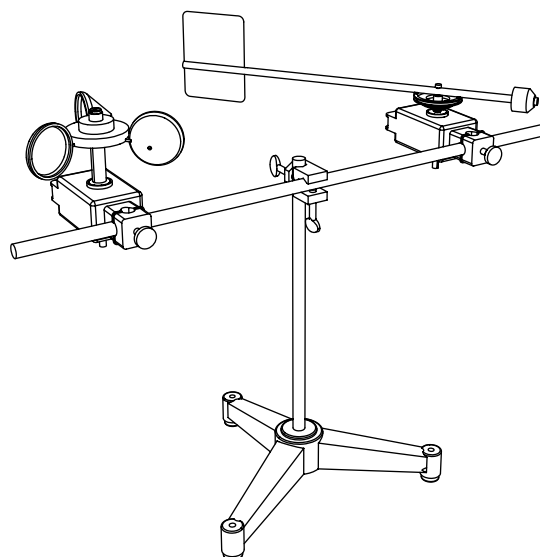
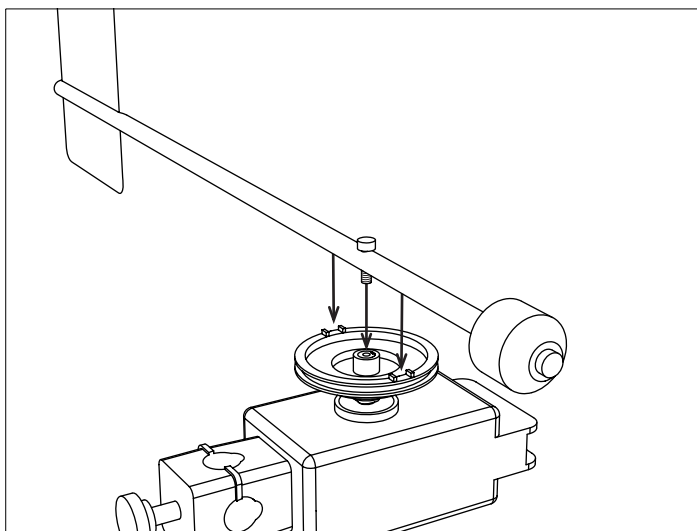

Two-sensors mounted on a horizontal rod

Wind Speed Calculation

The rate at which the anemometer rotates is proportional to the wind speed. For automatic wind-speed calculation (in m/s), enter the following in the Calculator of the Xplorer GLX or DataStudio:

$$\text{wind speed} = 0.15 * [\text{Angular Velocity (rad/s)}]$$

The scale factor (0.15 m/rad) was determined from the slope of the speed versus angular velocity graph on page 3.

Wind Direction Calculation

Follow these steps to express wind direction as an angle between 0° and 360° with north = 0°, east = 90°, etc.

1. Define north as 0°.

Xplorer GLX: Go the Sensor screen, highlight the “Zero Sensor Automatically On Start” setting, and press  and select “Zero Sensor Now.”

DataStudio: Open the Experiment Setup window, turn off the “Zero sensor automatically on start” option in the Sensors screen. Click the **Zero Sensor** button.

2. Enter the following new calculation in the Calculator of the Xplorer GLX or DataStudio:

$$\text{wind direction} = \text{mod}(360 + \text{mod}([\text{Angular Position (deg)}], 360), 360)$$

Examples

Wind Speed versus Angular Velocity The data in the graph below were recorded in calm weather with the anemometer attached to the outside of a car. The vehicle speed was recorded using a GPS Sensor (PS-2175). The graph shows the linear relationship between the vehicle speed and the angular velocity (or rotation rate) of the anemometer.

Note: Be sure to keep the anemometer level; otherwise it may be blown off the RMS shaft.

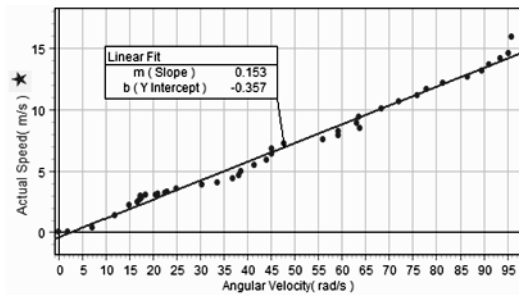

Calculations The screen shots below show the wind speed and direction calculations in DataStudio (version 1.9.7r12) and on the Xplorer GLX.

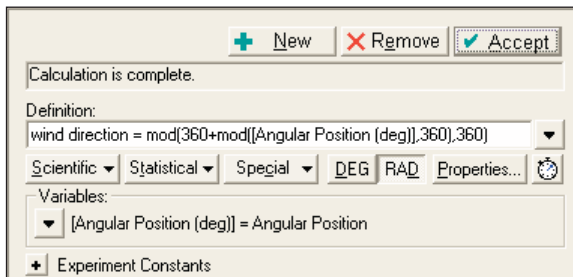
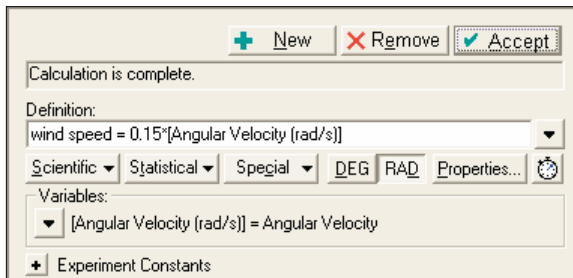

DataStudio (version 1.9.7r12)
Calculator Windows

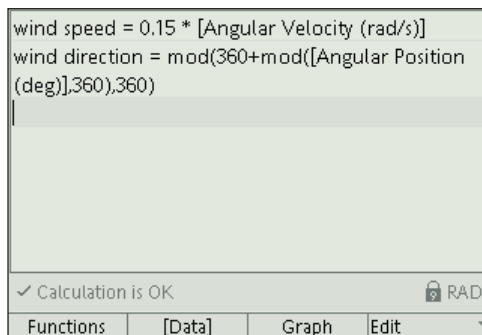

Xplorer GLX Calculator Screen

Suggested Activities

- On a windy day, measure how the wind velocity experienced from a moving vehicle relates to the vehicle's ground speed and direction of travel.
- Mount the anemometer on a bicycle or other vehicle to explore how wind affects vehicle speed.
- Use two anemometers or wind vanes simultaneously to measure wind speed or direction at two locations. For instance, measure wind speed close to the ground and a few meters up; measure wind direction close to a building and away from it. How do stationary objects such as the ground, trees, buildings, and hills affect wind velocity?

Technical Support

For assistance with any PASCO product, contact PASCO at:

Address: PASCO scientific
10101 Foothills Blvd.
Roseville, CA 95747-7100

Phone: 916-786-3800 (worldwide)
800-772-8700 (U.S.)

Fax: (916) 786-7565

Web: www.pasco.com

Email: support@pasco.com

Limited Warranty For a description of the product warranty, see the PASCO catalog.

Copyright The PASCO scientific 012-09888A *Wind Velocity Accessory Instruction Sheet* is copyrighted with all rights reserved. Permission is granted to non-profit educational institutions for reproduction of any part of this manual, providing the reproductions are used only in their laboratories and classrooms, and are not sold for profit. Reproduction under any other circumstances, without the written consent of PASCO scientific, is prohibited.

Trademarks PASCO, PASCO scientific, DataStudio, PASPORT, and Xplorer GLX are trademarks or registered trademarks of PASCO scientific, in the United States and/or in other countries. All other brands, products, or service names are or may be trademarks or service marks of, and are used to identify, products or services of, their respective owners. For more information visit www.pasco.com/legal.