

**Instruction Sheet
for the PASCO
Model ME-9481**

Bernoulli Cart Accessory

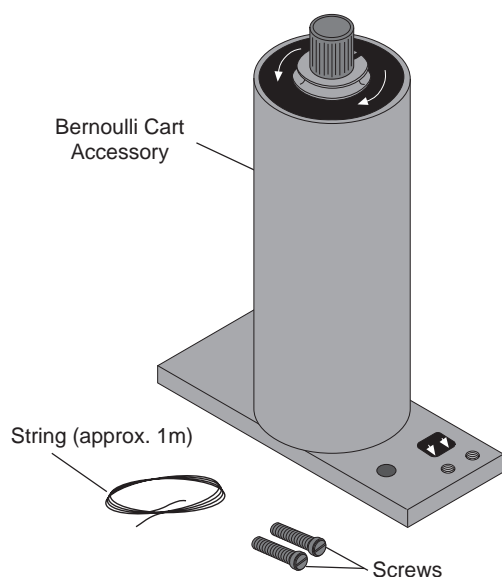

Introduction

The PASCO ME-9481 Bernoulli Cart Accessory attaches to the PASCO Dynamics Cart (ME-9430) or Collision Cart (ME-9454) to demonstrate Bernoulli's Principle. The cart should be used on a PASCO Dynamics Track to minimize friction. A fan (approximately 6-inch to 12-inch diameter) is required to supply moving air.

The Bernoulli Cart Accessory consists of a vertical cylinder that can be rotated rapidly by pulling on a string. (► **NOTE:** String for spinning the cylinder and two screws for mounting the apparatus on a PASCO cart are included.) When the fan blows air perpendicularly across the track, the cart moves along the track in a direction corresponding to the direction of rotation of the cylinder.

Theory

According to Bernoulli's Principle, the pressure in an incompressible moving fluid is lowest where the speed of the fluid is highest.

Figure 1 shows the top view of the cylinder mounted on the cart with the cart sitting on the track. The fan is

blowing air by the cylinder, perpendicularly across the track. If the cylinder was not rotating, the air-speed passing by the front and back of the cylinder would be the same. The pressure in the front and back would be equal and the cart would not move.

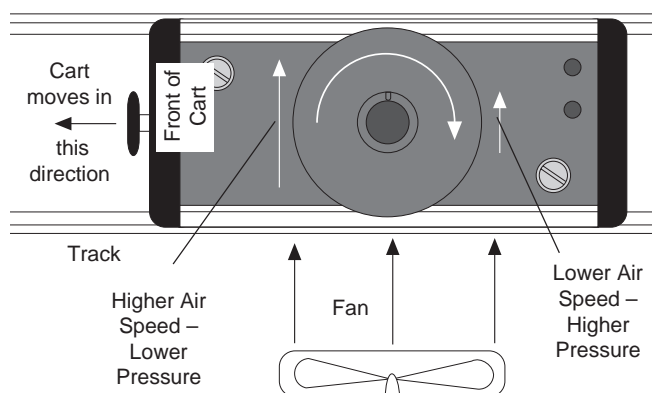

Figure 1A: Top View of Rotating Cylinder

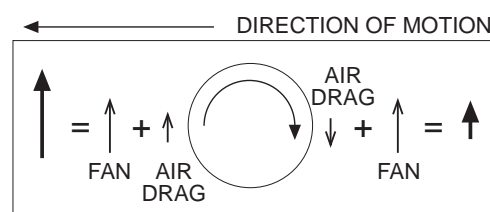

Figure 1B: Air Distribution

When the cylinder is spinning clockwise (ω down) as shown in Figure 1, friction between the cylinder walls and the air causes the speed of the air in front of the cart to become greater than the speed of the air in back of the cart.

According to Bernoulli's Principle, the faster moving air in front of the cart exerts less pressure on the cylinder than the slower moving air in back of the cart. This difference in pressure produces a net force which causes the cart to move forward along the track. If the cylinder is spun in the opposite direction (counterclockwise, ω up), the pressure is less in back of the cart and the cart moves backward.

Demonstration Preparation

- ① Mount the Bernoulli Cart Accessory to the cart with the 2 metric M5X0.8 nylon screws. The base of the accessory fits into the mass tray on the cart.
(►NOTE: When not in use, the two screws can be stored on the base of the accessory.) Remove the two screws from their storage holes and put them through the two holes in the base that line up with the screw holes in the cart.
- ② Tie a knot in one end of the physics string. This will help hold the string in the notch while winding the string onto the pulley.
- ③ Place the cart on the track and level it carefully to make sure the cart will not roll in any preferred direction. Gently push the cart in each direction to see if it rolls to a stop at approximately the same distance in either direction.
- ④ Plug in the fan and place it on the table, directing the air flow perpendicular to the track at the location of the cart.

► NOTE: Most fans work better if they are not too close to the track: A large fan should be further than 50 cm from the track. Check your fan to see if the air is pushed forward from the fan blades rather than radially outward from the fan blades. Fans that push the air radially outward have a “dead” spot in the center and will not work for this demonstration.

Demonstration Procedure

- ① Begin the demonstration with the fan off.
- ② Place the knotted end of the string in the notch in the pulley at the top of the cylinder as shown in Figure 2. When the string is pulled, the string is supposed to detach from the pulley, allowing the pulley to continue spinning freely, without the string attached.
- ③ Wind the string onto the pulley by holding the string with one hand and spinning the cylinder with the other hand. Notice that the label on top of the cylinder shows which way the cylinder will rotate when you pull on the string. Note which way you wound the string so you can wind it the opposite direction when you spin it for the second time.

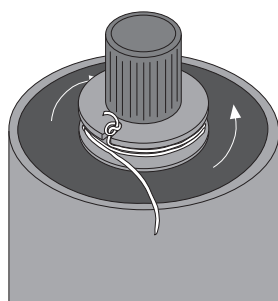

Figure 2:
Placement of string
in pulley

- ④ While holding the top knob with one hand, pull the string firmly and quickly with the other hand. The string should come off the pulley. The cart will remain stationary because the fan is not on.
- ⑤ Turn the fan on. The cart will accelerate along the track until it is out of the air flow. You may move the cart back into the air flow and it will again move along the track in the same direction as before. You may also show that the cart stops moving when the air stops by placing a large card between the fan and the cart to block the air.
- ⑥ Stop the cylinder with your hand and turn the fan off. Wind the string onto the pulley opposite the original direction.
- ⑦ Pull the string and turn on the fan. The cart will now move in the opposite direction.

► NOTE: If the cart seems to move better in one direction than the other, the track is not level.

Storage

Remove the two screws that hold the accessory to the cart and screw them into the two storage holes on the base. Wind the string around the pulley. The Bernoulli Accessory can be stored upright with the base resting flat on a shelf.

Limited Warranty

PASCO scientific warrants this product to be free from defects in materials and workmanship for a period of one year from the date of shipment to the customer. PASCO will repair or replace, at its option, any part of the product which is deemed to be defective in material or workmanship. This warranty does not cover damage to the product caused by abuse or improper use. Determination of whether a product failure is the result of a manufacturing defect or improper use by the customer shall be made solely by PASCO scientific. Responsibility for the return of equipment for warranty repair belongs to the customer. Equipment must be properly packed to prevent damage and shipped postage or freight prepaid. (Damage caused by improper packing of the equipment for return shipment will not be covered by the warranty.) Shipping costs for returning the equipment, after repair, will be paid by PASCO scientific.