

**Instruction Sheet
for the PASCO
Model ME-9457**

Variable Friction Cart Accessory Kit

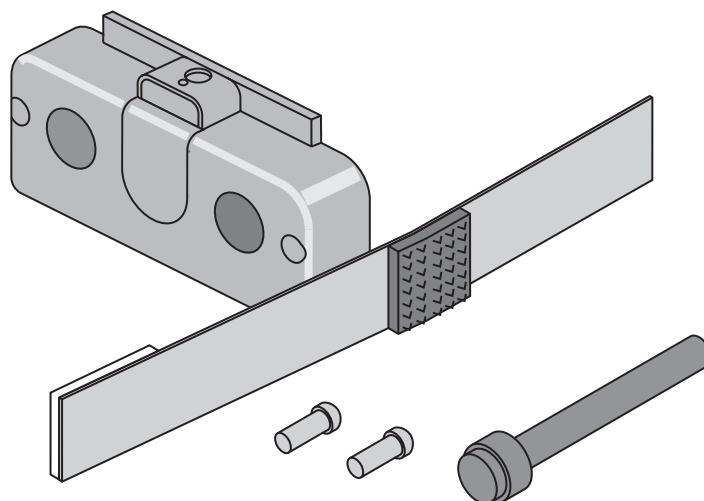

Introduction

The PASCO Model ME-9457 Variable Friction Cart Accessory allows the user to modify their existing PASCO Model ME-9430 Dynamics Cart by attaching a variable friction mechanism. When the accessory is incorporated into the cart, greater flexibility in experiments can be obtained.

Equipment Included

- One Friction Cart End Cap
- One 1/4-20 X 5cm inch black nylon thumbscrew.
- One spring steel strip. On one end of the spring steel strip is a Velcro loop pad; on the other end a piece of adhesive foam tape.
- Two 6-32 X 9.5mm thread forming screws.

Additional Equipment Required:

- #1 Phillips point screw driver

© 1992 PASCO scientific

This instruction sheet written/edited by: D. Griffith

Setup Procedure:

- ① Remove the end cap (that does not have a plunger) from your Dynamics Cart. See Figure 1.

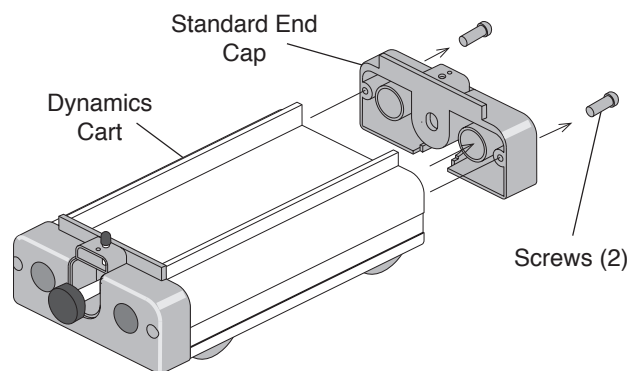

Figure 1 End Cap Removal

► **NOTE:** The screws that secure the end cap to the end of the Dynamics Cart are thread forming screws and may require substantial force to remove and reinstall. A #1 Phillips point screw driver is required.

- ② Replace the standard end cap with a Friction Cart End Cap (included with this kit) using the same screws. If screws are damaged or lost, use the replacement 6-32 X 9.5mm thread forming screws included with this kit.
- ③ Remove the protective cover from the adhesive foam on the spring steel strip (also included with this kit). Locate and firmly apply the spring steel strip to the bottom of the Dynamics Cart as shown in Figure 2.
- ④ Install the 1/4-20 X 5cm thumbscrew into the Friction Cart End Cap as shown in Figure 3.
- ⑤ Adjust the thumbscrew to vary the friction applied to the Dynamics Cart.

The PASCO variable friction cart accessory was adapted from a design by:

Stan Micklavzina
Physics Department
University of Oregon
Eugene, Oregon

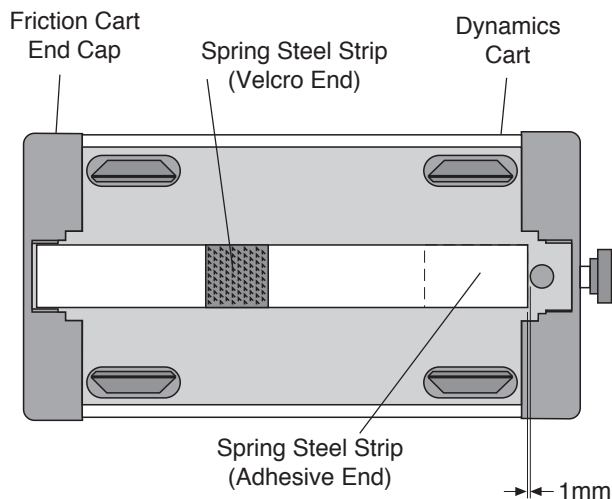

Figure 2 Spring Steel Strip Location

► **NOTE:** The area on the bottom plate (to which the spring steel strip is applied) must be clean. Note the orientation of Dynamics Cart. Use the hole in the bottom plate as a reference.

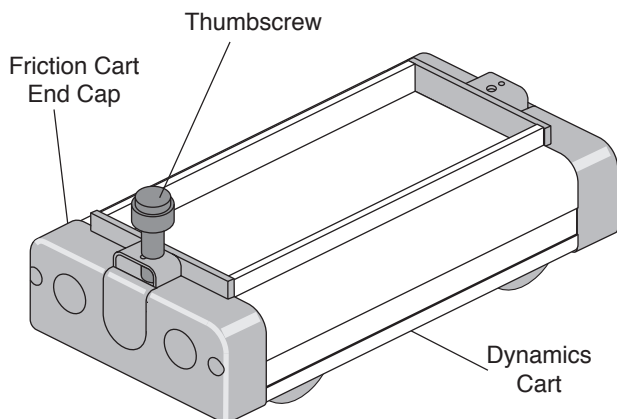

Figure 3 Thumbscrew Assembly

Limited Warranty

PASCO scientific warrants this product to be free from defects in materials and workmanship for a period of one year from the date of shipment to the customer. PASCO will repair or replace, at its option, any part of the product which is deemed to be defective in material or workmanship. This warranty does not cover damage to the product caused by abuse or improper use. Determination of whether a product failure is the result of a manufacturing defect or improper use by the customer shall be made solely by PASCO scientific. Responsibility for the return of equipment for warranty repair belongs to the customer. Equipment must be properly packed to prevent damage and shipped postage or freight prepaid. (Damage caused by improper packing of the equipment for return shipment will not be covered by the warranty.) Shipping costs for returning the equipment, after repair, will be paid by PASCO scientific.