

**Instruction Manual and
Experiment Guide for
the PASCO scientific
Model ME-9283**

012-04944B
2/93

TAPE TIMER

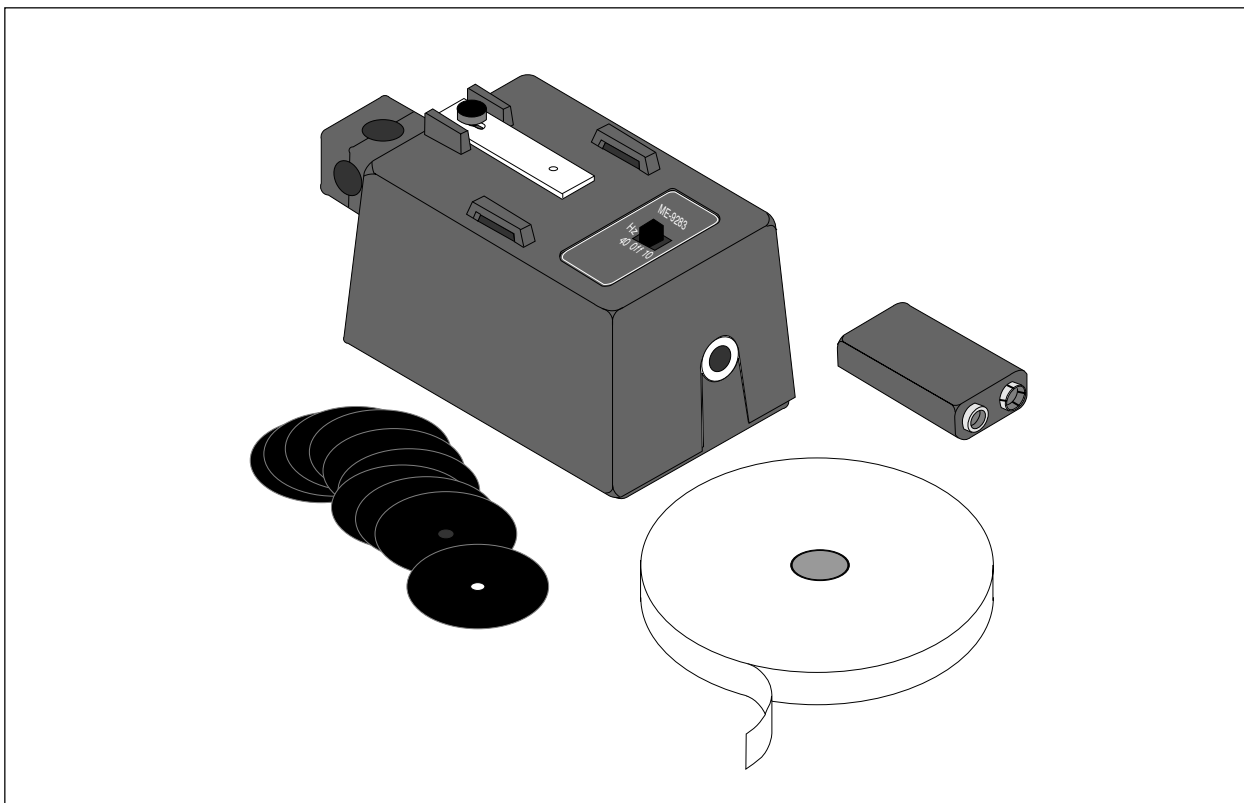

Copyright © January 1993

\$5.00

Table of Contents

Section	Page
Copyright, Warranty, and Equipment Return	ii-iii
How to Use this Manual	1
Introduction	1
Features	2
Equipment	3
Setup and Operation	4
Experiment: Acceleration Due to Gravity	5

Copyright, Warranty and Equipment Return

Please—Feel free to duplicate this manual subject to the copyright restrictions below.

Copyright Notice

The PASCO scientific Model ME-9283 Tape Timer manual is copyrighted and all rights reserved. However, permission is granted to non-profit educational institutions for reproduction of any part of this manual providing the reproductions are used only for their laboratories and are not sold for profit. Reproduction under any other circumstances, without the written consent of PASCO scientific, is prohibited.

Limited Warranty

PASCO scientific warrants this product to be free from defects in materials and workmanship for a period of one year from the date of shipment to the customer. PASCO will repair or replace, at its option, any part of the product which is deemed to be defective in material or workmanship. This warranty does not cover damage to the product caused by abuse or improper use. Determination of whether a product failure is the result of a manufacturing defect or improper use by the customer shall be made solely by PASCO scientific. Responsibility for the return of equipment for warranty repair belongs to the customer. Equipment must be properly packed to prevent damage and shipped postage or freight prepaid. (Damage caused by improper packing of the equipment for return shipment will not be covered by the warranty.) Shipping costs for returning the equipment, after repair, will be paid by PASCO scientific.

Equipment Return

Should the product have to be returned to PASCO scientific for any reason, notify PASCO scientific by letter, phone, or fax BEFORE returning the product. Upon notification, the return authorization and shipping instructions will be promptly issued.

► **NOTE:** NO EQUIPMENT WILL BE ACCEPTED FOR RETURN WITHOUT AN AUTHORIZATION FROM PASCO.

When returning equipment for repair, the units must be packed properly. Carriers will not accept responsibility for damage caused by improper packing. To be certain the unit will not be damaged in shipment, observe the following rules:

- ① The packing carton must be strong enough for the item shipped.
- ② Make certain there are at least two inches of packing material between any point on the apparatus and the inside walls of the carton.
- ③ Make certain that the packing material cannot shift in the box or become compressed, allowing the instrument come in contact with the packing carton.

Address: PASCO scientific
10101 Foothills Blvd.
Roseville, CA 95747-7100

Phone: (916) 786-3800
FAX: (916) 786-3292
email: techsupp@pasco.com
web: www.pasco.com

Introduction

The PASCO Model ME-9283 Tape Timer easily and accurately measures the motion of an object at two pre-calibrated frequencies. A slower setting (10 Hz) lends itself to most dynamics cart experiments, whereas the faster setting (40 Hz) is ideal for free fall experiments.

This timing method is a visual demonstration of speed and acceleration. A moving object pulls a paper tape through the timer which prints dots on the tape at even time intervals. The result is a series of dots in a line on the paper tape representing the position of the object as a function of time. From the dots on the tape, the distance traveled can be measured and the average speed for each time interval calculated.

The tape can be attached to air track carts, dynamics carts, or falling masses.

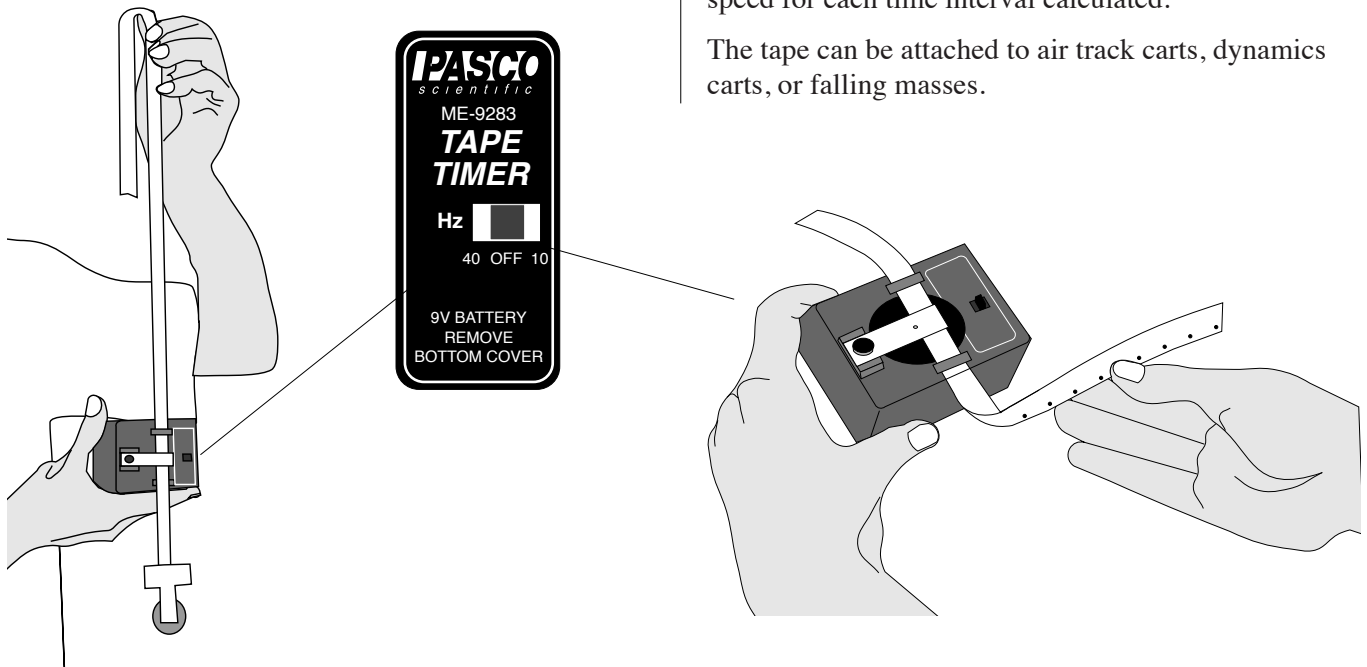

Features

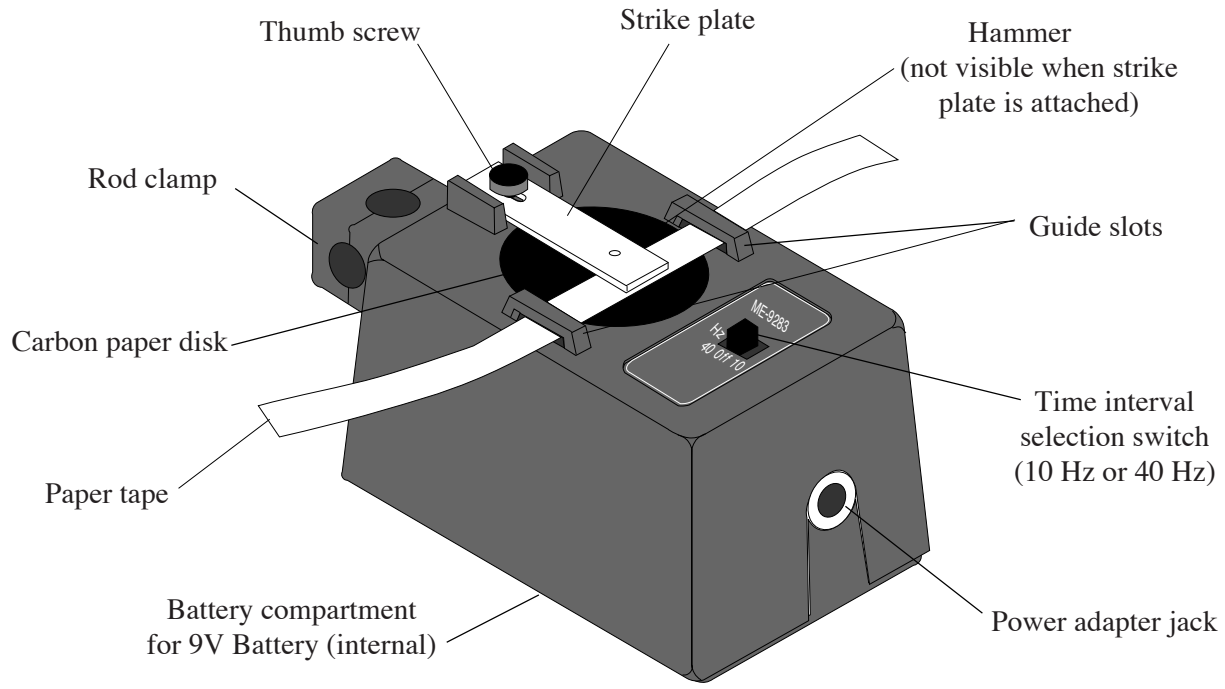

Equipment

The Tape Timer includes the following items

- ME-9283 apparatus
- (10) Carbon paper disks
- Roll of paper tape
- 9 V battery
- Instruction manual

Additional Equipment Available:

- 9 V DC Power Supply/Adapter

Additional supplies required to perform the Experiment:

- Table clamp and rod
- Hooked Mass, 200 g
- Masking tape
- Graph paper

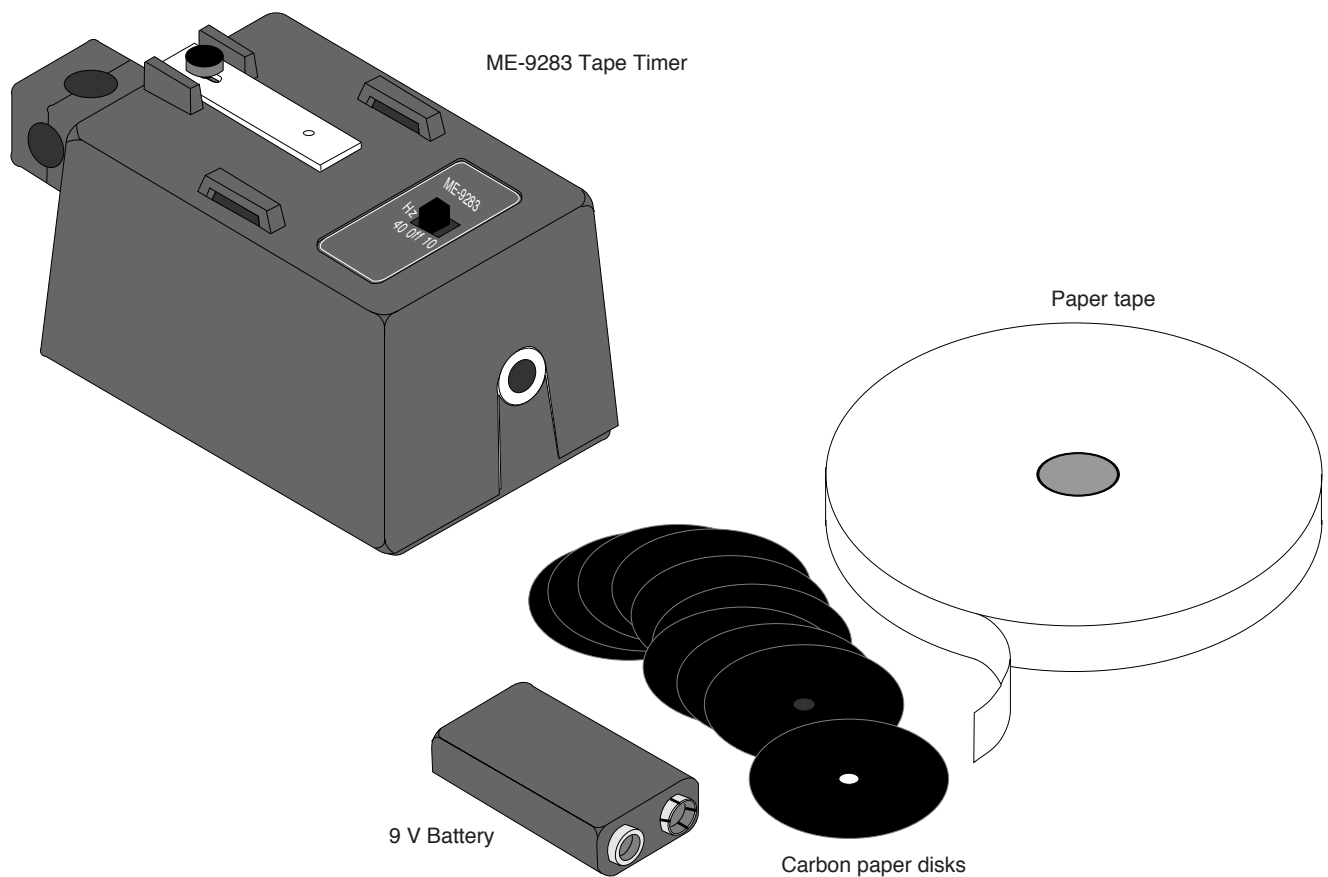

Setup and Operation

Inserting or Replacing the Carbon Paper

- ① Remove the thumb screw and the strike plate from the top of the Tape Timer.
- ② If applicable, remove the used carbon paper and discard it.
- ③ Turn the strike plate over. With the carbon side facing toward the strike plate, center the hole of the new carbon paper disk over the peg on the strike plate.
- ④ Turn both the strike plate and the carbon disk to their original orientation and fasten the strike plate in its place on top of the timer with the thumb screw. Be sure the carbon disk can rotate freely so the hammer will strike the disk in a circular pattern

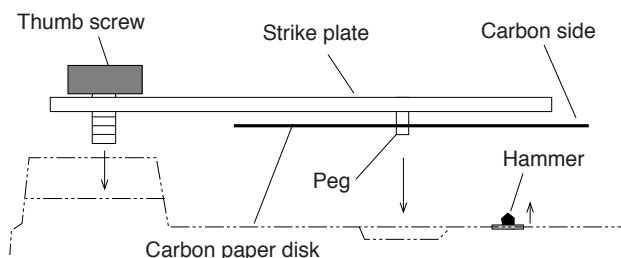

rather than in just one spot.

Inserting the Paper Tape

- ⑤ Cut the paper tape to the length required to span the motion of the object.
- ⑥ Thread one end of the paper tape through both paper guides, between the strike plate and the carbon paper disk. (The paper tape passes over the top of the carbon disk.)
- ⑦ Attach one end of the paper tape to the object and place the apparatus so the tape is in line with the motional direction of the object.

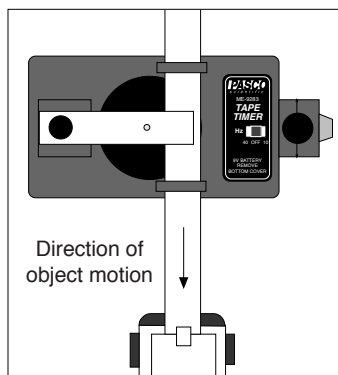

Using the Tape Timer

- ⑧ Turn the selector switch to the desired frequency and set the object in motion. While the object is pulling the tape through the timer, the hammer hits the strike plate at even time intervals. Each hit produces a dot on the paper transferred through the carbon paper.
- ⑨ To analyze the data, record the positions of the dots on the tape. Average speeds can be calculated using the distances between adjacent dots divided by the time interval.

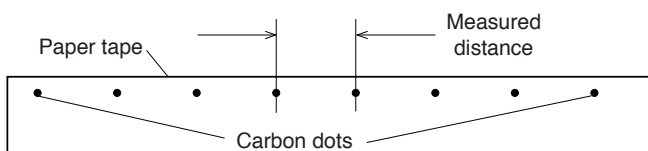

- ⑩ When the dots become faint, move the carbon disk so the hammer will strike it in a new spot. To do so, loosen the thumb screw that holds the strike plate on top of the timer, slide the strike plate to a new position, and tighten the thumb screw. The carbon disk moves with the strike plate.

Battery Replacement

- ① Turn the timer box over and loosen the thumb screw on the bottom of the box.
- ② Remove the bottom of the box. Unclip and replace the 9 V battery with a new one.
- ③ Replace the bottom of the box and tighten the thumb screw.

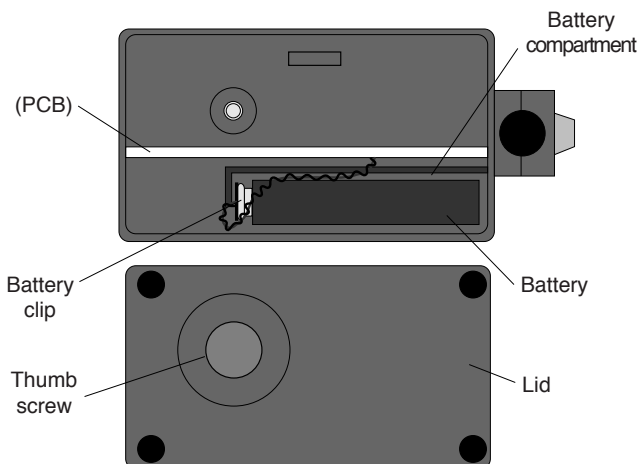

Experiment: Acceleration Due to Gravity

EQUIPMENT NEEDED

- Tape Timer with paper tape
- Hooked mass 200 g
- Table clamp and rod
- Masking tape
- Graph paper

Purpose

The purpose of this experiment is to determine the acceleration due to gravity.

Theory

A mass attached to one end of the tape is allowed to drop. The dots printed on the tape as it passes through the Tape Timer record the position of the mass as a function of time.

To find the acceleration due to gravity, graph the average speed versus time. To calculate the average speeds for each time interval, use

$$\bar{v} = \frac{\Delta x}{\Delta t}$$

The slope of the resulting straight line is equal to the acceleration due to gravity

$$g = \frac{\Delta \bar{v}}{\Delta t}$$

Setup

- ① Clamp the Tape Timer to the edge of a table using the rod and table clamp. Orient the Tape Timer on its side so the tape can pass through the Tape Timer vertically. (See Figure.)
- ② Cut a piece of paper tape as long as the distance between the timer and the floor.
- ③ Make a loop with one end of the paper tape by folding it over and securing it with a piece of tape. Hook the 200 g mass on the loop end of the paper tape.

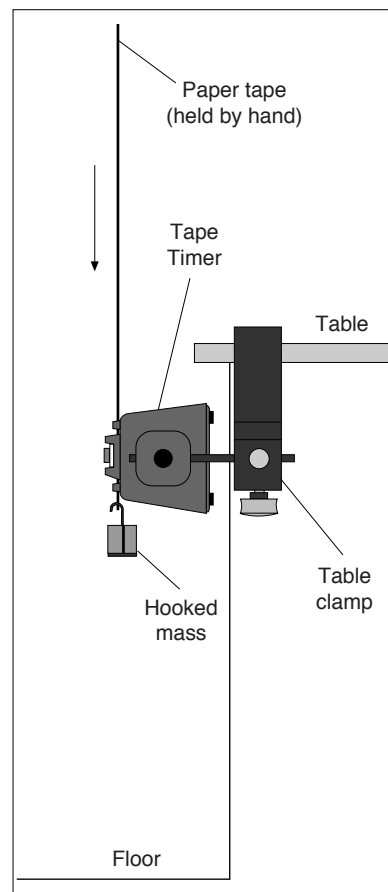

►NOTE: If the mass used is too small, it will not give accurate results because of air drag and friction on the paper tape.

Procedure

- ① Thread the other end of the paper tape through the Tape Timer until the mass is at the level of the Timer.
- ② Hold the paper tape vertically above the Timer and turn on the Timer to 40 Hz.
- ③ Drop the tape, allowing the mass to fall.
- ④ Tape the paper tape to a table and measure the positions of each of the dots. Don't use the first dot because the mass may not have begun to move when the dot was made.

Record the positions in Table 1.

Table 1 Data and Analysis

Position (cm)	Δx (cm)	Avg. v (cm/s)	t (sec)

Analysis

- ① Calculate the distance (Δx) between dots by subtracting the positions of adjacent dots. Record in Table 1.
- ② Calculate the average speed using

$$\bar{v} = \frac{\Delta x}{\Delta t}$$

where Δt is the time between dots.

Since the Tape Timer was set on 40 Hz, it was making 40 dots per second which means that the time between dots is 1/40 second or 0.025 seconds. Record the average speeds in Table 1.

- ③ Write down the time that each average speed occurred in the last column of Table 1. These are the elapsed times, not the time intervals. Assume that the first average speed occurred at time zero. The beginning of the timing is arbitrary since it will not affect the resulting slope of the line.
- ④ Plot the average speed versus time on graph paper.
- ⑤ Draw the best-fit straight line and find its slope.

slope = g = _____

- ⑥ Calculate the percent difference between the slope and the accepted value for g.

% difference = _____

Technical Support

Feed-Back

If you have any comments about this product or this manual please let us know. If you have any suggestions on alternate experiments or find a problem in the manual please tell us. PASCO appreciates any customer feed-back. Your input helps us evaluate and improve our product.

To Reach PASCO

For Technical Support call us at 1-800-772-8700 (toll-free within the U.S.) or (916) 786-3800.

Contacting Technical Support

Before you call the PASCO Technical Support staff it would be helpful to prepare the following information:

- If your problem is computer/software related, note:

Title and Revision Date of software.

Type of Computer (Make, Model, Speed).

Type of external Cables/Peripherals.

- If your problem is with the PASCO apparatus, note:

Title and Model number (usually listed on the label).

Approximate age of apparatus.

A detailed description of the problem/sequence of events. (In case you can't call PASCO right away, you won't lose valuable data.)

If possible, have the apparatus within reach when calling. This makes descriptions of individual parts much easier.

- If your problem relates to the instruction manual, note:

Part number and Revision (listed by month and year on the front cover).

Have the manual at hand to discuss your questions.

