

**Instruction Sheet  
for the PASCO  
Model ME-8957**

# ROTATIONAL ACCELERATION TANK

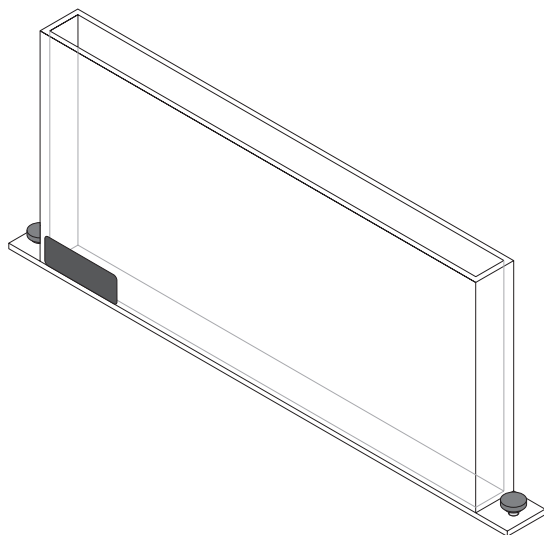

## Introduction

The ME-8957 Rotational Acceleration Tank is an accessory for the ME-8951 Rotating Platform. One of the more difficult concepts in mechanics for students to grasp is the direction of acceleration in circular motion. The Rotational Acceleration Tank can be used to easily show the direction of the centripetal acceleration as well as the effects of rotational motion on a fluid.

Before beginning the rotational demonstration use the Rotational Acceleration Tank or other fluid container to show the effect of linear acceleration on a fluid. Notice that the normal of a plane that is tangent to the curved surface of the liquid points toward the direction of acceleration. See Figure 1.

◆ **NOTE:** The Rotational Acceleration Tank has been designed to stand upright on a desktop or other stable surface.

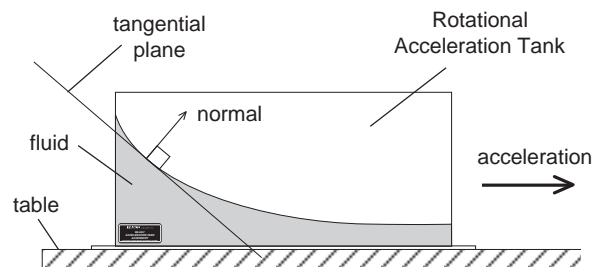

**Figure 1: Linear Acceleration**

## Equipment

- Rotational Acceleration Tank assembly with thumb screw and square nut (2 ea.)

## Additional Equipment Required

- ME-8951 Rotating Platform
- ME-8955 Motor Drive (optional)
- SF-9584 Low Voltage Power Supply (optional)

## Setup

- ① Assemble and level the ME-8951 Rotating Platform. Include the ME-8955 Rotational Motor Drive if desired.
- ② Center the Rotational Tank on the rotating platform, so that the mounting Tabs are aligned with the slot on top of the Rotating Platform. Slide into place and secure with the T-slot attachment screws. See Figure 2.

◆ **NOTE:** Clean the tank between uses if fluids other than water are used.

- ③ Fill the tank no more than half full with the liquid of choice. Water with food coloring is the suggested fluid, but mild solutions of different viscosity can be used.
- ④ Rotate the tank at the desired rate.

© 1995 PASCO scientific

This instruction sheet written/edited by:

Robert Morrison

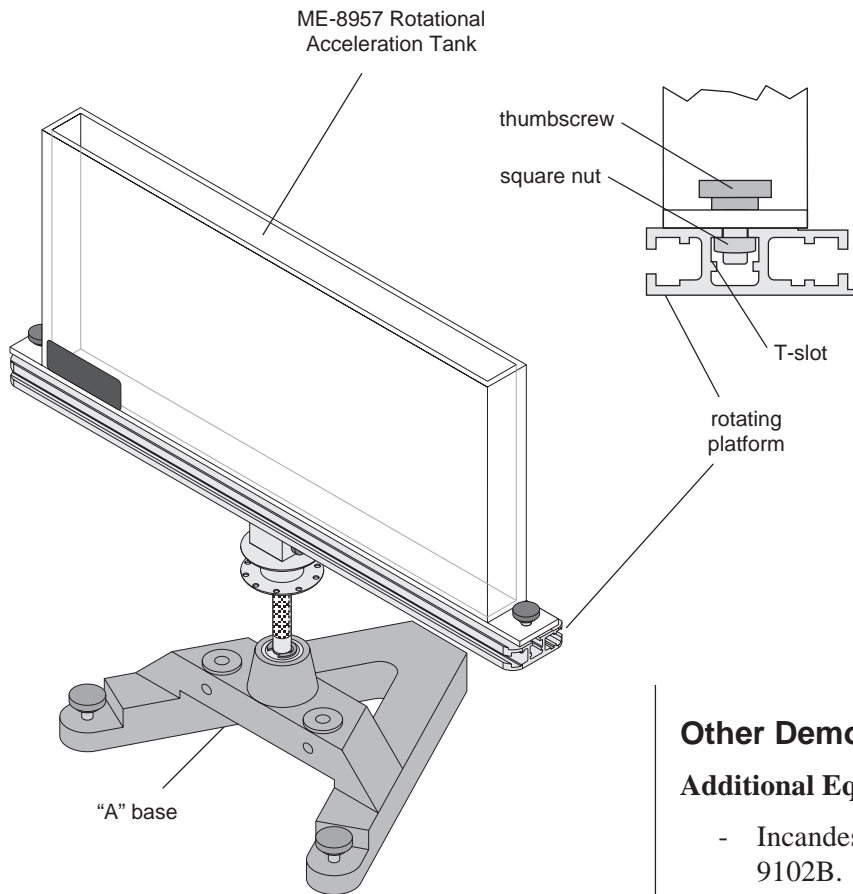
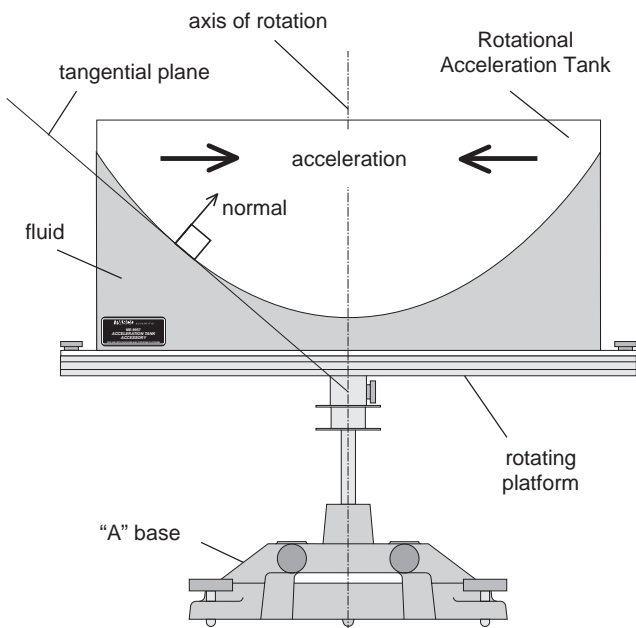

**Figure 2: Rotational Acceleration Tank Setup**

⚠ **CAUTION:** Be careful not to over fill the tank or spin the tank too fast. Spillage will result.

The surface of the water will form a parabolic curve in the tank. The exact shape will correspond to the rate of rotation. Notice that the normal to a plane tangent to the curve of the fluid surface points toward the axis of rotation or direction of acceleration. See Figure 3.

⚠ **CAUTION:** The tank has considerable momentum when it is filled and rotating. Make sure your work space is clear before you rotate the tank. Do not attempt to stop the tank abruptly.



**Figure 3: Rotating Acceleration**

**Other Demonstrations**

**Additional Equipment Required**

- Incandescent Light Source, such as PASCO OS-9102B.

The Rotational Acceleration Tank can also be used to demonstrate reflection and refraction.

- ① Place the tank on the rotating platform, or on a stable desktop and fill the tank with the liquid to be observed.
- ② Place a light source at the desired angle and observe the angle of reflection or refraction. See Figure 4.

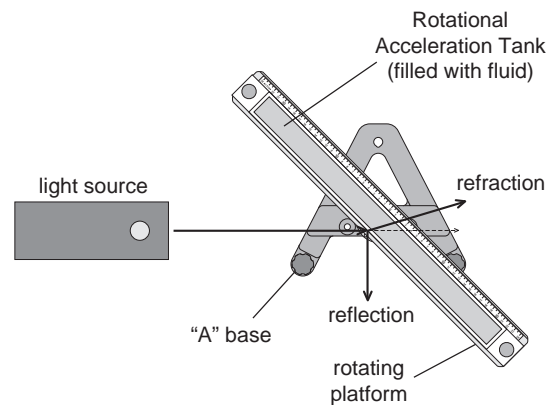
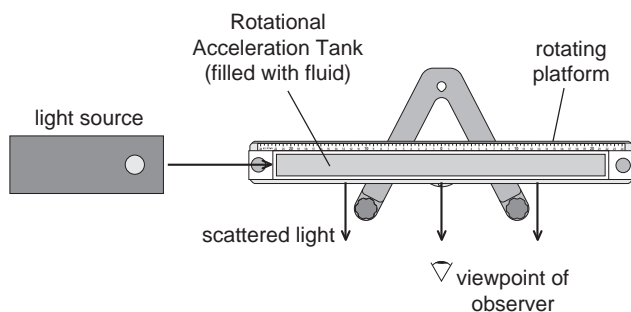

**Figure 4: Angle of Refraction/Reflection**

The Rotational Acceleration Tank can be used to demonstrate why the sky is blue and the sunset is red. When sunlight enters the upper atmosphere the shorter wave lengths of the visible spectrum are scattered in all directions by the molecules of the upper atmosphere. The remaining light passes through. When we observe a portion of the sky, ( not directly between us and the sun) we only see the scattered (blue) light. When the sun sits low on the horizon, Its light must travel through a larger amount of atmosphere. The majority of the shorter wavelength (blue) has been scattered leaving only the longer wavelength light (red).

## Setup

- ① Place the tank on the rotating platform, or on a stable desktop and fill the tank with the liquid to be observed.
- ② Add a small amount of contaminant to the fluid, such as clear dish soap, in the tank to enhance the effect.
- ③ While observing the front of the tank shine a light

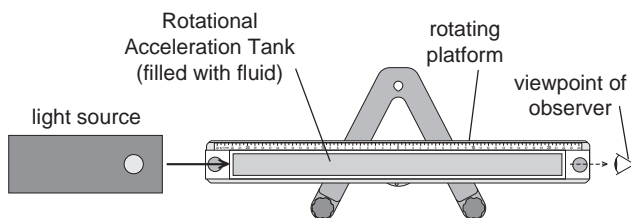

**Figure 5: Blue Sky**

source down the long axis of the tank. See Figure 5.

The scattered light from the tank will have a bluish tint just like the scattered light from the atmosphere.

- ④ Look down the long axis of the tank, toward the light source, and observe the light shining through



**Figure 6: Red Sunset**

the tank. See Figure 6.

The light shining through the tank has a reddish or orange tint just like the sun at sunset.

## Limited Warranty

PASCO scientific warrants this product to be free from defects in materials and workmanship for a period of one year from the date of shipment to the customer. PASCO will repair or replace, at its option, any part of the product which is deemed to be defective in material or workmanship. This warranty does not cover damage to the product caused by abuse or improper use. Determination of whether a product failure is the result of a manufacturing defect or improper use by the customer shall be made solely by PASCO scientific. Responsibility for the return of equipment for warranty repair belongs to the customer. Equipment must be properly packed to prevent damage and shipped postage or freight prepaid. (Damage caused by improper packing of the equipment for return shipment will not be covered by the warranty.) Shipping costs for returning the equipment, after repair, will be paid by PASCO scientific.

## Equipment Return

Should this product have to be returned to PASCO scientific, for whatever reason, notify PASCO scientific by letter or phone BEFORE returning the product. Upon notification, the return authorization and shipping instructions will be promptly issued.

► **NOTE: NO EQUIPMENT WILL BE ACCEPTED FOR RETURN WITHOUT AN AUTHORIZATION.**

When returning equipment for repair, the units must be packed properly. Carriers will not accept responsibility for damage caused by improper packing. To be certain the unit will not be damaged in shipment, observe the following rules:

- ① The carton must be strong enough for the item shipped.
- ② Make certain there is at least two inches of packing material between any point on the apparatus and the inside walls of the carton.
- ③ Make certain that the packing material can not shift in the box, or become compressed, thus letting the instrument come in contact with the edge of the box.

**Notes:**