

**Instruction Sheet
for the PASCO
Model ME-6952**

PAScar/GOcar Accessories

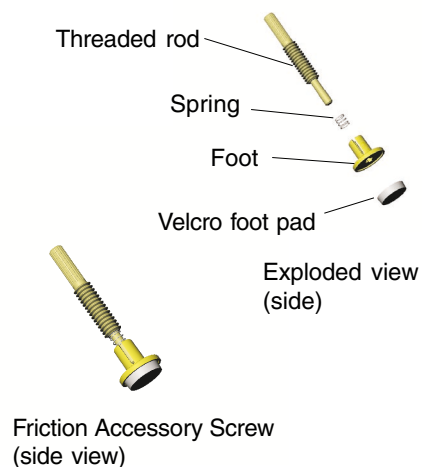
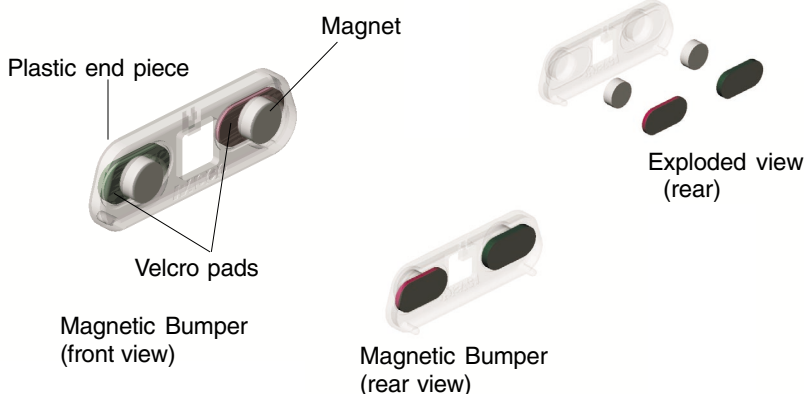

Introduction

The ME-6952 PAScar/GOcar Accessories can be used with PASCO's PAScar (ME-6950) or GOcar (ME-6951). The magnetic bumper piece attaches to the Velcro™ pads on one end of the PAScar and can be used for experiments involving elastic collisions. The friction accessory screw can be threaded from the underside of the PAScar or GOcar. The foot pad on the friction accessory screw rests on any surface, such as a Dynamics Track, and allows the student to introduce additional friction to the experiment.

Equipment Included:

- 1 magnetic bumper with Velcro pads and magnets (part no. 003-07399)
- 1 friction accessory screw with spring (part no. 003-07398)

Additional Equipment Required:

- 1 (or more) PAScar(s) or GOcar(s)

Specifications:

Magnetic bumper: Plastic-molded, polycarbonate, transparent color; includes 2 neodymium magnets and 2 Velcro™ pads

Friction accessory screw: 1/4-20 UNC-2A



CAUTION: The neodymium magnets can be hazardous to electronic or magnetic devices and will erase computer disks. Store the magnets away from computer disks, computer monitors and television sets.

© 2000 PASCO scientific

Attaching the Magnetic Bumper Accessory to the PAScar Model ME-6950

1. Slide Magnetic Bumper Accessory over the PAScar plunger, pressing the plunger in after accessory is in place. Velcro pads on the accessory should align with the Velcro pads on the PAScar. The hooks on the accessory slide into the two small holes on the front bumper of the car (see Figure 1).

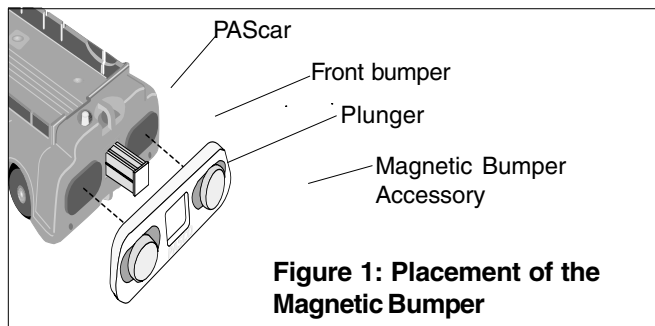

Inserting the Friction Accessory Screw into the PAScar or GOcar

1. Hold the PAScar/GOcar upside down, such that the underside of the car is facing up.
2. Insert the threaded rod into the center hole on the bottom of the car. Rotate the screw clockwise until the foot pad rests against the plastic frame (see Figure 2).

NOTE: The metal rod on the screw will protrude out from the top side of the PAScar or GOcar. To remove the screw, turn the foot pad counterclockwise to loosen the thread and pull out.

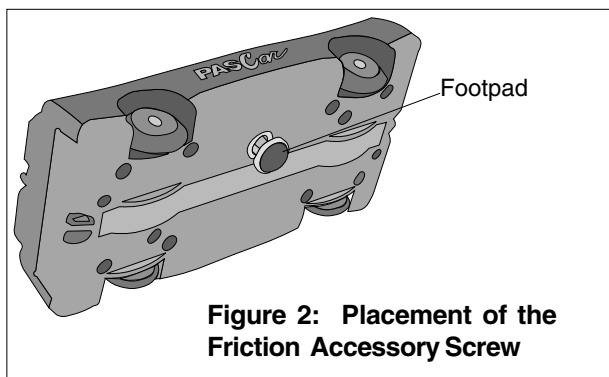

Limited Warranty

PASCO scientific warrants the product to be free from defects in materials and workmanship for a period of one year from the date of shipment to the customer. PASCO will repair or replace, at its option, any part of the product which is deemed to be defective in material or workmanship. The warranty does not cover damage to the product caused by abuse or improper use. Determination of whether a product failure is the result of a manufacturing defect or improper use by the customer shall be made solely by PASCO scientific. Responsibility for the return of equipment for warranty repair belongs to the customer. Equipment must be properly packed to prevent damage and shipped postage or freight prepaid. (Damage caused by improper packing of the equipment for return shipment will not be covered by the warranty.) Shipping costs for returning the equipment after repair will be paid by PASCO scientific.

Address: PASCO scientific
10101 Foothills Blvd.
Roseville, CA 95747-7100

Phone: 1-800-772-8700 (inside the U.S.) or
(916) 786-3800

FAX: (916) 786-3292

e-mail: techsupp@pasco.com

Web site: www.pasco.com



The exclamation point within an equilateral triangle is intended to alert the user of important operating and safety instructions that will help prevent damage to the equipment or injury to the user.