

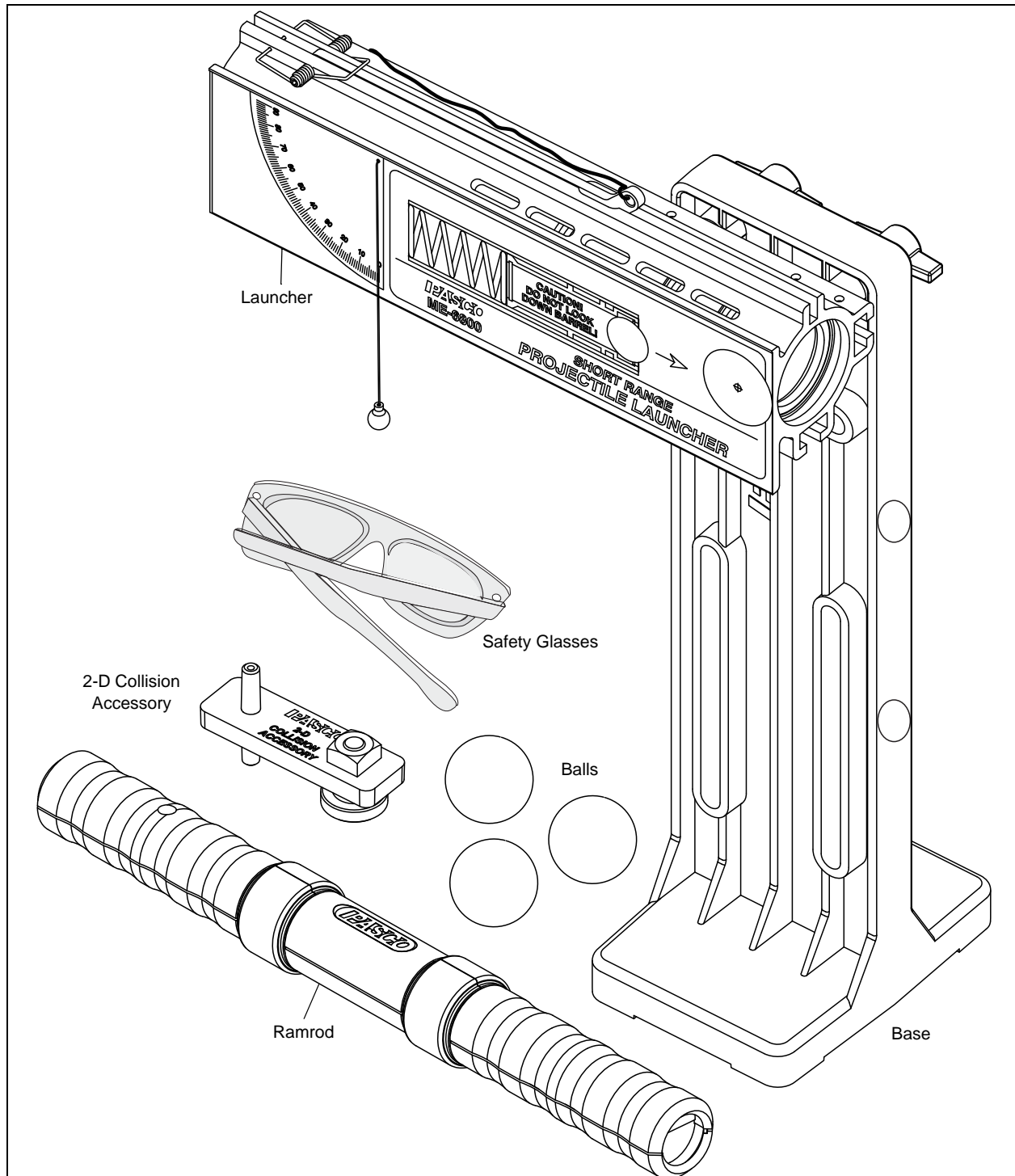

PASCO Short Range / Long Range Projectile Launcher

ME-6800, ME-6801



The cover page shows the PASCO Projectile Launcher. The Launcher comes in a Short Range version and a Long Range version. Each version has three settings for its firing distance: short, medium, and long. The launch angle at the upper launch position can vary from 0 to 90 degrees, and the firing height is fixed for any launch angle. The Launcher can also be mounted in a horizontal position that is height-adjustable. The Launcher is designed to also work with the ME-6831 Ballistic Pendulum. This manual contains seven copy-ready experiments and three demonstrations about projectile motion.

Table of Contents

Introduction	1
Equipment	1
Recommended Equipment	2
General Operation of the Projectile Launcher	3
Installation of the Optional Photogate Bracket.	4
Installation of the Two-Dimensional Collision Attachment.	5
Expectations for the Projectile Launcher	5
EXPERIMENTS	
1. Projectile Motion	7
2. Projectile Motion Using Photogates.	11
3. Projectile Range versus Angle.	15
4. Projectile Path	19
5. Conservation of Energy	23
6. Conservation of Momentum.	27
7. Vary Angle to Maximize Height	31
DEMONSTRATIONS	
8. Do 30° and 60° Launch Angles give the Same Range?	33
9. Simultaneously Fire Two Balls Horizontally at Different Speeds.	35
10. Shoot through Hoops.	37
Teacher's Guide.	39
Technical Support, Warranty, and Copyright.	45

Projectile Launcher

ME-6800, ME-6801

Introduction

The PASCO Projectile Launcher has been designed for projectile motion experiments and demonstrations. The only addition equipment required is a C-clamp for mounting the Launcher to a table or sturdy horizontal surface. The features of the Projectile Launcher include:

- **Launch at Any Angle:** Balls can be launched from any angle from zero to ninety degrees measured from horizontal (zero degrees). The angle is easily adjusted using thumbscrews and the built-in protractor and plumb-bob give an accurate way to measure the angle of inclination.
- **Three Range Settings:** Each version of Projectile Launchers has three range settings. The Short Range Projectile Launcher ranges are approximately 1.2 m, 3 m, and 5 m when the launch angle is 45° . The Long Range Projectile Launcher ranges are approximately 2.5 m, 5 m, and 8 m. The Long Range Launcher has a stronger spring and is useful for large classroom demonstrations.
- **Fixed Elevation Independent of Launch Angle:** The Projectile Launcher pivots at the muzzle end so the elevation of the ball as it leaves the barrel does not change as the angle is varied. The base has two positions for mounting the Launcher. The top set of slots is used when you want to change the launch angle and the bottom two slots are used when you want to fire a ball horizontally into a target such as a catcher on a PASCO Cart or into a Ballistic Pendulum.
- **Repeatable Results:** The piston keeps the ball from rubbing on the inside of the barrel as it travels, so there is no spin on the ball as it launches. When the base is secured to a table with a C-clamp, there is very little recoil. The trigger is pulled with a string to minimize jerking.
- **Barrel Sights and Safety Precautions:** There are sites built-in to the barrel for aiming the Projectile Launcher. View the sites by looking through the back end of the barrel. **WARNING:** Never look down the front of the barrel because it may be loaded. *Safety glasses are provided*, so use them. Look for the yellow indicator through any of the five slots on the top of the barrel because the yellow indicator shows the position of the piston. If the indicator is between the first and second slots (relative to the muzzle end), the piston is not cocked.
- **Computer Compatible:** One or two photogates can be attached to the Projectile Launcher using the ME-6821A Photogate Mounting Bracket. When used with a PASCO interface and data acquisition software, the photogates can measure the muzzle speed of the ball. Use a photogate and the ME-6810 Time of Flight Accessory to measure the time of flight of the ball
- **Compact Storage:** When the barrel of the Launcher is aligned vertically with the base, the Launcher takes up minimal space. The included ramrod and the base have hook-and-pile material that allows the ramrod to be stored on the base.



Wear Safety Glasses

Equipment

The ME-6800 Short Range Projectile Launcher includes the following:

Included Equipment	Part Number
Projectile Launcher and Base (assembled)	ME-6800, ME-6801
Plastic Balls, 25 mm diameter (3)	see ME-6802
2-D (two-dimensional) Collision Accessory	see ME-6802
Ramrod	see ME-6802
Safety Glasses (2 pair)	699-066

Required Equipment	Part Number
C-Clamp, Large	SE-7285

Recommended Equipment	Part Number
Launcher Spares Kit*	ME-6802
Time-of-Flight Accessory	ME-6810
Projectile Catcher Accessory	ME-6815
Photogate Mounting Bracket	ME-6821A
Shoot-the-Target	ME-6853
Photogate Head	ME-9498A
Laser Sight Accessory	OS-8527A

*The ME-6802 Launcher Spares Kit includes: Ramrod (2), Plastic Balls (10-pack), 2-D Collision Accessory (2), Sights (5-pack), Plumb Bob (24-pack), Nylon Thread (1 spool), and Thumbscrews (10).

The ME-6801 Long Range Projectile Launcher includes the same equipment as the Short Range Launcher. The Long Range Launcher has a stronger spring and longer launch ranges and is otherwise the same as the Short Range Launcher.



ME-6802 Launcher Spares Kit

General Operation of the Projectile Launcher

Parts

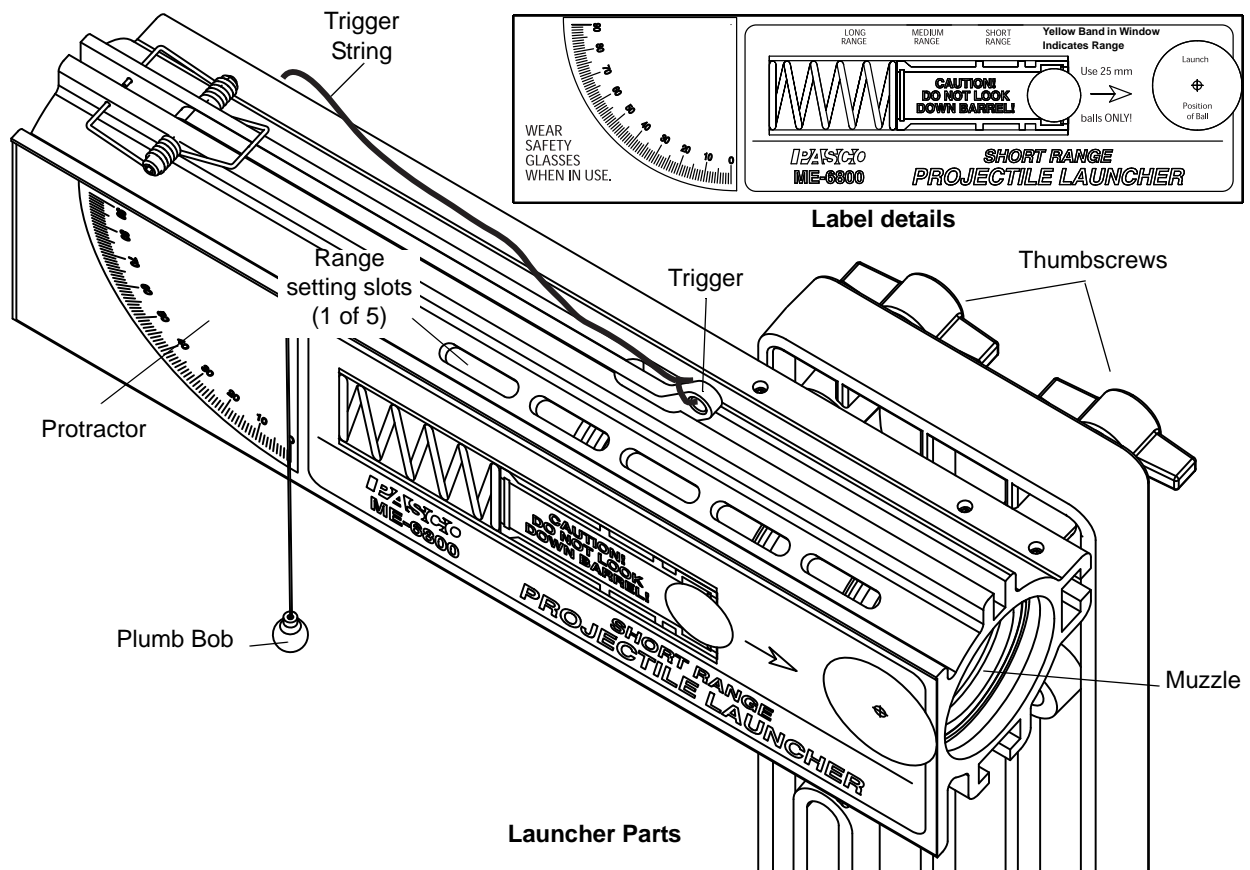

Ready

- Always wear safety goggles when you are in a room where a Projectile Launcher is being used.
- The base of the Projectile Launcher must be firmly clamped to a sturdy table or other surface. When clamping to a table, sometimes it is convenient to have the muzzle end of the Launcher even with an edge of the table so a plumb bob can be used to locate the position of the muzzle with respect to the floor.
- The Projectile Launchers mounted on its base using the hole and curved slot near the top of the base when you want to adjust the Launcher's launch angle. The Launcher can be mounted to the lower two slots in the base if you intend to shoot horizontally, such as into a Projectile Catcher.

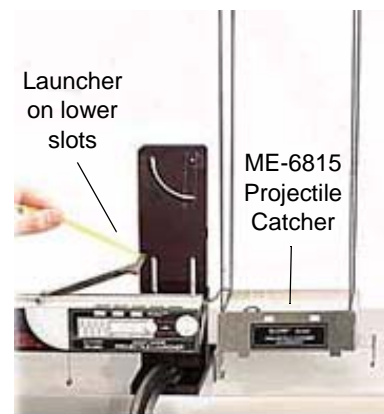

Aim

- The angle of inclination above the horizontal is adjusted by loosening the two thumbscrews and rotating the Launcher barrel to the desired angle. Use the plumb bob and the protractor on the label to select the angle. Tighten both thumbscrews when the angle is set.

- You can 'bore-sight' through the barrel at a target, such as the ME-6853 Shoot-The-Target. Look through the back end of the barrel when the Launcher is not loaded. There are two 'tripod' (three-spoke) sights inside the barrel, one at the end of the barrel and one at the end of the piston (about midway in the barrel). Each sight has a sighting hole at its center. Loosen the thumbscrews and C-clamp and adjust the angle and position of the Launcher to align the centers of both sights on your target. Tighten the thumbscrews and C-clamp when the Launcher is aimed.

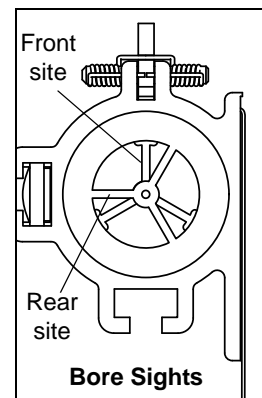

Load

- Place a ball in the muzzle of the Launcher. **NOTE:** Always cock the piston with a ball in the piston. You may damage the piston if you use the ramrod without a ball in the piston.
- Remove the ramrod from its storage place on the base. While looking through the range-setting slots on the top side of the Launcher, push the ball down the barrel with the ramrod until the trigger catches the edge of the piston at the desired range setting. (The trigger will "click" into place.)
- When the yellow indicator tape on the piston is visible in the middle range-setting slot, the piston is in the **SHORT RANGE** position. When the indicator tape on the piston is visible in the next range-setting slot (fourth from the muzzle), the piston is in the **MEDIUM RANGE** position, and when the tape is visible in the last range-setting slot, the piston is in the **LONG RANGE** position.
- Remove the ramrod and return it to the storage place on the base.
- When the Projectile Launcher is loaded, the yellow indicator tape is visible through one of the range-setting slots on the upper side of the barrel. Never look down the barrel! To check whether the Launcher is loaded, look through the range-setting slots on the barrel.

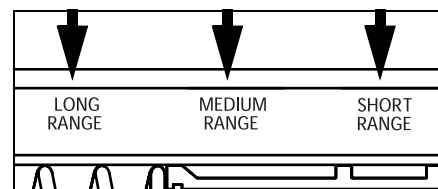

Shoot

- Before shooting the ball, make certain that no one is in the way.
- To shoot the ball, pull straight up on the trigger string that is attached to the trigger. You only need to pull about one centimeter.
- The trigger will automatically return to its initial position after you release the string.

Maintenance and Storage

- The Projectile Launcher does not need any special maintenance.
- Do not oil the Launcher!
- To store the Launcher in the least amount of space, loosen the thumbscrews and align the barrel parallel to the base by adjusting the angle to 90°. Tighten the thumbscrews to hold the barrel in place.

Installing the Optional Photogate Bracket (ME-6821A)

The Photogate Bracket is an optional accessory for mounting one or two photogates on the Projectile Launcher to measure the muzzle speed of the ball.

- Prepare the Photogate Bracket by loosening the thumbscrew near the end of the bracket. Leave the square nut in place on the end of the thumbscrew. Use the smaller (0.75 in) thumbscrews that are stored on the bottom side of the bracket to mount one or two photogates to the bracket

- Align the square nut of the bracket with the T-shaped slot on the bottom of the Launcher barrel and slide the nut into the slot until the photogate nearest to the barrel is as close to the muzzle as possible without blocking the photogate beam. Tighten the bracket thumbscrew to secure the bracket in place.

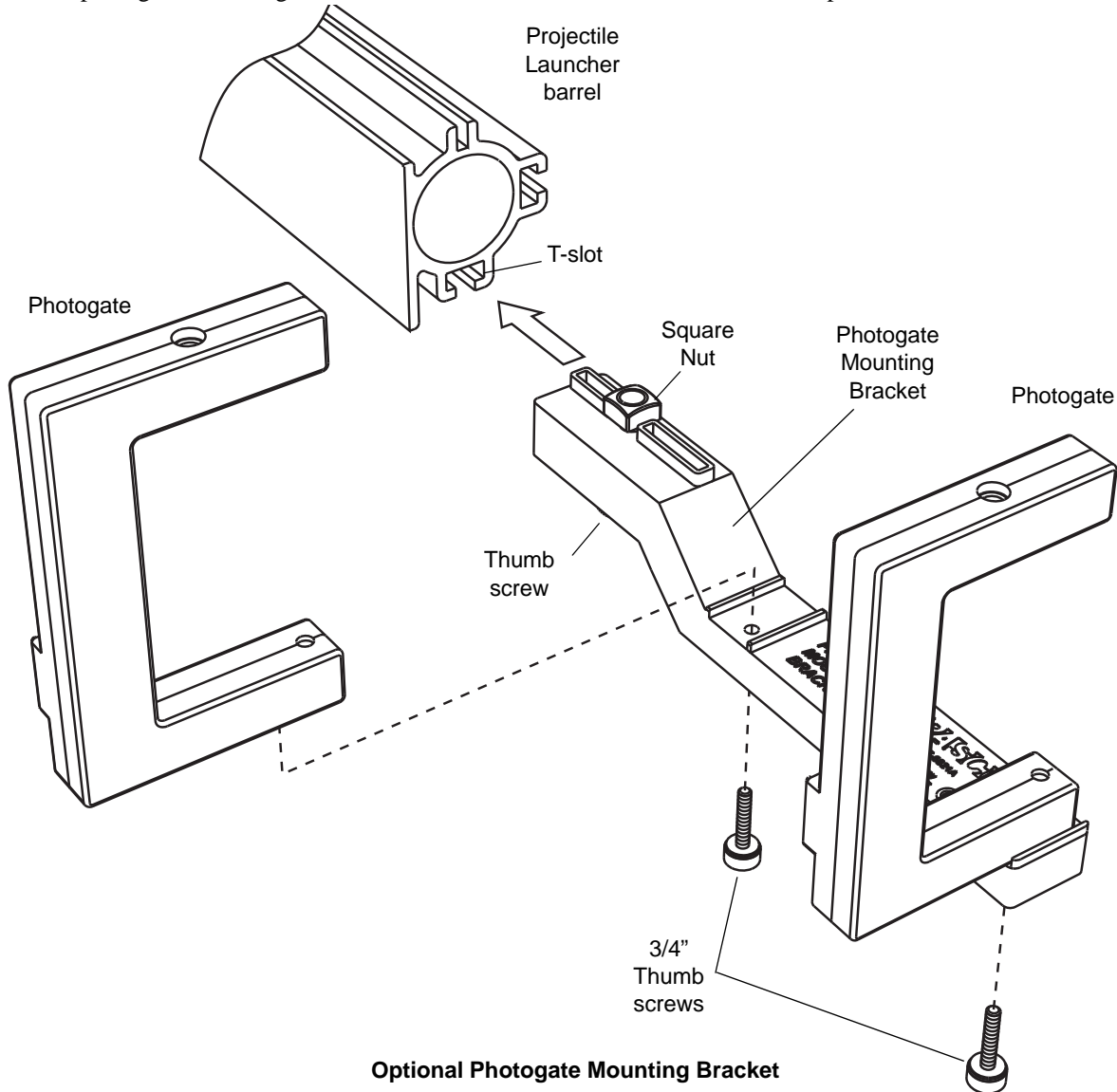

Repairing the Plumb Bob

If the string breaks that holds the plumb bob on the protractor of the Launcher, replace it with an equal length of nylon thread (such as the thread included in the ME-6802 Launcher Spares Kit). Make sure that the replacement string is long enough so that when the Launcher is inclined at an angle of 50°, the string extends well below the corner of the Launcher. Carefully thread the replacement string through the small hole at the vertex of the protractor and tie a triple knot at that end of the string. To put the plumb bob onto the string, thread the string through the hole in the center of the plumb bob and tie a triple knot in that end of the string.

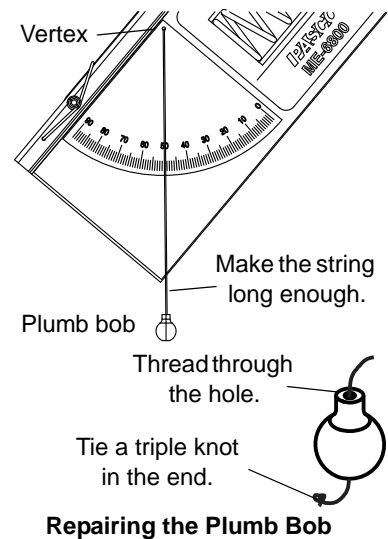

Installing the 2-D (two dimensional) Collision Accessory

Introduction

The 2-D (two dimensional) Collision Accessory is a plastic bar with a thumbscrew and square nut. The bar has a post and you can balance a second ball on the post in front of the muzzle. When the launched ball collides with the second ball, they experience a two dimensional (2-D) collision.

Assembly

To assemble the Collision Accessory, insert the thumbscrew through the hole in the plastic bar and screw the square nut onto the thumbscrew. Leave the square nut loose on the thumbscrew until you install the Collision Accessory onto the Launcher.

To install the Collision Accessory onto the Launcher, slide the square nut into the T-shaped slot on the bottom side of the barrel. Adjust the position of the Collision Accessory and then tighten the thumbscrew. Place a ball on the top of the post, loosen the thumbscrew slightly, and rotate the Collision Accessory to one side or the other until the ball on the post is in a place where it will be hit by the launched ball at the angle that you want.

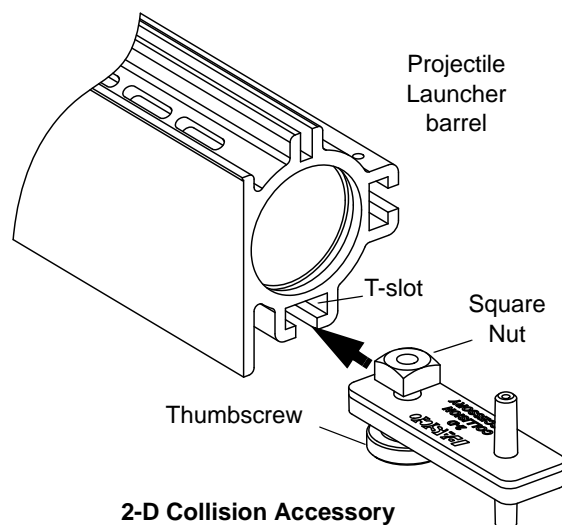

Expectations for the Projectile Launcher

- The muzzle speed will vary slightly with angle. The difference between muzzle speed when shot horizontally versus vertically can be between zero to eight percent, depending on the range setting.
- Although the muzzle end of the Projectile Launcher does not change height with angle, it is about 30 centimeters (12 inches) above table level. If you desire to show that projectiles fired with the same muzzle speed but at complementary angles will have the same range, you need to shoot to a horizontal target that is at the same height as the muzzle.
- The scatter pattern of projectiles with the Projectile Launcher is minimized when the Projectile Launcher is securely clamped to a sturdy table. Any wobble in the table will show up in the data.
- The angle of inclination can be determined to within one-half of a degree.

Exp. 1: Projectile Motion

Equipment Needed

Item	Item
Projectile Launcher and plastic ball	Plumb bob and string
Meter stick	Carbon paper
White paper	Sticky tape

Purpose

The purpose of this experiment is to predict and verify the range of a ball launched at an angle. The initial speed of the ball is determined by shooting it horizontally and measuring the range of the ball and the height of the Launcher.

Theory

To predict where a ball will land on the floor when it is shot from the Launcher at some angle above the horizontal, it is first necessary to determine the initial speed (muzzle velocity) of the ball. That can be determined by shooting the ball horizontally from the Launcher and measuring the vertical and horizontal distances that the ball travels. The initial speed can be used to calculate where the ball will land when the ball is shot at an angle above the horizontal.

Initial Horizontal Speed

For a ball shot horizontally with an initial speed, v_0 , the horizontal distance travelled by the ball is given by $x = v_0 t$, where t is the time the ball is in the air. (Neglect air friction.)

The vertical distance of the ball is the distance it drops in time t given by .

$$y = \frac{1}{2}gt^2$$

The initial speed can be determined by measuring x and y . The time of flight, t , of the ball can be found using

$$t = \sqrt{\frac{2y}{g}}$$

and the initial horizontal speed can be found using $v_0 = \frac{x}{t}$.

Initial Speed at an Angle

To predict the horizontal range, x , of a ball shot with an initial speed, v_0 , at an angle, θ , above the horizontal, first predict the time of flight from the equation for the vertical motion:

$$y = y_0 + (v_0 \sin \theta)t - \frac{1}{2}gt^2$$

where y_0 is the initial height of the ball and y is the position of the ball when it hits the floor. In other words, solve the quadratic equation for t and then use $x = v_0 \cos \theta t$ where $v_0 \cos \theta$ is the horizontal component of the initial speed.

Setup

1. Clamp the Projectile Launcher to a sturdy table or other horizontal surface. Mount the Launcher near one end of the table.
2. Adjust the angle of the Projectile Launcher to zero degrees so the ball will be launched horizontally.

Part A: Determining the Initial Horizontal Speed of the Ball

- Put a plastic ball in the Projectile Launcher and use the ramrod to cock it at the long range position. Fire one shot to locate where the ball hits the floor. At that point, tape a piece of white paper to the floor. Place a piece of carbon paper (carbon-side down) on top of the white paper and tape it in place.
 - When the ball hits the carbon paper on the floor, it will leave a mark on the white paper.
- Fire ten shots.
- Measure the vertical distance from the bottom of the ball as it leaves the barrel to the floor. Record this distance in the Data Table.
 - The “Launch Position of Ball” in the barrel is marked on the label on the side of the Launcher.
- Use a plumb bob to find the point on the floor that is directly beneath the release point on the barrel. Measure the horizontal distance along the floor from the release point to the leading edge of the piece of white paper. Record the distance in the Data Table.
- Carefully remove the carbon paper and measure from the leading edge of the white paper to each of the ten dots. Record these distances in the Data Table and find the average. Calculate and record the total horizontal distance (distance to paper plus average distance from edge of paper to dots).
- Using the vertical distance, y , and the total horizontal distance, x , calculate the time of flight, t , and the initial horizontal speed of the ball, v_0 . Record the time and speed in the Data Table.

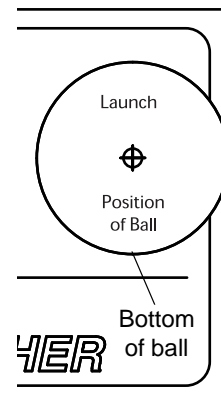

Part B: Predicting the Range of a Ball Shot at an Angle

- Adjust the angle of the Projectile Launcher to an angle between 30 and 60 degrees. Record this angle in the second Data Table.
- Using the initial speed and vertical distance from the first part of this experiment, calculate the new time of flight and the new horizontal distance based on the assumption that the ball is shot at the new angle you have just selected. Record the predictions in the second Data Table.
- Draw a line across the middle of a white piece of paper and tape the paper on the floor so that the line on the paper is at the predicted horizontal distance from the Projectile Launcher. Cover the white paper with carbon paper (carbon side down) and tape the carbon paper in place.
- Shoot the ball ten times.
- Carefully remove the carbon paper. Measure the distances to the ten dots and record the distances in the second Data Table.

Analysis

- Calculate the percent error between the predicted theoretical distance and the actual average distance when shot at an angle.

$$\frac{|theoretical - actual|}{theoretical} \times 100$$

- Estimate the precision of the predicted range. How many of the final 10 shots landed within this range?

Data Table A: Determine the Initial Speed

Vertical distance = _____ Horizontal distance to edge of paper = _____

Calculated time of flight = _____ Initial speed = _____

Trial	Distance
1	
2	
3	
4	
5	
6	
7	
8	
9	
10	
Average	
Total Distance	

Data Table B: Predict the Range

Angle above horizontal = _____ Horizontal distance to edge of paper = _____

Calculated time of flight = _____ Predicted range = _____

Trial	Distance
1	
2	
3	
4	
5	
6	
7	
8	
9	
10	
Average	
Total Distance	

Notes

Exp. 2: Projectile Motion Using Photogates

Equipment Needed

Item	Item
Projectile Launcher and plastic ball	Plumb bob and string
Photogate Head ME-9498A (2)	Photogate Mounting Bracket ME-6821A
PASCO Interface or Timer*	PASCO Data acquisition software*
Meter stick	Carbon paper
White paper	Sticky tape

*See the PASCO web site at www.pasco.com for information about PASCO interfaces, timers, and data acquisition software.

Purpose

The purpose of this experiment is to predict and verify the range of a ball launched at an angle. Photogates are used to determine the initial speed of the ball.

Theory

To predict where a ball will land on the floor when it is shot from the Launcher at some angle above the horizontal, it is first necessary to determine the initial speed (muzzle velocity) of the ball. The speed can be determined by shooting the ball and measuring a time using photogates. To predict the range, x , of the ball when it is shot with an initial speed at an angle, θ , above the horizontal, first predict the time of flight using the equation for the vertical motion:

$$y = y_0 + (v_0 \sin \theta)t - \frac{1}{2}gt^2$$

where y_0 is the initial height of the ball and y is the position of the ball when it hits the floor. Solve the quadratic equation to find the time, t . Use $x = (v_0 \cos \theta)t$ to predict the range.

Setup

1. Clamp the Projectile Launcher to a sturdy table or other horizontal surface. Mount the Launcher near one end of the table.
2. Adjust the angle of the Projectile Launcher to an angle between 30 and 60 degrees and record the angle.
3. Attach the photogate mounting bracket to the Launcher and attach two photogates to the bracket. Check that the distance between the photogates is 0.10 m (10 cm).
4. Plug the photogates into an interface or a timer.

Procedure

Part A: Determining the Initial Speed of the Ball

1. Put a plastic ball in the Projectile Launcher and use the ramrod to cock it at the long range position.
2. Setup the data acquisition software or the timer to measure the time between the ball blocking the two photogates.
3. Shoot the ball three times and calculate the average of these times. Record the data in the Data Table.
4. Calculate the initial speed of the ball based on the 0.10 m distance between the photogates. Record the value.

Data Table: Part A**Table 2.1: Determine the Initial Speed**

Trial	Time
1	
2	
3	
Average Time	
Initial Speed	

Part B: Predicting the Range of a Ball Shot at an Angle

1. Keep the angle of the Projectile Launcher at the original angle above horizontal.
2. Measure the vertical distance from the bottom of the ball as it leaves the barrel to the floor. Record this distance in the second Data Table.
 - The “Launch Position of Ball” in the barrel is marked on the label on the side of the Launcher.
3. Use the vertical distance, the angle, and the initial speed to calculate the time of flight. Record the value.

$$y = y_0 + (v_0 \sin \theta)t - \frac{1}{2}gt^2$$

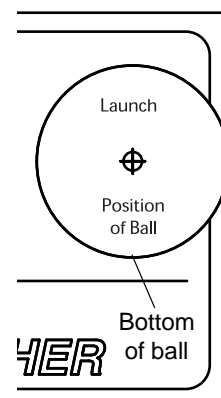

4. Use the time of flight, t , angle, θ , and initial speed, v_0 , to predict the horizontal distance (range, $x = (v_0 \cos \theta) t$). Record the predicted range.
5. Draw a line across the middle of a white piece of paper and tape the paper on the floor so the line is at the predicted horizontal distance. Cover the white paper with carbon paper and tape the carbon paper in place.
6. Use a plumb bob to find the point on the floor that is directly beneath the release point on the barrel. Measure the horizontal distance along the floor from the release point to the leading edge of the piece of white paper. Record the distance in the Data Table.
7. Shoot the ball ten times.
8. Carefully remove the carbon paper and measure from the leading edge of the white paper to each of the ten dots. Record these distances in the Data Table and find the average. Calculate and record the total horizontal distance (distance to paper plus average distance from edge of paper to dots).

Angle above horizontal = _____ Horizontal distance to edge of paper = _____

Calculated time of flight = _____ Predicted range = _____

Data Table: Part B**Table 2.2: Confirm the Predicted Range**

Trial	Distance
1	
2	
3	
4	
5	
6	
7	
8	
9	
10	
Average	
Total Distance	

Analysis

1. Calculate the percent error between the predicted theoretical distance and the actual average distance when shot at an angle.

$$\frac{|theoretical - actual|}{theoretical} \times 100$$

2. Estimate the precision of the predicted range. How many of the final 10 shots landed within this range?

Notes

Exp. 3: Projectile Range versus Angle

Equipment Needed

Item	Item
Projectile Launcher and plastic ball	Plumb bob and string
Meter stick or measuring tape	Box to make landing area same elevation as muzzle
Graph paper	Carbon paper
White paper	Sticky tape

Purpose

The purpose of this experiment is to determine how the range of the ball depends on the launch angle. The angle that gives the greatest range is determined for two cases: for shooting on level ground and for shooting off a table.

Theory

The range is the horizontal distance, x , between the muzzle of the Launcher and the place where the projectile hits, given by $x = (v_0 \cos \theta) t$, where v_0 is the initial speed of the projectile as it leaves the muzzle, θ is the launch angle above horizontal, and t is the time of flight. See the figure.

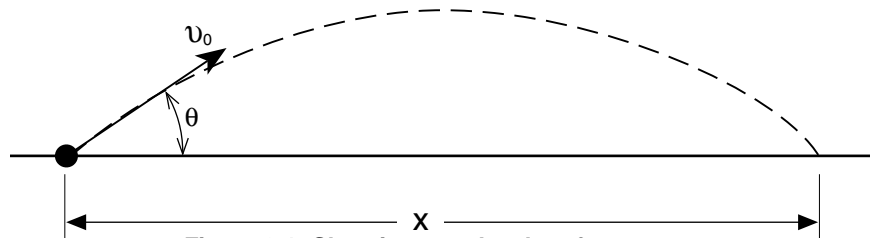

Figure 3.1: Shooting on a level surface

For the case in which the projectile hits on a surface that is the same level as the level of the muzzle of the Launcher, the time of flight of the projectile will be twice the time it takes for the projectile to reach the peak of its trajectory. At the peak, the vertical speed is zero, so:

$$v_y = 0 = (v_0 \sin \theta) - gt_{peak}$$

where v_0 is the initial speed of the projectile. Solving for the time gives an expression for the total time of flight as:

$$t = 2t_{peak} = 2\left(\frac{v_0 \sin \theta}{g}\right)$$

For the case in which the projectile is launched at an angle above horizontal from a table onto the floor, the time of flight is found using the equation for vertical motion:

$$y = y_0 + (v_0 \sin \theta)t - \frac{1}{2}gt^2$$

where y_0 is the initial height of the projectile in the Launcher and y is the vertical position of the ball when it hits the floor.

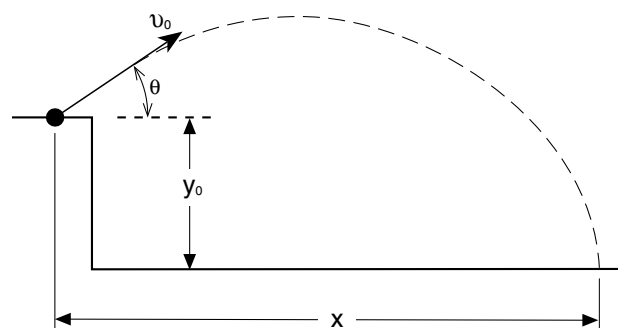
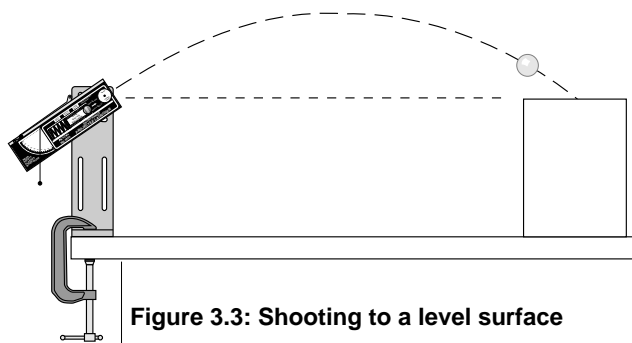

Figure 3.2: Shooting from a table

Setup

1. Clamp the Projectile Launcher to a sturdy table or other horizontal surface. Mount the Launcher near one end of the table, but aim it toward the center of the table rather than away from the table.

2. Adjust the angle of the Projectile Launcher to 10 degrees.
3. Put a plastic ball into the Projectile Launcher and cock it to the medium or long range setting.
- Note: In general, the experiment will not work as well on the short range setting because the muzzle speed is more variable with the change in angle.
4. Fire one shot to locate where the ball hits. Place a box or other horizontal surface at that location so the ball will hit the top of the box at the same level as the muzzle of the launcher.



Procedure

Part A: Shooting to a Level Surface

1. Fire one shot to locate where the ball hits the top of the box. Tape a piece of white paper on the box at this location. Tape a piece of carbon paper (carbon-side down) on top of the white paper.
- When the ball hits the carbon paper it will leave a mark on the white paper underneath.
2. Fire five shots.
3. Use a measuring tape to measure the horizontal distance from the muzzle to the leading edge of the paper. (If a measuring tape is not available, use a plumb bob to find the point on the table that is directly beneath the release point on the barrel and measure the distance along the table from the muzzle to the leading edge of the paper.) Record the distance in the Data Table.
4. Carefully remove the carbon paper. Measure from the leading edge of the paper to each of the five dots and record these distances in the Data Table.
5. Increase the launch angle by 10 degrees and repeat all the steps.
6. Keep repeating for angles up to and including 80 degrees (the complementary angle of 10 degrees).

Data Table: Part A

Table 3.1: Shooting to a Level Surface

Horizontal Distance	Angle	10	20	30	40	50	60	70	80
1									
2									
3									
4									
5									
Average									
Paper distance									
Total distance									

Part B: Shooting Off the Table

1. Turn the Projectile Launcher so it will launch the ball to the floor.

- Repeat the procedure and record the data in the Data Table.

Data Table: Part B

Table 3.2: Shooting off the Table

Horizontal Distance	Angle	10	20	30	40	50	60	70	80
	1								
	2								
	3								
	4								
	5								
Average									
Paper distance									
Total distance									

Analysis

- Find the average of the five distances in each case and record the results in the Data Tables.
- Add the average distance to the distance from the Launcher to the leading edge of the white paper to get the total distance (range) in each case. Record the results in the Data Tables.
- For each Data Table, plot the range versus the angle and draw a smooth curve through the points.

Questions

- From the graph, what angle give the maximum range for each case?
- Is the angle for the maximum range greater or less for shooting off the table?
- Is the maximum range further when the ball is shot off the table or on the level?

Notes

Exp. 4: Projectile Path

Equipment Needed

Item	Item
Projectile Launcher and plastic ball	Movable vertical target board*
Meter stick or measuring tape	Sticky tape
Graph paper	Carbon paper
White paper	

*The target board should be as tall as the distance from the muzzle to the floor.

Purpose

The purpose of this experiment is to determine how the vertical distance a projectile drops is related to the horizontal distance the projectile travels when the projectile is launched horizontally.

Theory

The range is the horizontal distance, x , between the muzzle of the Launcher and the place where the projectile hits, given by $x = v_0 t$, where v_0 is the initial speed of the projectile as it leaves the muzzle and t is the time of flight.

If the projectile is launched horizontally, the time of flight of the projectile will be

$$t = \frac{x}{v_0}$$

The vertical distance, y , that the projectile falls during time, t , is given by

$$y = \frac{1}{2}gt^2$$

where g is the acceleration due to gravity. Substituting for t in the second equation gives

$$y = \left(\frac{g}{2v_0^2}\right)x^2$$

A plot of y versus x^2 will give a straight line with a slope equal to $\frac{g}{2v_0^2}$.

Setup

1. Clamp the Projectile Launcher to a sturdy table or other horizontal surface. Mount the Launcher near one end of the table with the Launcher aimed away from the table.
2. Adjust the angle of the Projectile Launcher to zero degrees so the ball will be launched horizontally.
3. Fire a test shot on medium range to determine the initial position of the vertical target board. Place the target board on the floor so that the ball hits the board near the bottom.

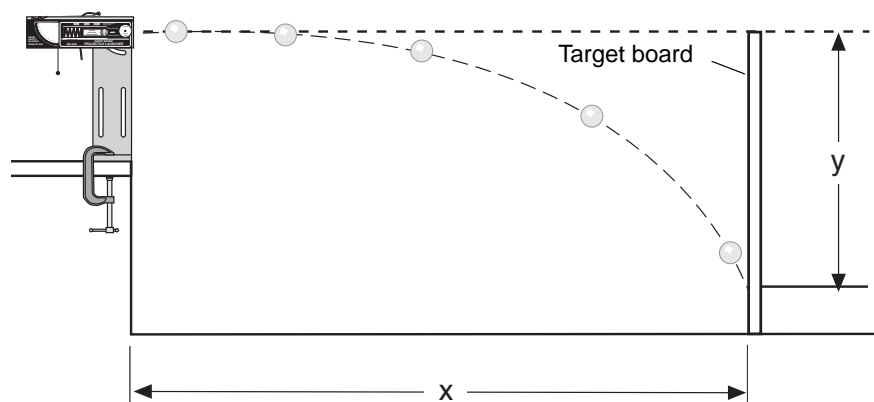

Figure 4.3: Launcher setup

7. Calculate the percent difference between the two initial speeds that were found using the different methods. Record the percent difference in Table 4.2. (To calculate the percent difference, let A be one of the initial speed values and let B be the other initial speed value.)

$$\left| \frac{A - B}{\left(\frac{A + B}{2}\right)} \right| \times 100$$

Data Table 4.2

Table 4.2: Compare Methods for Initial Speed

Item	Value
Slope of graph	
Initial speed from slope	
Time of flight	
Initial speed from x,y	
Percent difference	

Question

1. From the graph, was the best-fit line straight?
2. What does the shape of the best-fit line on the y versus x^2 graph tell you about the relationship of y and x^2 ?
3. If you plotted a graph of y versus x , how would the graph differ from the y versus x^2 graph?
4. What shape is the path of the projectile?

Notes

Exp. 5: Conservation of Energy

Equipment Needed

Item	Item
Projectile Launcher and plastic ball	Plumb bob and string
Meter stick or measuring tape	Sticky tape
White paper	Carbon paper
Photogate Head ME-9498A (2) optional*	Photogate Mounting Bracket ME-6821A optional*

**Use the Photogates and Photogate Mounting Bracket with a PASCO Interface or Timer to measure the initial speed of the ball directly (see Experiment 2).*

Purpose

The purpose of this experiment is to confirm that the initial kinetic energy of a projectile shot straight up is transformed into an equal amount of gravitational potential energy.

Theory

The total mechanical energy of a projectile is the sum of its gravitational potential energy and its kinetic energy. In the absence of friction, total mechanical energy is conserved. When a projectile is shot straight up, the initial gravitational potential energy (GPE) can be defined as zero. The initial kinetic energy (KE) depends on the mass, m , of the projectile and the initial speed:

$$KE = \frac{1}{2}mv_0^2$$

When the projectile reaches its maximum height, h , the speed of the projectile is zero and therefore the kinetic energy is zero. The gravitational potential energy depends on the mass of the projectile and the height:

$$GPE = mgh$$

where g is the acceleration due to gravity. If friction in the form of air resistance is ignored, the initial kinetic energy should equal the final gravitational potential energy.

The initial speed of the projectile must be determined in order to calculate the initial kinetic energy. To calculate the initial speed, v_0 , of a projectile fired horizontally, the horizontal distance travelled by the projectile is $x = v_0t$ where t is the time that the projectile is in the air.

The vertical distance that projectile drops in time, t , is given by

$$y = \frac{1}{2}gt^2$$

The initial speed of the projectile can be calculated by measuring x and y and using y to calculate the time, t . The time of flight of the projectile can be found using

$$t = \sqrt{\frac{2y}{g}}$$

and then the initial speed can be found using

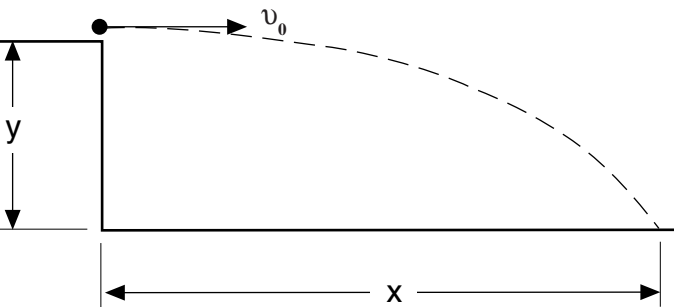

Figure 5.2: Find the initial speed

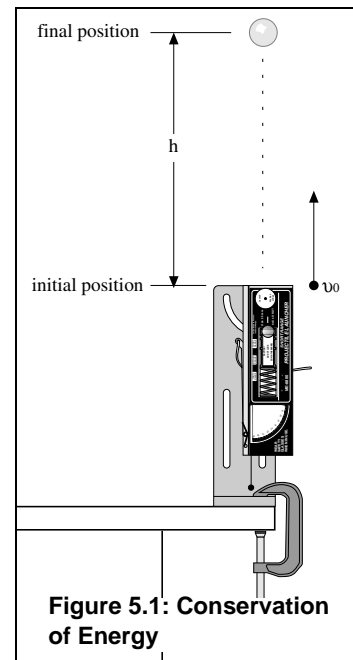

Figure 5.1: Conservation of Energy

Setup

1. Clamp the Projectile Launcher to a sturdy table or other horizontal surface. Mount the Launcher near one end of the table with the Launcher aimed away from the table.
2. Point the Launcher straight up and fire a test shot on medium range to make sure that the ball doesn't hit the ceiling. (If it does, use the short range setting for this experiment or put the Launcher closer to the floor.)
3. Adjust the angle of the Projectile Launcher to zero degrees so the ball will be launched horizontally.

Procedure

Part A: Determine the Initial Speed (without photogates)

1. Put the plastic ball into the Launcher and cock it to the medium range setting. Fire one shot to locate where the ball hits the floor. At that position, tape a piece of white paper to the floor. Place a piece of carbon paper (carbon-side down) on top of the white paper and tape it in place
 - When the ball hits the carbon paper, it will leave a mark on the white paper.
2. Fire ten shots.
3. Measure the vertical distance from the bottom of the ball as it leaves the barrel to the floor. Record this distance in the Table 5.1. Use the distance to calculate the time of flight and record it.
 - The "Launch Position of Ball" in the barrel is marked on the label on the side of the Launcher.
4. Use a plumb bob to find the point on the floor that is directly beneath the release point on the barrel. Measure the horizontal distance along the floor from the release point to the leading edge of the piece of white paper. Record the distance in Table 5.1.
5. Carefully remove the carbon paper. Measure from the leading edge of the white paper to each of the ten dots and record these distances in Table 5.1.
6. Find the average of the ten distances and record it.
7. Using the horizontal distance and the time of flight, calculate the initial speed of the ball. Record the speed.

Data Table 5.1**Table 5.1:**

Item	Value	Item	Value
Vertical distance		Calculated time of flight	
Horizontal distance to edge of paper		Initial speed	

Trial	Distance	Trial	Distance
1		6	
2		7	
3		8	
4		9	
5		10	
		Average	
		Total distance	

Alternate Method for Determining the Initial Speed of the Ball (using photogates)

1. Attach the photogate mounting bracket to the Launcher and attach two photogates to the bracket. Check that the distance between the photogates is 0.10 m (10 cm).
2. Plug the photogates into an interface or a timer.
3. Adjust the angle of the Launcher to 90 degrees (straight up).
4. Put a plastic ball in the Projectile Launcher and use the ramrod to cock it at the medium range setting.
5. Setup the data acquisition software or the timer to measure the time between the ball blocking the two photogates.
6. Shoot the ball three times and calculate the average of these times. Record the data in the Table 5.2.
7. Calculate the initial speed of the ball based on the 0.10 m distance between the photogates. Record the value.

Table 5.2**Table 5.2: Initial Speed Using Photogates**

Trial	Time
1	
2	
3	
Average Time	
Initial Speed	

Part B: Measure the Height of the Ball

1. Adjust the angle of the Launcher to 90 degrees (straight up).
2. Shoot the ball on the medium range setting several times and then measure the maximum height attained by the ball. Record the maximum height in Table 5.3.
3. Determine the mass of the ball and record it in Table 5.3.

Analysis

1. Calculate the initial kinetic energy and record it in Table 5.3.
2. Calculate the final gravitational potential energy and record it in Table 5.3.
3. Calculate the percent difference between the initial kinetic energy and the final gravitational potential energy and record it in Table 5.3.

$$\left| \frac{KE - GPE}{\frac{KE + GPE}{2}} \right| \times 100$$

Table 5.3: Results

Item	Value
Maximum height of ball	
Mass of ball	
Initial Kinetic Energy	
Final Potential Energy	
Percent difference	

Questions

1. How does the initial kinetic energy compare to the final gravitational potential energy?
2. Does friction in the form of air resistance affect the result for the conservation of energy?
3. When the Launcher is cocked, it has elastic potential energy. If energy is conserved, how should the elastic potential energy compare to the initial kinetic energy?

Exp. 6: Conservation of Momentum

Equipment Needed

Item	Item
Projectile Launcher and 2 plastic balls	2-D Collision Accessory
Meter stick or measuring tape	Sticky tape
White paper, large sheet	Carbon paper (2 or 3 sheets)
Protractor	Plumb bob and string

Purpose

The purpose of this experiment is to confirm that momentum is conserved for elastic and inelastic collisions in two dimensions.

Theory

A ball is shot toward another ball that is initially at rest, resulting in a collision after which the two balls move in different directions. In the system consisting of just the balls, both balls are falling under the influence of gravity so momentum is not conserved in the vertical direction. However, there is no net force in the horizontal plane (if air resistance is ignored), so momentum is conserved in the horizontal plane.

Before collision, since all the momentum is in the direction of Ball #1 (m_1), it is convenient to define the x-axis in this direction. Momentum before the collision is:

$$\vec{P}_{before} = m_1 v_0 \hat{x}$$

where v_0 is the initial speed of Ball #1 and \hat{x} is the unit vector in the x-direction. The momenta of the two balls after the collision consists of both horizontal and vertical components, so the momentum after the collision is:

$$\vec{P}_{after} = (m_1 v_{1x} + m_2 v_{2x}) \hat{x} + (m_1 v_{1y} + m_2 v_{2y}) \hat{y}$$

where $v_{1x} = v_1 \cos \theta_1$, $v_{1y} = v_1 \sin \theta_1$, $v_{2x} = v_2 \cos \theta_2$, and $v_{2y} = v_2 \sin \theta_2$.

Since there is no momentum in the y-direction before the collision, there is zero net momentum in the y-direction after the collision. Therefore, t

$$m_1 v_{1y} = -m_2 v_{2y}$$

Equating the momentum in the x-direction before the collision to the momentum in the x-direction after the collision gives:

$$m_1 v_0 = m_1 v_{1x} + m_2 v_{2x}$$

In a perfectly elastic collision, kinetic energy is conserved as well as momentum.

$$\frac{1}{2} m_1 v_0^2 = \frac{1}{2} m_1 v_1^2 + \frac{1}{2} m_2 v_2^2$$

Also, when energy is conserved, the paths of two balls of equal mass will be at right angles to each other after the collision.

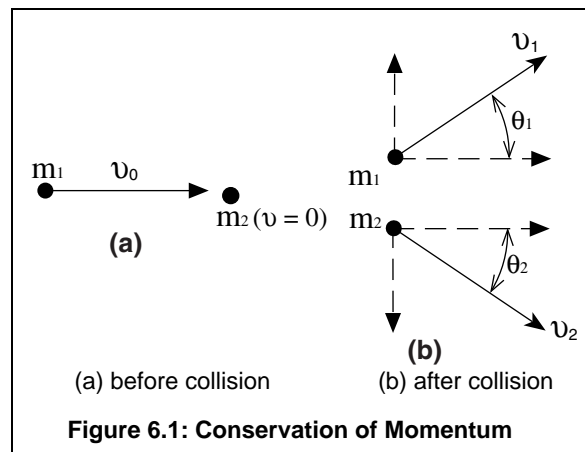

Setup

1. Clamp the Projectile Launcher to a sturdy table. Mount the Launcher near one end of the table with the Launcher aimed inward toward the table.
2. Adjust the angle of the Projectile Launcher to zero degrees so the ball will be launched horizontally onto the table.
3. Cover the table with white paper (such as butcher paper). NOTE: The paper must reach the base of the Launcher.
4. Fire a test shot on the short range setting to make sure that the ball lands on the table. Tape a piece of carbon paper (carbon-side down) over the spot where the ball lands.
5. Mount the 2-D Collision Accessory to the front of the Launcher. Put a target ball on the post ("tee") of the accessory.
6. Loosen the thumbscrew and rotate the 2-D Collision Accessory slightly to one side.
 - The "tee" must be located so that the launched ball does not rebound into the Launcher but does hit the target ball so that both balls land on the table at the same time.
 - Tighten the thumbscrew to hold the accessory in place.
7. Load the Launcher and fire a test shot to check that both balls hit the table at the same time. Tape a piece of carbon paper on the white paper at each spot where the two balls land on the table.

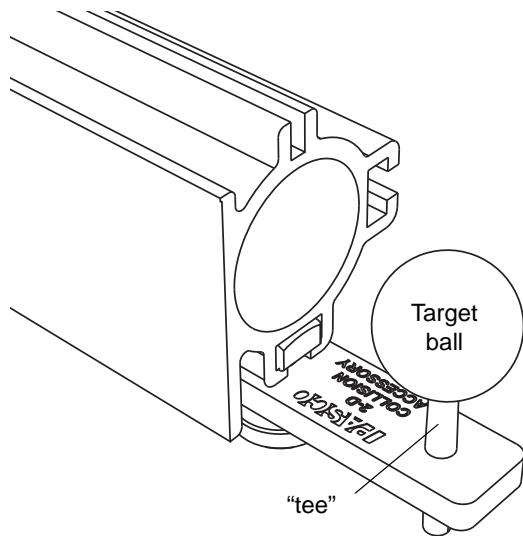

Procedure

A. No Collision

1. Put "ball 1" into the Launcher and cock it to the short range setting. Do not put a target ball on the "tee".
2. Shoot the ball straight ahead and repeat the procedure five times.

B. Elastic Collision

1. Use two balls. Load Ball 1 into the Launcher at the short range setting. Place Ball 2 on the "tee" of the 2-D Collision Accessory.
2. Shoot Ball 1 so it collides with the target ball (Ball 2). Repeat the procedure five times.

C. Inelastic Collision

1. Use two balls. Load Ball 1 into the Launcher at the short range setting. Put a small loop of sticky tape (sticky-side out) on Ball 2 and place it on the "tee".
2. Orient the tape side of Ball 2 so that it will be struck by the launched ball (Ball 1), causing an inelastic collision.
3. Fire a test shot to locate where the two balls hit the table. Tape a piece of carbon paper to the white paper.
4. Shoot Ball 1 and if the two balls stick together but miss the carbon paper, relocate the carbon paper and shoot once more.

- Since the tape does not produce the same inelastic collision each time, it is only useful to record this collision once.
5. Use a plumb bob to locate on the paper the spot directly below the point of contact of the two balls. Mark this spot on the paper as the “point-of-contact” spot. Carefully remove the carbon paper from the white paper.

Analysis

The time of flight for each shot is the same because the vertical distance for each shot is the same. Therefore, the horizontal length of each path is proportional to the speed of the ball. Since the masses are the same, the horizontal length of each path is also proportional to the momentum of the ball.

A. No Collision

1. Draw straight lines from the “point-of-contact” spot to each of the dots made by the ‘no collision’ shots.
2. Measure each straight line and record the length. Find the average of the five lengths and record the length as the “initial x-momentum” in Table 6.1 and Table 6.2. (For example, if the length is 65 cm, record “65” as the value for the “initial x-momentum” but do not include any units.)

B. Elastic Collision

1. Draw a straight line from the “point-of-contact” through the *center* of the group of dots made by the ‘no collision’ shots. (This is the center line from which all of the angles will be measured.)
2. Draw straight lines from the “point-of-contact” spot to each of the dots made by the ‘elastic collision’ shots. (There should be five lines on each side of the center line.)
3. Measure from the “point-of-contact” to each of the dots made by Ball 1. Find the average of the five lengths. Draw a straight line from the “point-of-contact” through the center of the group of dots made by Ball 1.
4. Measure the angle from the centerline to the straight line for Ball 1. Use this angle and the average length of the line for Ball 1 to calculate the x-component for Ball 1 and the y-component for Ball 1. Record the values.
5. Measure from the “point-of-contact” to each of the dots made by Ball 2. Find the average of the five lengths. Draw a straight line from the “point-of-contact” through the center of the group of dots made by Ball 2.
6. Measure the angle from the centerline to the straight line for Ball 2. Use this angle and the average length of the line for Ball 2 to calculate the x-component for Ball 2 and the y-component for Ball 2. Record the values.
7. Add the x-momentum for Ball 1 and the x-momentum for Ball 2 and record the result in Table 6.1 as “Final x-momentum”.
8. Calculate the initial kinetic energy of Ball 1 and the sum of the kinetic energy of Ball 1 and Ball 2 after the collision.
9. Calculate the percent differences.

Table 6.1: Data for the Elastic Collisions

Item	Value	Item	Value	Percent difference
Initial x-momentum, Ball 1		Final x-momentum, Ball 1 + Ball 2		
Final y-momentum, Ball 1		Final y-momentum, Ball 2		
Initial kinetic energy, Ball 1		Final kinetic energy, Ball 1 + Ball 2		

C. Inelastic Collision

1. Draw straight lines from the “point-of-contact” spot to the dots made by the ‘inelastic collision’ shot. (There should be two lines.)
2. Measure from the “point-of-contact” to each of the dots made by the ‘inelastic collision’ shot.
3. Measure the angle from the centerline to the straight line for each dot of the ‘inelastic collision’ shot.
4. Use the angle and the length of the lines for the shot to calculate the x-component and the y-component for each ball in the ‘inelastic collision’ shot. Record the values.
5. After the collision, add the x-momentum for Ball 1 and the x-momentum for Ball 2 and record the result in Table 6.1 as “Final x-momentum”.
6. Calculate the initial kinetic energy of Ball 1 and the sum of the kinetic energy of Ball 1 and Ball 2 after the collision.
7. Calculate the percent differences.

Questions

1. Was momentum conserved in the x-direction for each type of collision?
2. Was momentum conserved in the y-direction for each type of collision?
3. Was kinetic energy conserved for the elastic collision?
4. Was kinetic energy conserved for the inelastic collision?

Exp. 7: Vary the Angle to Maximize the Height

Equipment Needed

Item	Item
Projectile Launcher and plastic ball	Board to protect wall
Meter stick or measuring tape	Sticky tape
White paper, large sheet	Carbon paper (several sheets)
Plumb bob and string	

Purpose

The purpose of this experiment is to find the launch angle that will maximize the height on a vertical wall for a projectile launched at a fixed horizontal distance from the wall.

Theory

When the ball is shot at an angle at a fixed distance, x , from a target such as a vertical wall, the ball hits the wall at a height y given by:

$$y = y_0 + (v_0 \sin \theta)t - \frac{1}{2}gt^2$$

where y_0 is the initial height of the ball, v_0 is the initial speed of the ball as it leaves the muzzle, θ is the angle of inclination above horizontal, g is the acceleration due to gravity, and t is the time of flight. The range is the horizontal distance, x , between the muzzle of the Launcher and the place where the ball hits, given by

$$x = (v_0 \cos \theta)t$$

Solving this equation for the time of flight, t , gives

$$t = \frac{x}{v_0 \cos \theta}$$

Substituting for t in the equation for y gives

$$y = y_0 + x \tan \theta - \frac{gx^2}{2v_0^2 \cos^2 \theta}$$

To find the angle, θ , that gives the maximum height, y , find the first derivative of the equation for y and set it equal to zero. Solve for the angle, θ .

$$\frac{dy}{d\theta} = x \sec^2 \theta - \frac{gx^2 \tan \theta \sec^2 \theta}{v_0^2} = 0$$

Solving for the angle, θ , gives:

$$\tan \theta_{max} = \frac{v_0^2}{gx}$$

Since the second derivative is negative for θ_{max} , the angle is a maximum. To find the initial speed of the ball, use the fixed distance, x , and the maximum height, y_{max} . Solve the y -equation for v_0 and plug in the values for y_{max} , θ_{max} , and x .

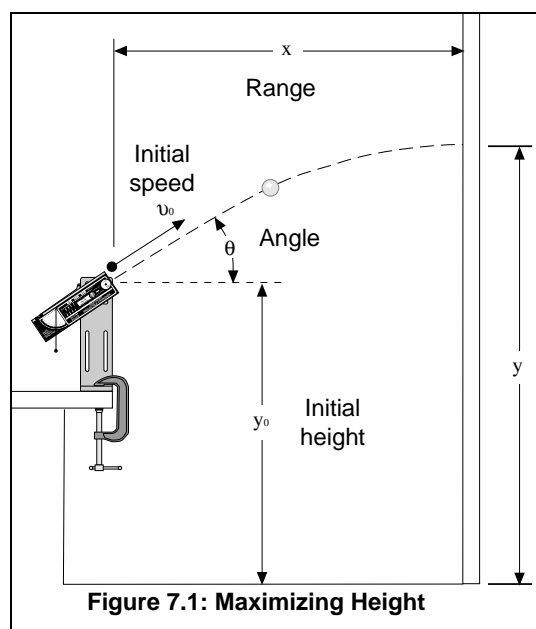

Figure 7.1: Maximizing Height

Setup

1. Clamp the Projectile Launcher to a sturdy table. Mount the Launcher near one end of the table with the Launcher aimed toward a wall about 2 meters from the table.
2. Use a vertical board to protect the wall and cover the board with white paper.
3. Fire a test shot to see where the ball hits the board and tape a piece of carbon paper (carbon-side down) at that position.

Procedure

1. Shoot the ball at various angles and pinpoint which angle gives the maximum height by checking the marks on the white paper. (Move the carbon paper as necessary.)
2. Measure the angle that produces the maximum height and record its value in Table 7.1.
3. Measure the maximum height and record the value in the Data Table.
4. Measure the horizontal distance from the muzzle to the vertical board and record the value.
5. Measure the initial height of the ball where it leaves the muzzle and record the value.

Analysis

1. Calculate the initial speed by solving the y -equation for v_0 and substituting the values for y_{max} , θ_{max} , and x from Table 7.1.

Table 7.1: Data and Results

Item	Value
Measured Angle for Maximum Height	
Maximum Height	
Horizontal Distance	
Initial Height	
Calculated Initial Speed	
Calculated Angle for Maximum Height	
Percent Difference between Angles	

2. Calculate the angle for maximum height using the initial speed calculated in step 1 and the horizontal distance from the wall to the launcher.
3. Calculate the percent difference between the measured angle and the calculated angle. (Let A be one of the angles and B be the other angle).

$$\text{Difference} = \left| \frac{A - B}{\frac{A + B}{2}} \right| \times 100$$

Questions

1. For the angle that gives the maximum height, when the ball hits the wall, has it already reached the peak of its trajectory?
2. For what distance from the wall would height be maximized for a launch angle of 45° ? What would the maximum height be in this case?

Exp. 8 (Demo): Do 30° and 60° Give the Same Range?

Equipment Needed

Item	Item
Projectile Launcher and steel ball	Box to make landing area same height as muzzle

Purpose

The purpose of this demonstration is to confirm that the range of a ball launched at 30° is the same as one launched at 60° if the ball lands at the same height from which it was launched.

Theory

The range is the horizontal distance, x , between the muzzle of the Launcher and the place where the projectile lands, given by $x = (v_0 \cos \theta) t$ where v_0 is the initial speed of the ball as it leaves the muzzle, θ is the launch angle above horizontal, and t is the time of flight.

If the ball lands on a target that is at the same height as the level of the muzzle of the launcher, the time of flight of the ball will be twice the time it takes the ball to reach the peak of its trajectory, when its vertical component of speed reaches zero.

$$t = 2t_{peak} = \frac{2v_0 \sin \theta}{g}$$

where g is the acceleration due to gravity. Substituting for t in the equation for x gives:, and t is the time of flight.

$$x = \frac{2v_0^2 \sin \theta \cos \theta}{g}$$

and using a trigonometry identity gives:

$$x = \frac{v_0^2 \sin 2\theta}{g}$$

The ranges for the angles 30° and 60° are the same since $\sin 60^\circ = \sin 120^\circ$.

Setup

1. Clamp the Projectile Launcher to a sturdy table. Mount the Launcher near one end of the table with the Launcher aimed toward the middle of the table.
2. Adjust the angle of the Launcher to 30°.
3. Put the steel ball into the Launcher and cock it to the medium range or long range setting.

- NOTE: In general, this demonstration will not work as well on the short range setting because the muzzle speed is more variable with the change in angle.
4. Fire a test shot to see where the ball hits. Place the box in front of that location so that the next ball will hit the top of the box.

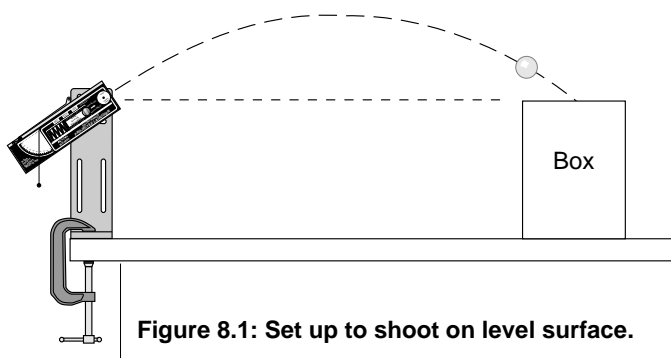

Procedure

1. Shoot the ball at 30° to demonstrate that the ball lands on the box.

2. Change the angle of the Launcher to 60° and shoot the ball again. Call attention to the fact that the ball again lands on the box (confirming that the ranges are the same).
 3. Change the angle to 45° and shoot the ball again to show that the ball now lands further away, missing the box.
 4. Ask the question: What other pairs of angles will have a common range? Will 20° and 70° have the same range? Will 35° and 55° have the same range?
- This demonstration can be done for any two angles that add up to 90° .

Exp. 9 (Demo): Simultaneous Shots at Different Speeds

Equipment Needed

Item
Projectile Launcher (2) and plastic ball (2)

Purpose

The purpose of this demonstration is to confirm that regardless of the initial speed of projectiles fired horizontally, the projectiles will hit the floor at the same time.

Theory

Two projectiles are shot horizontally from the same height, y . The muzzle speeds of the two projectiles are different.

The vertical and horizontal motions of a projectile are independent of each other. The horizontal distance, x , travelled by the projectile depends on the initial speed, v_0 , and the time of flight, t . The distance $x = v_0 t$.

The time of flight depends on the vertical distance that the projectile falls.

$$t = \sqrt{\frac{2y}{g}}$$

where g is the acceleration due to gravity. Since the vertical distance is the same for each projectile, the time of flight is the same for each projectile.

Setup

1. Clamp two Projectile Launchers adjacent to each other on a sturdy table. Mount the Launchers near one end of the table with the Launchers aimed away from the table so the balls will land on the floor.
2. Adjust the angle of the Launcher to 0° so the balls will fire horizontally.

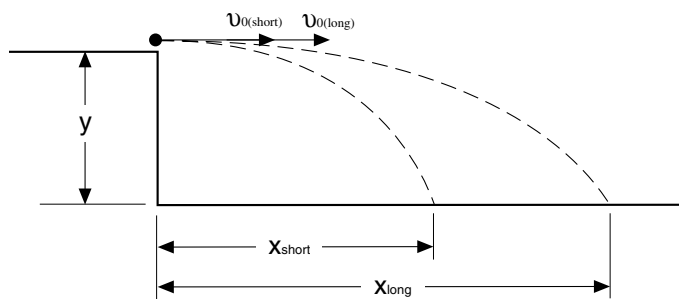

Figure 9.1: Shots fired simultaneously

Procedure

1. Put a plastic ball into each Launcher. Cock one Launcher to the short range setting and cock the other Launcher to the long range setting.
2. Ask the class to be quiet and listen for the balls striking the floor.
 - NOTE: If there is only one click, that means that the balls hit the floor simultaneously.
3. Put both trigger release strings in the same hand and pull them at the same time so that the balls are launched simultaneously.
4. After the balls hit the floor, ask the class if they heard one click or two.

Exp. 10 (Demo): Shooting Through Hoops

Equipment Needed

Item	Item
Projectile Launcher and plastic ball	Ring clamp on stand (5)
Photogate Head ME-9498A (2) optional	Photogate Mounting Bracket ME-6821A optional
Meter stick	Two-meter stick

Purpose

The purpose of this demonstration is to confirm that the part of a projectile is parabolic.

Theory

The range is the horizontal distance, x , between the muzzle of a Launcher and the place where the projectile hits, given by:

$$x = v_0 t$$

where v_0 is the initial speed of the projectile as it leaves the muzzle and t is the time of flight. The vertical position, y , of the projectile at time t is given by:

$$y = y_0 - \left(\frac{1}{2}\right) g t^2$$

where y_0 is the initial height of the projectile and g is the acceleration due to gravity.

Solving the x -equation for t and substituting the expression in the y -equation gives:

$$y = y_0 - \left(\frac{1}{2}\right) g \left(\frac{x}{v_0}\right)^2 = ax^2 + b$$

where “ a ” and “ b ” are constants. The y -equation ($y = ax^2 + b$) describes a parabola.

Pre-Lab

Before the demonstration begins, find the initial speed of the ball. Use two photogates and a photogate mounting bracket with a PASCO Interface or Timer or shoot the ball horizontally and measure x and y . (Use y to calculate the time of flight. See experiments 1 and 2.)

Setup

1. Clamp the Projectile Launcher to a sturdy table near one end of the table with the Launchers aimed away from the table so the balls will land on the floor.
2. Adjust the angle of the Launcher to 0° so the balls will fire horizontally.

Procedure

1. Measure and record the initial height, y_0 , of the ball at muzzle level.

- Calculate and record the horizontal and vertical positions of the ball each 1/10 second until the vertical position is zero.

Table 10.1: X- and y-positions

t (sec)	$x = v_0 t$ (cm)	$y = y_0 - (1/2)gt^2$ (cm)
0.1		
0.2		
0.3		
0.4		
0.5		

- Lay the two-meter stick on the floor in a straight line away from the Launcher. Remove the back mounting screw from the Launcher base so that the back of the Launcher can rotate upward. Look through the Launcher at the end of the two-meter stick. Adjust the end of the stick until the end is aligned with the sites in the Launcher and the stick is along the path of the ball when it is fired.
- Starting at the muzzle of the Launcher, measure off each set of x and y distances and place a ring clamp on a stand at each position corresponding to one-tenth of a second (see Figure 10.1).
- Shoot the ball through the rings.
- Ask the class: What shape of curve is formed by the rings? What is the path of the projectile?

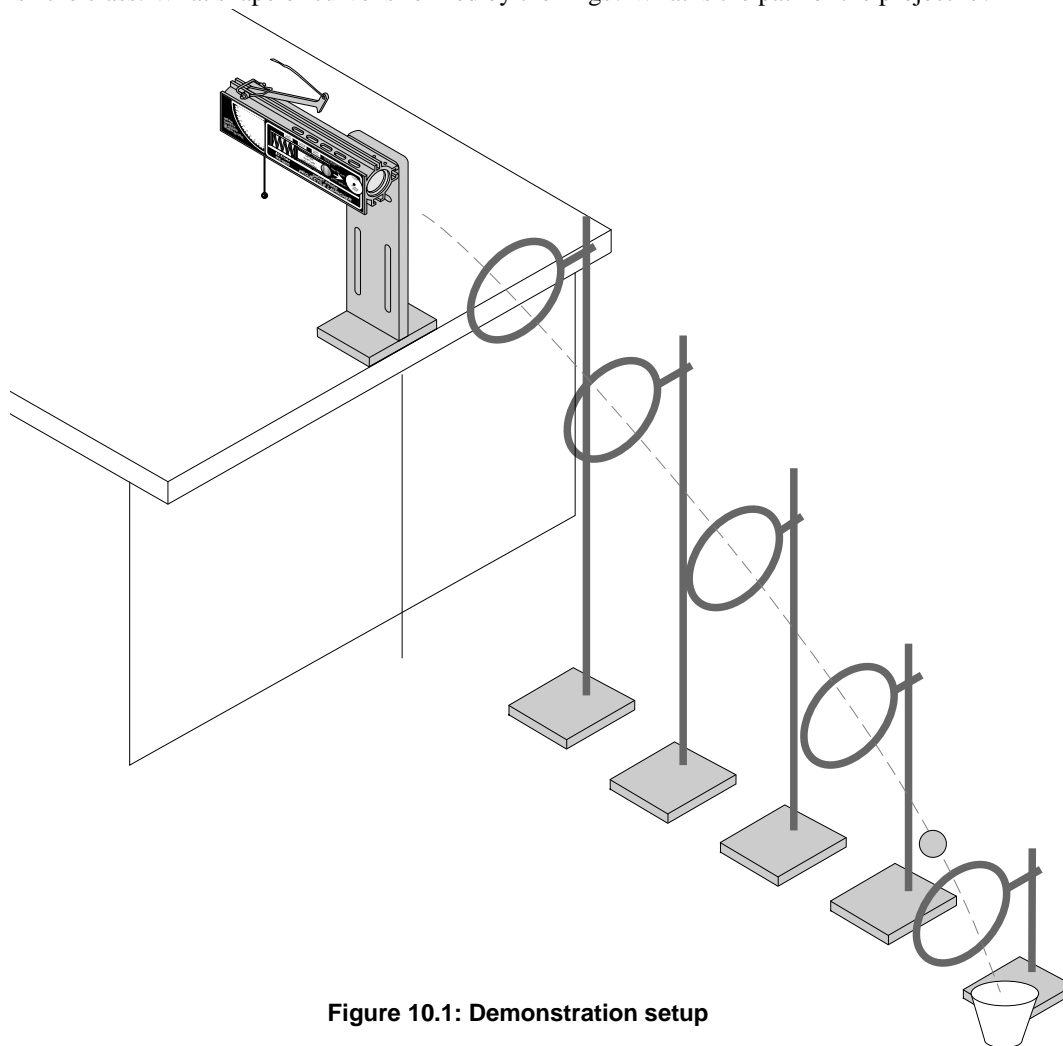

Figure 10.1: Demonstration setup

Teacher's Guide

Exp. 1: Projectile Motion

NOTE: For best results, make sure that the Launcher is securely clamped to a sturdy table. Any movement of the Launcher will result in inconsistent data.

The muzzle speed of the Launcher tested was 6.5 m/s (on the long range setting).

To find the range at the chosen angle, it is necessary to solve the quadratic equation given in the Theory section. The solution is:

$$t = \frac{v_0 \sin \theta + \sqrt{(v_0 \sin \theta)^2 + 2g(y_0 - y)}}{g}$$

Analysis

1. The difference depended on the angle at which the Launcher was fired. The table gives typical results: range

Angle	Predicted Range	Actual Range	Percent Error
30	5.22	5.19	0.57%
45	5.30	5.16	2.64%
60	4.35	4.23	2.87%
39	5.39	5.31	1.48%

NOTE: The maximum angle is not 45° in this case. The range at 60° is not equal to the range at 30°. This is because the initial height of the ball is not the same as the impact point. The maximum range for this setup (with the Launcher 1.15 m above ground level) was calculated to be at 39°. This was verified experimentally.

2. Answers will vary depending on the method for estimating the precision. The primary source of error is ignoring the effect of air resistance.

Exp. 2: Projectile Motion Using Photogates

Except for the method of determining initial speed, this experiment is identical to experiment 1.

Exp. 3: Projectile Range Versus Angle

Procedure

- Shooting off a level surface:

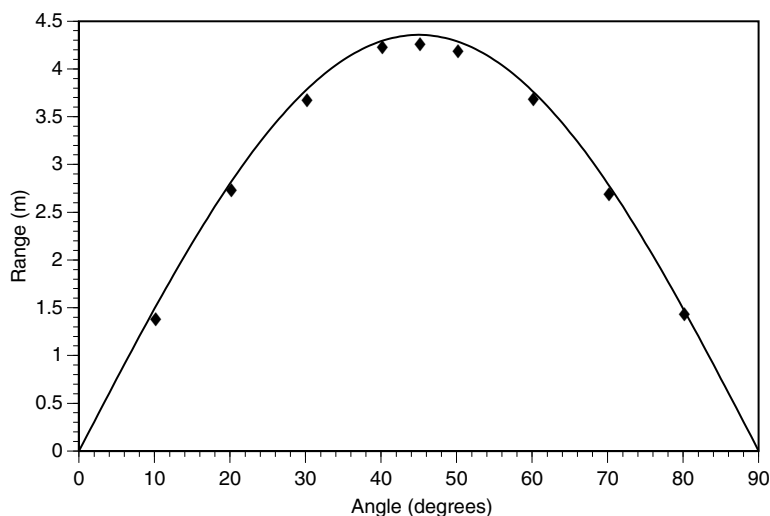

- Shooting off a table:

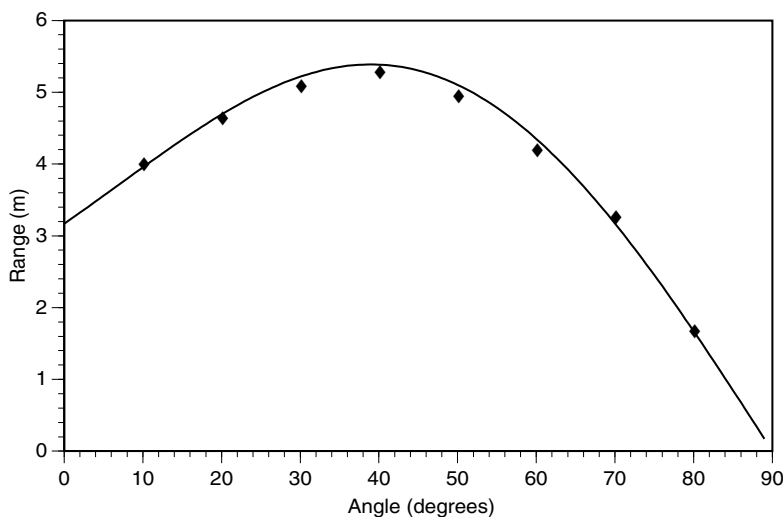

- NOTE: The curves show the calculated ranges in each case. The data points are the actual measured ranges.

Questions

- On a level surface, the maximum range is at 45° . For a non-level surface, the angle of maximum range depends on the initial height of the projectile. For the experimental setup, with an initial height of 1.15 m, the maximum range is at 40° (versus the theoretical value of 39°).
- The angle of maximum range decreases with table height.
- The maximum distance increases with table height.

Exp. 4: Projectile Path

Analysis

- Alternately, measure your distances from the ground up.

2. Vertical distances were measured from the ground up for this graph. The intercept is the height of the launcher above the ground when done this way.

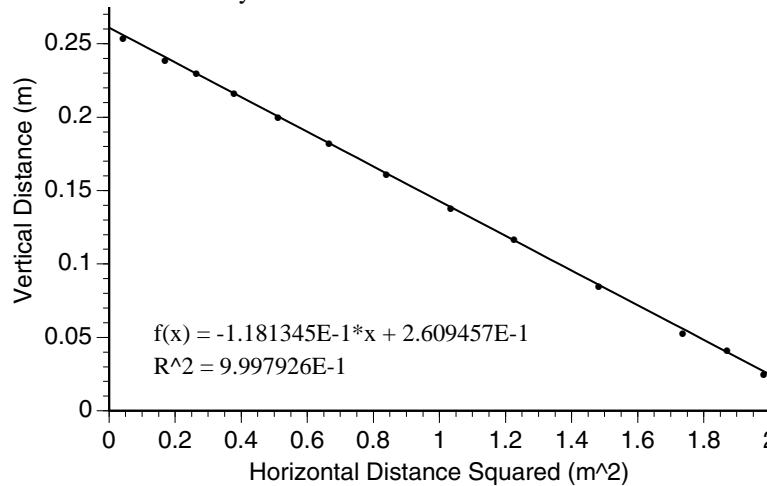

3. The slope (measuring from the ground) is -0.118 for this example. Measuring down from the initial height will give the same value, except positive.) In either case, the slope is:

$$\frac{g}{2v_0^2}$$

4. The slope calculated here gives us an initial speed of 6.44 m/s. This compares favorably with the speed calculated in experiments 1 and 2.

Questions

1. Yes. This tells us that y is a function of x².
2. A plot of y versus x would be parabolic instead of linear.
3. The projectile moves in a parabolic curve (if air resistance is neglected).

Exp. 5: Conservation of Energy

Analysis

1. Using the photogate method, the initial speed of the ball was found to be 4.93 m/s (for the short range launcher at the medium range setting). The ball mass was 9.6 g, so the total kinetic energy was 0.117 J.
2. The ball reached an average height of 1.14 m (above the muzzle). The gravitational potential energy was 0.107 J.
3. The energy difference was 8.5% of the original kinetic energy.

Exp. 6: Conservation of Momentum in Two Dimensions

Setup

- If possible, use medium range setting instead of the short range setting. The medium range setting gives more predictable results than the short-range setting.

Analysis

- Results for the x component of momentum should be within 5% of initial values. The total y component should be very small compared to the x component.

Questions

1. Momentum is conserved on both axes.
2. Kinetic energy is nearly conserved in the elastic collision. There is some loss of energy which indicates that the collision is not perfectly elastic.
3. Momentum is conserved for the inelastic collision, but kinetic energy is not conserved.
4. The angle should be nearly 90° .
5. In the inelastic case, the angle will be less than in the elastic case. The exact angle will depend on the degree of inelasticity, which will depend on the type and amount of tape used.

Exp. 7: Vary the Angle to Maximize the Height**Procedure**

1. You should be able to measure the angle of maximum height to within $\pm 2\%$.
2. Measure the distance to the front edge of the ball.
3. Measure the initial height to the center of the ball.

Analysis

1. The initial speed should be close to the initial speed determined by other methods. You may wish to determine the initial speed by the method in experiment 1, and use that value in your calculations for the rest of the experiment.
2. Measured value and calculated value should agree to within 3%.

Questions

1. The ball will have passed its peak by the time it reaches the wall. To show this, take the derivative of y with respect to x :

$$y = y_0 + x \tan \theta_{max} - \frac{gx^2}{2v_0^2 \cos^2 \theta_{max}}$$

$$\frac{dy}{dx} = \tan \theta_{max} - \frac{gx}{v_0^2 \cos^2 \theta_{max}}$$

- substitute

$$\theta_{max} = \tan^{-1} \left(\frac{v_0^2}{gx_{max}} \right)$$

$$\frac{dy}{dx} = \frac{v_0^2}{gx_{max}} - \frac{gx}{v_0^2 \cos^2 \left(\tan^{-1} \left(\frac{v_0^2}{gx_{max}} \right) \right)}$$

- Substitute

$$\cos \left(\tan^{-1} \left(\frac{a}{b} \right) \right) = \frac{b}{\sqrt{a^2 + b^2}}$$

- and simplify:

$$\frac{dy}{dx} = \frac{v_0^2}{gx_{max}} - \frac{gx}{v_0^2 \left(\frac{gx_{max}}{\sqrt{v_0^4 + g^2 x_{max}^2}} \right)^2} = \frac{v_0^2}{gx_{max}} - \frac{x(v_0^4 + g^2 x_{max}^2)}{v_0^2 gx_{max}^2}$$

$$\frac{dy}{dx} = \frac{v_0^2}{gx_{max}} - \frac{v_0^2 x}{gx_{max}^2} - \frac{gx}{v_0^2}$$

- When $x = x_{max}$, the value of this derivative is negative.

$$\left. \frac{dy}{dx} \right|_{x_{max}} = -\frac{gx_{max}}{v_0^2}$$

- Therefore, the ball has already reached the peak and is on its way down.

2. Solve the equation for maximum angle to determine x :

$$\tan \theta_{max} = \frac{v_0^2}{gx} \Rightarrow x = \frac{v_0^2}{g}$$

- Substitute this value into the equation for y to determine the maximum height.

$$y = y_0 + \frac{v_0^2}{g} - \frac{g \left(\frac{v_0^2}{g} \right)^2}{v_0^2} = y_0 + \frac{v_0^2}{g} - \frac{v_0^2}{g}$$

$$y = y_0$$

Technical Support

For assistance with any PASCO product, contact PASCO at:

Address: PASCO scientific
10101 Foothills Blvd.
Roseville, CA 95747-7100

Phone: 916-786-3800 (worldwide)
800-772-8700 (U.S.)

Fax: (916) 786-7565

Web: www.pasco.com

Email: support@pasco.com

For more information about the Projectile Launcher and the latest revision of this Instruction Manual, visit the PASCO web site and enter ME-6800 or ME-6801 into the Search window.

Limited Warranty For a description of the product warranty, see the PASCO catalog.

Copyright The PASCO scientific 012-05043G *Projectile Launcher Instruction Manual* is copyrighted with all rights reserved. Permission is granted to non-profit educational institutions for reproduction of any part of this manual, providing the reproductions are used only in their laboratories and classrooms, and are not sold for profit. Reproduction under any other circumstances, without the written consent of PASCO scientific, is prohibited.

Trademarks PASCO and PASCO scientific are trademarks or registered trademarks of PASCO scientific, in the United States and/or in other countries. All other brands, products, or service names are or may be trademarks or service marks of, and are used to identify, products or services of, their respective owners. For more information visit www.pasco.com/legal.

